

TNC8F46EC-EM20

TNC Field Replaceable Jack,
SQ 12.7mm(.500inch) 4 Hole Flange With Metal Ring,
Accepts $\phi 0.51\text{mm}(\phi .020\text{inch})$ pin, 18GHz VSWR 1.2

50 Ω

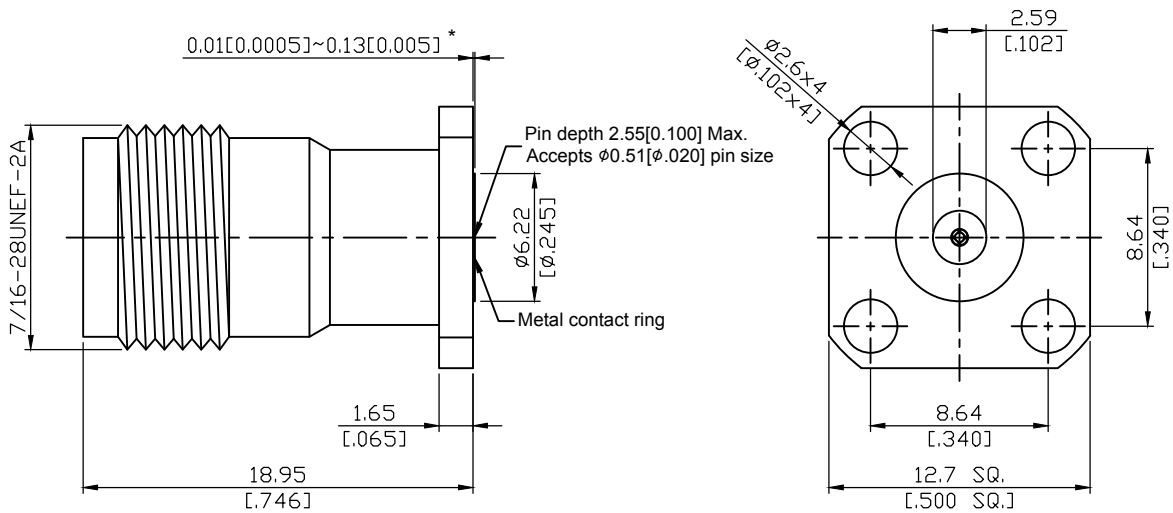

*360° Raised Metal Contact Ring

Parts	Material	Plating (Micro-inch)
Body	Stainless Steel	Passivated
Metal Contact Ring	Stainless Steel	Passivated
Insulator	Teflon	
Contact Pin	Beryllium Copper	Gold 4 Over Nickel-Phosphorus Alloy 80 Over Copper 20

This part number complies with RoHS.

Notice: JYEBAO reserves the right to make modifications deemed appropriate.

TNC	TNC8F46EC-EM20																		
<div data-bbox="167 344 568 394" style="border: 1px solid black; padding: 2px;">Interface</div> <p>MIL-STD-348B</p>																			
<div data-bbox="167 510 568 560" style="border: 1px solid black; padding: 2px;">Electrical Data</div> <table border="0" style="width: 100%;"> <tr> <td style="width: 50%;">Impedance</td> <td style="width: 50%;">50Ω</td> </tr> <tr> <td>Frequency range</td> <td>DC to 18GHz</td> </tr> <tr> <td>VSWR</td> <td>≤ 1.2 (DC to 18GHz)</td> </tr> <tr> <td>Insertion loss</td> <td>≤ 0.1 x √f(GHz) dB</td> </tr> <tr> <td>Insulation resistance</td> <td>≥ 5000MΩ</td> </tr> <tr> <td>Contact resistance inner conductor</td> <td>≤ 1.5mΩ</td> </tr> <tr> <td>Contact resistance outer conductor</td> <td>≤ 1mΩ</td> </tr> <tr> <td>Dielectric withstanding voltage (at sea level)</td> <td>1500 V rms</td> </tr> <tr> <td>Working voltage (at sea level)</td> <td>500 V rms</td> </tr> </table>		Impedance	50Ω	Frequency range	DC to 18GHz	VSWR	≤ 1.2 (DC to 18GHz)	Insertion loss	≤ 0.1 x √f(GHz) dB	Insulation resistance	≥ 5000MΩ	Contact resistance inner conductor	≤ 1.5mΩ	Contact resistance outer conductor	≤ 1mΩ	Dielectric withstanding voltage (at sea level)	1500 V rms	Working voltage (at sea level)	500 V rms
Impedance	50Ω																		
Frequency range	DC to 18GHz																		
VSWR	≤ 1.2 (DC to 18GHz)																		
Insertion loss	≤ 0.1 x √f(GHz) dB																		
Insulation resistance	≥ 5000MΩ																		
Contact resistance inner conductor	≤ 1.5mΩ																		
Contact resistance outer conductor	≤ 1mΩ																		
Dielectric withstanding voltage (at sea level)	1500 V rms																		
Working voltage (at sea level)	500 V rms																		
<div data-bbox="167 1055 568 1104" style="border: 1px solid black; padding: 2px;">Mechanical Data</div> <table border="0" style="width: 100%;"> <tr> <td style="width: 50%;">Recommended coupling nut torque</td> <td style="width: 50%;">4.1 to 6.1 inch lbs</td> </tr> <tr> <td>Coupling proof torque</td> <td>15 inch lbs</td> </tr> <tr> <td>Contact captivation-axial</td> <td>≥ 6.1 lbs</td> </tr> <tr> <td>Durability (mating)</td> <td>≥ 500</td> </tr> </table>		Recommended coupling nut torque	4.1 to 6.1 inch lbs	Coupling proof torque	15 inch lbs	Contact captivation-axial	≥ 6.1 lbs	Durability (mating)	≥ 500										
Recommended coupling nut torque	4.1 to 6.1 inch lbs																		
Coupling proof torque	15 inch lbs																		
Contact captivation-axial	≥ 6.1 lbs																		
Durability (mating)	≥ 500																		
<div data-bbox="167 1411 568 1460" style="border: 1px solid black; padding: 2px;">Environmental Data</div> <table border="0" style="width: 100%;"> <tr> <td style="width: 50%;">Temperature range</td> <td style="width: 50%;">-65°C to +165°C</td> </tr> <tr> <td>Thermal shock</td> <td>MIL-STD-202, Method 107, Condition B</td> </tr> <tr> <td>Moisture resistance</td> <td>MIL-STD-202, Method 106</td> </tr> <tr> <td>Corrosion</td> <td>MIL-STD-202, Method 101, Condition B</td> </tr> <tr> <td>RoHS</td> <td>Compliant</td> </tr> </table>		Temperature range	-65°C to +165°C	Thermal shock	MIL-STD-202, Method 107, Condition B	Moisture resistance	MIL-STD-202, Method 106	Corrosion	MIL-STD-202, Method 101, Condition B	RoHS	Compliant								
Temperature range	-65°C to +165°C																		
Thermal shock	MIL-STD-202, Method 107, Condition B																		
Moisture resistance	MIL-STD-202, Method 106																		
Corrosion	MIL-STD-202, Method 101, Condition B																		
RoHS	Compliant																		
<div data-bbox="167 1762 568 1812" style="border: 1px solid black; padding: 2px;">Accessories</div> <table border="0" style="width: 100%;"> <tr> <td style="width: 50%;">Hermetic seal</td> <td style="width: 50%;">SEAL.02</td> </tr> <tr> <td>Launch pin & Dielectric transition</td> <td>FR020-LAUNCH1; FR020-LAUNCH2</td> </tr> <tr> <td>Tab pin & Dielectric transition</td> <td>FR020-TAB2; FR020-TAB3</td> </tr> <tr> <td>Tab pin</td> <td>FR020-TAB1; FRPIN.02</td> </tr> </table>		Hermetic seal	SEAL.02	Launch pin & Dielectric transition	FR020-LAUNCH1; FR020-LAUNCH2	Tab pin & Dielectric transition	FR020-TAB2; FR020-TAB3	Tab pin	FR020-TAB1; FRPIN.02										
Hermetic seal	SEAL.02																		
Launch pin & Dielectric transition	FR020-LAUNCH1; FR020-LAUNCH2																		
Tab pin & Dielectric transition	FR020-TAB2; FR020-TAB3																		
Tab pin	FR020-TAB1; FRPIN.02																		

Notice: JYEBAO reserves the right to make modifications deemed appropriate.

Recommended Launch Hole Dimensions :

1. Using Hermetic seals

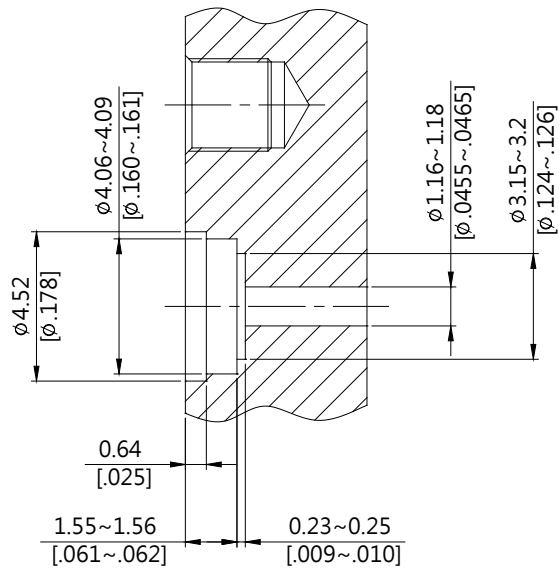

Hermetic seal P/N

SEAL.02

2. Using dielectric with Tab or Launch pin

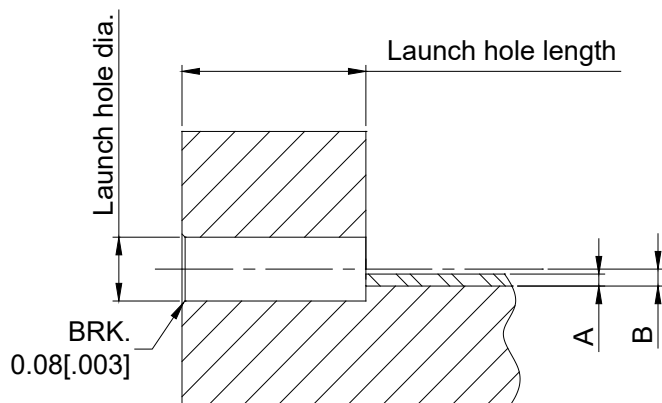

"A" = Substrate thickness

"B" = A + 1/2 Tab or Launch terminal

Dielectric and Tab/Launch pin P/N	Recommended Launch hole dia.	Recommended Launch hole length
FR020-LAUNCH1	ϕ 1.63 (.064)	4.75 (.187)
FR020-LAUNCH2	ϕ 1.63 (.064)	3.18 (.125)
FR020-TAB2	ϕ 1.63 (.064)	4.75 (.187)
FR020-TAB3	ϕ 1.63 (.064)	3.18 (.125)

3. Using Tab pin

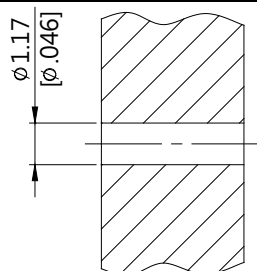

Tab pin P/N

FR020-TAB1

FRPIN.02