

<b>TNC864L-0000/IP67U</b>	<b>TNC Jack SQ 17.5mm 4 Hole Flange</b> With Round Contact ( $\Phi 1.27$ ; L=4.3), PTFE L=6.5; IP67 Unmated; 6GHz VSWR 1.2	<b>50<math>\Omega</math></b>
---------------------------	--	------------------------------

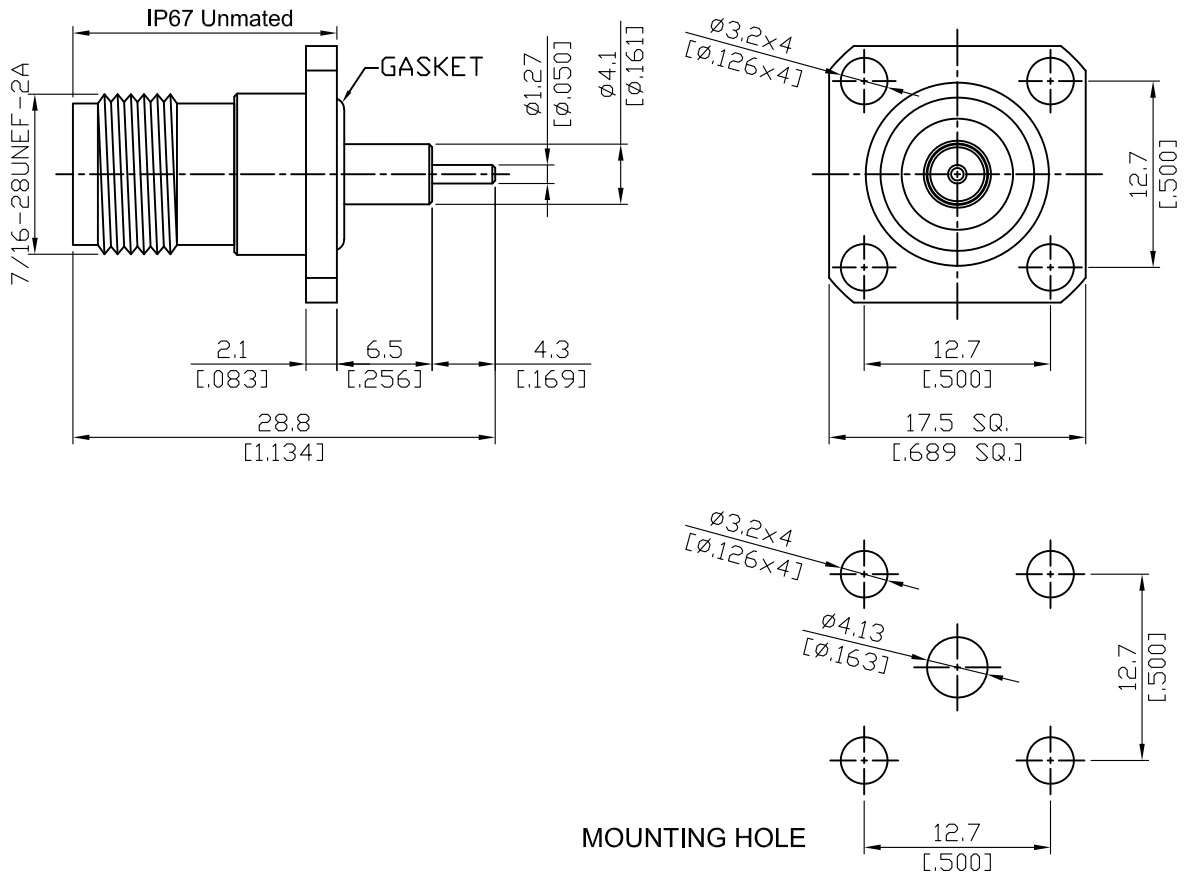

Parts	Material	Plating ( Micro-inch )
Gasket	Silicone	
Contact Pin	Beryllium Copper	Gold 4 Over Nickel-Phosphorus Alloy 80 Over Copper 20
Insulator	Teflon	
Body	Brass	Tin-Zinc-Copper-Alloy 100 Over Copper 50

--	--

This part number complies with RoHS.  
 Notice: JYEBAO reserves the right to make modifications deemed appropriate.

TNC	TNC864L-0000/IP67U																		
<div data-bbox="167 348 561 390" style="border: 1px solid black; padding: 2px;">Interface</div> <p>MIL-STD-348B</p>																			
<div data-bbox="167 510 561 552" style="border: 1px solid black; padding: 2px;">Electrical Data</div> <table border="0" style="width: 100%;"> <tr> <td style="width: 50%;">Impedance</td> <td style="width: 50%;">50Ω</td> </tr> <tr> <td>Frequency range</td> <td>DC to 6GHz</td> </tr> <tr> <td>VSWR</td> <td>≤ 1.2 (DC to 6GHz)</td> </tr> <tr> <td>Insertion loss</td> <td>≤ 0.1 x √f(GHz) dB</td> </tr> <tr> <td>Insulation resistance</td> <td>≥ 5000MΩ</td> </tr> <tr> <td>Contact resistance inner conductor</td> <td>≤ 1.5mΩ</td> </tr> <tr> <td>Contact resistance outer conductor</td> <td>≤ 1mΩ</td> </tr> <tr> <td>Dielectric withstanding voltage (at sea level)</td> <td>1500 V rms</td> </tr> <tr> <td>Working voltage (at sea level)</td> <td>500 V rms</td> </tr> </table>		Impedance	50Ω	Frequency range	DC to 6GHz	VSWR	≤ 1.2 (DC to 6GHz)	Insertion loss	≤ 0.1 x √f(GHz) dB	Insulation resistance	≥ 5000MΩ	Contact resistance inner conductor	≤ 1.5mΩ	Contact resistance outer conductor	≤ 1mΩ	Dielectric withstanding voltage (at sea level)	1500 V rms	Working voltage (at sea level)	500 V rms
Impedance	50Ω																		
Frequency range	DC to 6GHz																		
VSWR	≤ 1.2 (DC to 6GHz)																		
Insertion loss	≤ 0.1 x √f(GHz) dB																		
Insulation resistance	≥ 5000MΩ																		
Contact resistance inner conductor	≤ 1.5mΩ																		
Contact resistance outer conductor	≤ 1mΩ																		
Dielectric withstanding voltage (at sea level)	1500 V rms																		
Working voltage (at sea level)	500 V rms																		
<div data-bbox="167 1056 561 1098" style="border: 1px solid black; padding: 2px;">Mechanical Data</div> <table border="0" style="width: 100%;"> <tr> <td style="width: 50%;">Recommended coupling nut torque</td> <td style="width: 50%;">4.1 to 6.1 inch lbs</td> </tr> <tr> <td>Coupling proof torque</td> <td>15 inch lbs</td> </tr> <tr> <td>Contact captivation-axial</td> <td>≥ 6.1 lbs</td> </tr> <tr> <td>Durability (mating)</td> <td>≥ 500</td> </tr> </table>		Recommended coupling nut torque	4.1 to 6.1 inch lbs	Coupling proof torque	15 inch lbs	Contact captivation-axial	≥ 6.1 lbs	Durability (mating)	≥ 500										
Recommended coupling nut torque	4.1 to 6.1 inch lbs																		
Coupling proof torque	15 inch lbs																		
Contact captivation-axial	≥ 6.1 lbs																		
Durability (mating)	≥ 500																		
<div data-bbox="167 1407 561 1449" style="border: 1px solid black; padding: 2px;">Environmental Data</div> <table border="0" style="width: 100%;"> <tr> <td style="width: 50%;">Temperature range</td> <td style="width: 50%;">-65°C to +165°C</td> </tr> <tr> <td>Thermal shock</td> <td>MIL-STD-202, Method 107, Condition B</td> </tr> <tr> <td>Moisture resistance</td> <td>MIL-STD-202, Method 106</td> </tr> <tr> <td>Corrosion</td> <td>MIL-STD-202, Method 101, Condition B</td> </tr> <tr> <td>RoHS</td> <td>Compliant</td> </tr> </table>		Temperature range	-65°C to +165°C	Thermal shock	MIL-STD-202, Method 107, Condition B	Moisture resistance	MIL-STD-202, Method 106	Corrosion	MIL-STD-202, Method 101, Condition B	RoHS	Compliant								
Temperature range	-65°C to +165°C																		
Thermal shock	MIL-STD-202, Method 107, Condition B																		
Moisture resistance	MIL-STD-202, Method 106																		
Corrosion	MIL-STD-202, Method 101, Condition B																		
RoHS	Compliant																		
<div data-bbox="167 1757 561 1799" style="border: 1px solid black; padding: 2px;">Tooling</div>																			

# TNC864L-0000/IP67U

SoftPlot Measurement Presentation  
VSWR S11

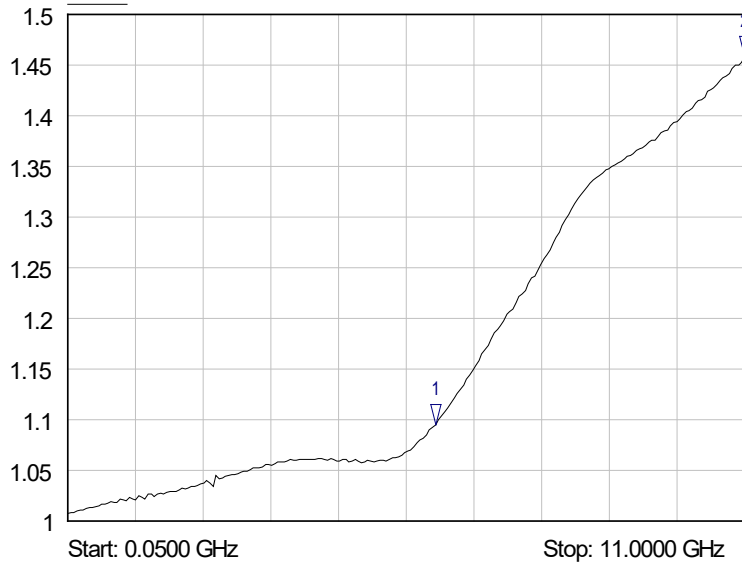

- 1 S11  
6.0000 GHz  
1.10 VSWR
- 2 S11  
11.0000 GHz  
1.46 VSWR