

SMP3500S1-FD38

SMP Plug Full Detent Screw In Shroud With Round Contact (Φ0.38;L=1.45); 18GHz VSWR 1.2 50Ω

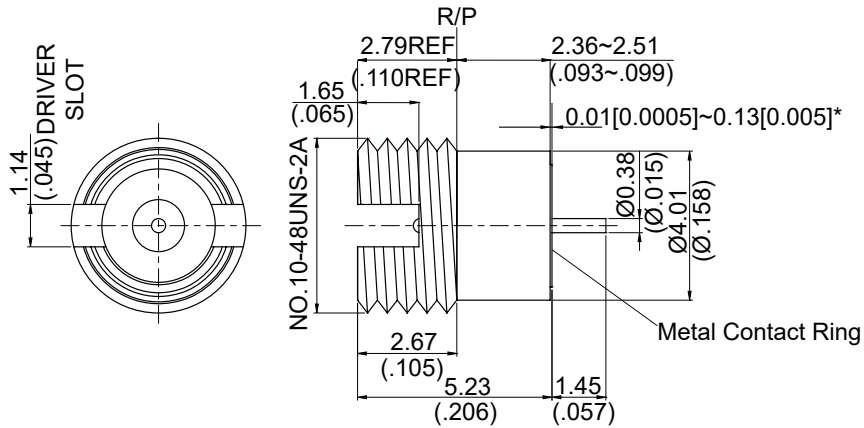

MOUNTING HOLE:

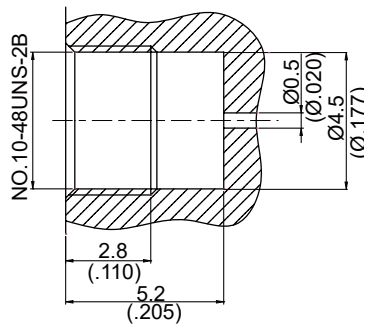

* 360° Raised Metal Contact Ring

Parts	Material	Plating (Micro-inch)
Insulator	Teflon	
Metal Contact Ring	Beryllium Copper	Gold 4 Over Nickel-Phosphorus Alloy 80 Over Copper 20
Contact Pin	Beryllium Copper	Gold 4 Over Nickel-Phosphorus Alloy 80 Over Copper 20
Body	Beryllium Copper	Gold 4 Over Nickel-Phosphorus Alloy 80 Over Copper 20

This part number complies with RoHS.

Notice: JYEBAO reserves the right to make modifications deemed appropriate.

SMP	SMP3500S1-FD38																																																					
<div style="border: 1px solid black; padding: 2px; margin-bottom: 5px;">Interface</div> MIL-STD-348B																																																						
<div style="border: 1px solid black; padding: 2px; margin-bottom: 5px;">Electrical Data</div> <table style="width: 100%; border-collapse: collapse;"> <tr> <td style="width: 50%;">Impedance</td> <td colspan="4">50Ω</td> </tr> <tr> <td>Frequency range</td> <td colspan="4">DC to 18GHz</td> </tr> <tr> <td>VSWR</td> <td colspan="4">≤ 1.2 (DC to 18GHz)</td> </tr> <tr> <td>Insertion loss</td> <td colspan="4">≤ .06 x √f(GHz) dB</td> </tr> <tr> <td>Insulation resistance</td> <td colspan="4">≥ 5000 MΩ</td> </tr> <tr> <td>Contact resistance inner conductor</td> <td colspan="4">≤ 6mΩ</td> </tr> <tr> <td>Contact resistance outer conductor</td> <td colspan="4">≤ 2mΩ</td> </tr> <tr> <td>Dielectric withstanding voltage (at sea level)</td> <td colspan="4">500</td> </tr> <tr> <td>Working Voltage (at sea level)</td> <td colspan="4">335</td> </tr> <tr> <td>RF-Leakage</td> <td colspan="4">≥ 80dB (3GHz); ≥ 65dB (3~26.5GHz)</td> </tr> </table>					Impedance	50Ω				Frequency range	DC to 18GHz				VSWR	≤ 1.2 (DC to 18GHz)				Insertion loss	≤ .06 x √f(GHz) dB				Insulation resistance	≥ 5000 MΩ				Contact resistance inner conductor	≤ 6mΩ				Contact resistance outer conductor	≤ 2mΩ				Dielectric withstanding voltage (at sea level)	500				Working Voltage (at sea level)	335				RF-Leakage	≥ 80dB (3GHz); ≥ 65dB (3~26.5GHz)			
Impedance	50Ω																																																					
Frequency range	DC to 18GHz																																																					
VSWR	≤ 1.2 (DC to 18GHz)																																																					
Insertion loss	≤ .06 x √f(GHz) dB																																																					
Insulation resistance	≥ 5000 MΩ																																																					
Contact resistance inner conductor	≤ 6mΩ																																																					
Contact resistance outer conductor	≤ 2mΩ																																																					
Dielectric withstanding voltage (at sea level)	500																																																					
Working Voltage (at sea level)	335																																																					
RF-Leakage	≥ 80dB (3GHz); ≥ 65dB (3~26.5GHz)																																																					
<div style="border: 1px solid black; padding: 2px; margin-bottom: 5px;">Mechanical Data</div> <table style="width: 100%; border-collapse: collapse;"> <thead> <tr> <th style="width: 50%;"></th> <th style="width: 12.5%;">Full Detent</th> <th style="width: 12.5%;">Limited Detent</th> <th style="width: 12.5%;">Smooth bore & catchers mit</th> <th style="width: 12.5%;"></th> </tr> </thead> <tbody> <tr> <td>Engagement force</td> <td>≤ 15</td> <td>≤ 10</td> <td>≤ 2</td> <td>lbs</td> </tr> <tr> <td>Disengagement force</td> <td>≥ 5</td> <td>≥ 2</td> <td>≥ 0.5</td> <td>lbs</td> </tr> <tr> <td>Durability (mating)</td> <td>≥ 100</td> <td>≥ 500</td> <td>≥ 1000</td> <td></td> </tr> <tr> <td>Axial misalignment</td> <td colspan="4" style="text-align: center;">+ 0.00 / -0.25 (+.000 / -.010)</td> </tr> <tr> <td>Radial misalignment</td> <td colspan="4" style="text-align: center;">±0.25 (0.010)</td> </tr> </tbody> </table>						Full Detent	Limited Detent	Smooth bore & catchers mit		Engagement force	≤ 15	≤ 10	≤ 2	lbs	Disengagement force	≥ 5	≥ 2	≥ 0.5	lbs	Durability (mating)	≥ 100	≥ 500	≥ 1000		Axial misalignment	+ 0.00 / -0.25 (+.000 / -.010)				Radial misalignment	±0.25 (0.010)																							
	Full Detent	Limited Detent	Smooth bore & catchers mit																																																			
Engagement force	≤ 15	≤ 10	≤ 2	lbs																																																		
Disengagement force	≥ 5	≥ 2	≥ 0.5	lbs																																																		
Durability (mating)	≥ 100	≥ 500	≥ 1000																																																			
Axial misalignment	+ 0.00 / -0.25 (+.000 / -.010)																																																					
Radial misalignment	±0.25 (0.010)																																																					
<div style="border: 1px solid black; padding: 2px; margin-bottom: 5px;">Environmental Data</div> <table style="width: 100%; border-collapse: collapse;"> <tr> <td style="width: 50%;">Temperature range</td> <td colspan="4">-65°C to +165°C</td> </tr> <tr> <td>Thermal shock</td> <td colspan="4">MIL-STD-202, Method 107, Condition B</td> </tr> <tr> <td>Moisture resistance</td> <td colspan="4">MIL-STD-202, Method 106</td> </tr> <tr> <td>Corrosion</td> <td colspan="4">MIL-STD-202, Method 101, Condition B</td> </tr> <tr> <td>RoHS</td> <td colspan="4">Compliant</td> </tr> </table>					Temperature range	-65°C to +165°C				Thermal shock	MIL-STD-202, Method 107, Condition B				Moisture resistance	MIL-STD-202, Method 106				Corrosion	MIL-STD-202, Method 101, Condition B				RoHS	Compliant																												
Temperature range	-65°C to +165°C																																																					
Thermal shock	MIL-STD-202, Method 107, Condition B																																																					
Moisture resistance	MIL-STD-202, Method 106																																																					
Corrosion	MIL-STD-202, Method 101, Condition B																																																					
RoHS	Compliant																																																					
<div style="border: 1px solid black; padding: 2px; margin-bottom: 5px;">Tooling</div>																																																						

SMP3500S1-FD38

SoftPlot Measurement Presentation
VSWR S22

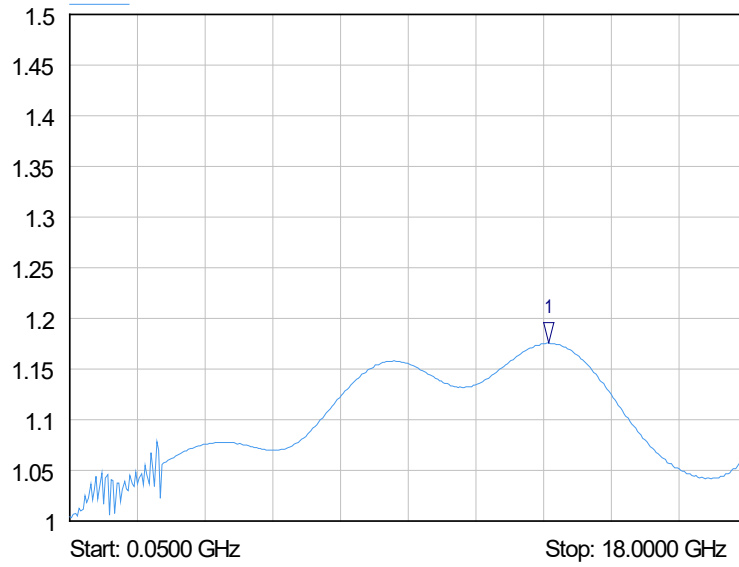

1 S22
▽ 12.7500 GHz
1.18 VSWR