

SMP34TM-FD00

**SMP Full Detent Plug PCB Mount
With Round Contact (Φ0.8); 18Ghz VSWR 1.2**

50Ω

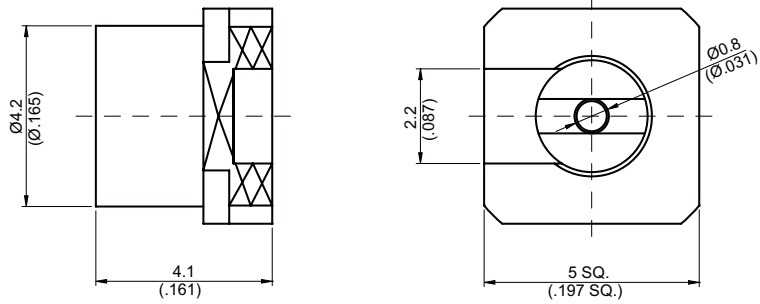

PCB LAYOUT

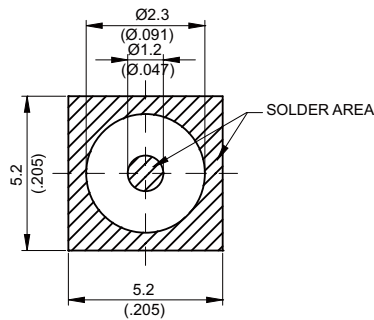

Parts	Material	Plating (Micro-inch)
Body	Brass	Gold 4 Over Nickel Phosphorous Alloy 80 Over Copper 20
Insulator	Teflon	
Contact Pin	Brass	Gold 4 Over Nickel Phosphorous Alloy 80 Over Copper 20

This part number complies with RoHS.

Notice: JYEBAO reserves the right to make modifications deemed appropriate.

SMP	SMP34TM-FD00																																	
<div style="border: 1px solid black; padding: 2px; margin-bottom: 5px;">Interface</div> MIL-STD-348B																																		
<div style="border: 1px solid black; padding: 2px; margin-bottom: 5px;">Electrical Data</div> Impedance 50Ω Frequency range DC to 18GHz VSWR ≤ 1.2 (DC to 18GHz) Insertion loss $\leq .06 \times \sqrt{f(\text{GHz})}$ dB Insulation resistance $\geq 5000 \text{ M}\Omega$ Contact resistance inner conductor $\leq 6\text{m}\Omega$ Contact resistance outer conductor $\leq 2\text{m}\Omega$ Dielectric withstanding voltage (at sea level) 500 Working Voltage (at sea level) 335 RF-Leakage $\geq 80\text{dB}$ (3GHz); $\geq 65\text{dB}$ (3~26.5GHz)																																		
<div style="border: 1px solid black; padding: 2px; margin-bottom: 5px;">Mechanical Data</div> <table border="1" style="width: 100%; border-collapse: collapse;"> <thead> <tr> <th></th> <th style="text-align: center;">Full Detent</th> <th style="text-align: center;">Limited Detent</th> <th style="text-align: center;">Smooth bore & catchers mit</th> <th></th> </tr> </thead> <tbody> <tr> <td>Engagement force</td> <td style="text-align: center;">≤ 15</td> <td style="text-align: center;">≤ 10</td> <td style="text-align: center;">≤ 2</td> <td style="text-align: center;">lbs</td> </tr> <tr> <td>Disengagement force</td> <td style="text-align: center;">≥ 5</td> <td style="text-align: center;">≥ 2</td> <td style="text-align: center;">≥ 0.5</td> <td style="text-align: center;">lbs</td> </tr> <tr> <td>Durability (mating)</td> <td style="text-align: center;">≥ 100</td> <td style="text-align: center;">≥ 500</td> <td style="text-align: center;">≥ 1000</td> <td></td> </tr> <tr> <td>Axial misalignment</td> <td colspan="4" style="text-align: center;">$+ 0.00 / -0.25 (+.000 / -.010)$</td> </tr> <tr> <td>Radial misalignment</td> <td colspan="4" style="text-align: center;">$\pm 0.25 (0.010), \text{min}$</td> </tr> </tbody> </table>						Full Detent	Limited Detent	Smooth bore & catchers mit		Engagement force	≤ 15	≤ 10	≤ 2	lbs	Disengagement force	≥ 5	≥ 2	≥ 0.5	lbs	Durability (mating)	≥ 100	≥ 500	≥ 1000		Axial misalignment	$+ 0.00 / -0.25 (+.000 / -.010)$				Radial misalignment	$\pm 0.25 (0.010), \text{min}$			
	Full Detent	Limited Detent	Smooth bore & catchers mit																															
Engagement force	≤ 15	≤ 10	≤ 2	lbs																														
Disengagement force	≥ 5	≥ 2	≥ 0.5	lbs																														
Durability (mating)	≥ 100	≥ 500	≥ 1000																															
Axial misalignment	$+ 0.00 / -0.25 (+.000 / -.010)$																																	
Radial misalignment	$\pm 0.25 (0.010), \text{min}$																																	
<div style="border: 1px solid black; padding: 2px; margin-bottom: 5px;">Environmental Data</div> Temperature range -65°C to +165°C Thermal shock MIL-STD-202, Method 107, Condition B Moisture resistance MIL-STD-202, Method 106 Corrosion MIL-STD-202, Method 101, Condition B RoHS Compliant																																		
<div style="border: 1px solid black; padding: 2px; margin-bottom: 5px;">Tooling</div>																																		

SMP34TM-FD00

S11

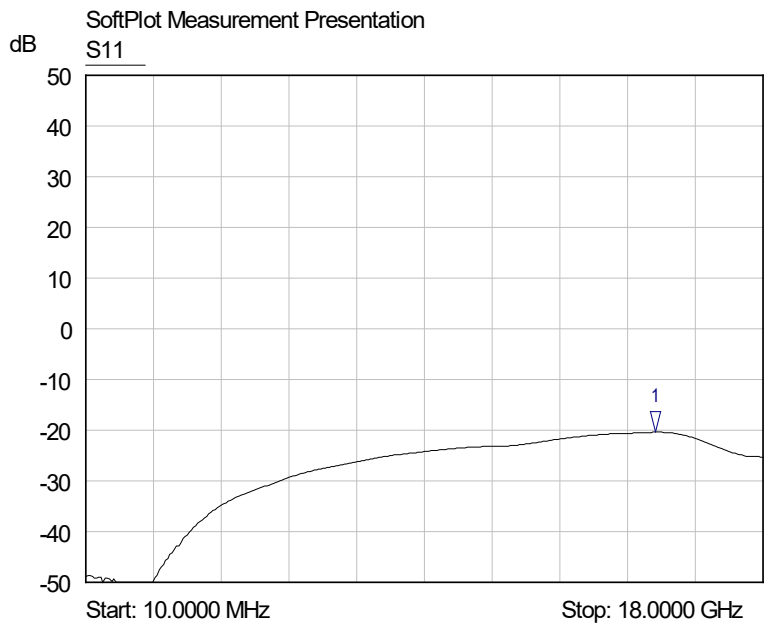

1 S11
▽ 15.1354 GHz
-20.39 dB