

SMC8400A-9000

SMC Jack PCB Mount Right Angle
With Round Contact (Φ0.95); 3GHz VSWR 1.2 **50Ω**

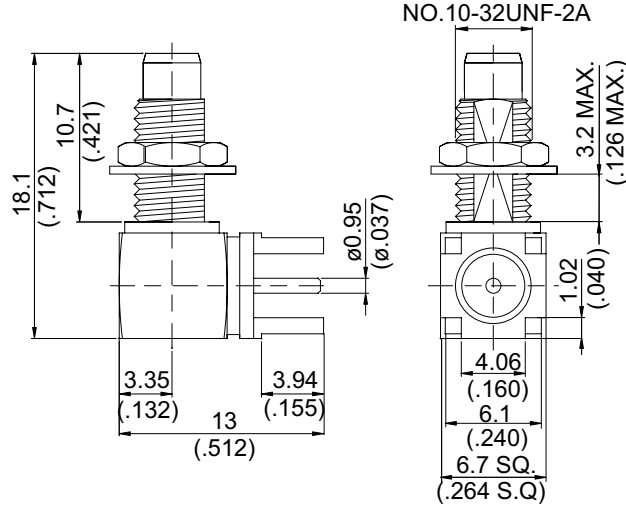

MOUNTING HOLE :

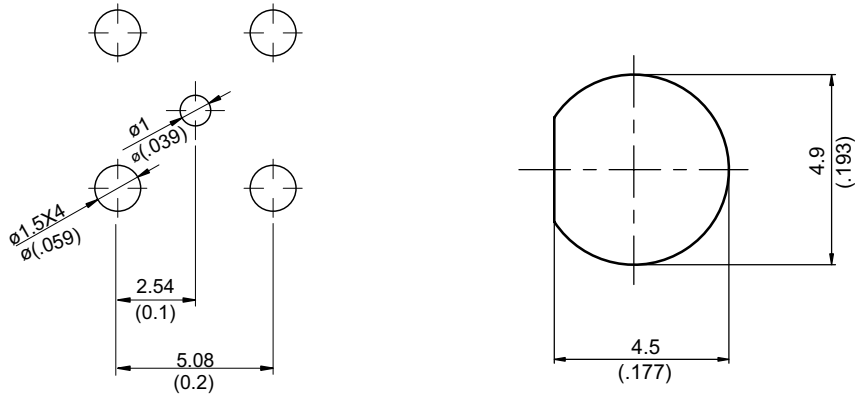

Parts	Material	Plating (Micro-inch)
Hex Nut	Brass	Gold 4 Over Nickel-Phosphorus Alloy 80 Over Copper 20
Lock Wassher	Brass	Gold 4 Over Nickel-Phosphorus Alloy 80 Over Copper 20
Cover	Brass	Gold 4 Over Nickel-Phosphorus Alloy 80 Over Copper 20
Part	Brass	Gold 4 Over Nickel-Phosphorus Alloy 80 Over Copper 20
Contact Pin	Brass	Gold 4 Over Nickel-Phosphorus Alloy 80 Over Copper 20
Insulator	Teflon	
Housing	Brass	Gold 4 Over Nickel-Phosphorus Alloy 80 Over Copper 20
Body	Brass	Gold 4 Over Nickel-Phosphorus Alloy 80 Over Copper 20

Weight: 3.51 g

This part number complies with RoHS.

Notice: JYEBAO reserves the right to make modifications deemed appropriate.

SMC	SMC8400A-9000																				
<div style="border: 1px solid black; padding: 2px; margin-bottom: 5px;">Interface</div> MIL-STD-348B																					
<div style="border: 1px solid black; padding: 2px; margin-bottom: 5px;">Electrical Data</div> <table style="width: 100%; border-collapse: collapse;"> <tr> <td style="width: 50%;">Impedance</td> <td style="width: 50%;">50Ω</td> </tr> <tr> <td>Frequency range</td> <td>DC to 3GHz</td> </tr> <tr> <td>VSWR</td> <td>≦ 1.2 (DC to 3GHz)</td> </tr> <tr> <td>Insertion loss</td> <td>≦ 0.1 x √f(GHz)dB</td> </tr> <tr> <td>Insulation resistance</td> <td>≧ 10000MΩ</td> </tr> <tr> <td>Contact resistance inner conductor</td> <td>≦ 5mΩ</td> </tr> <tr> <td>Contact resistance outer conductor</td> <td>≦ 2.5mΩ</td> </tr> <tr> <td>Dielectric withstanding voltage (at sea level)</td> <td>750 V rms</td> </tr> <tr> <td>Working voltage (at sea level)</td> <td>250 V rms</td> </tr> <tr> <td>RF leakage</td> <td>≧ 90dB to 1GHz</td> </tr> </table>		Impedance	50Ω	Frequency range	DC to 3GHz	VSWR	≦ 1.2 (DC to 3GHz)	Insertion loss	≦ 0.1 x √f(GHz)dB	Insulation resistance	≧ 10000MΩ	Contact resistance inner conductor	≦ 5mΩ	Contact resistance outer conductor	≦ 2.5mΩ	Dielectric withstanding voltage (at sea level)	750 V rms	Working voltage (at sea level)	250 V rms	RF leakage	≧ 90dB to 1GHz
Impedance	50Ω																				
Frequency range	DC to 3GHz																				
VSWR	≦ 1.2 (DC to 3GHz)																				
Insertion loss	≦ 0.1 x √f(GHz)dB																				
Insulation resistance	≧ 10000MΩ																				
Contact resistance inner conductor	≦ 5mΩ																				
Contact resistance outer conductor	≦ 2.5mΩ																				
Dielectric withstanding voltage (at sea level)	750 V rms																				
Working voltage (at sea level)	250 V rms																				
RF leakage	≧ 90dB to 1GHz																				
<div style="border: 1px solid black; padding: 2px; margin-bottom: 5px;">Mechanical Data</div> <table style="width: 100%; border-collapse: collapse;"> <tr> <td style="width: 50%;">Recommended coupling nut torque</td> <td style="width: 50%;">2.2 to 3.1 inch lbs</td> </tr> <tr> <td>Coupling proof torque</td> <td>6.2 inch lbs</td> </tr> <tr> <td>Contact captivation-axial</td> <td>≧ 2.25 lbs</td> </tr> <tr> <td>Durability (mating)</td> <td>≧ 500</td> </tr> </table>		Recommended coupling nut torque	2.2 to 3.1 inch lbs	Coupling proof torque	6.2 inch lbs	Contact captivation-axial	≧ 2.25 lbs	Durability (mating)	≧ 500												
Recommended coupling nut torque	2.2 to 3.1 inch lbs																				
Coupling proof torque	6.2 inch lbs																				
Contact captivation-axial	≧ 2.25 lbs																				
Durability (mating)	≧ 500																				
<div style="border: 1px solid black; padding: 2px; margin-bottom: 5px;">Environmental Data</div> <table style="width: 100%; border-collapse: collapse;"> <tr> <td style="width: 50%;">Temperature range</td> <td style="width: 50%;">-65°C to +165°C</td> </tr> <tr> <td>Thermal shock</td> <td>MIL-STD-202, Method 107, Condition B</td> </tr> <tr> <td>Moisture resistance</td> <td>MIL-STD-202, Method 106</td> </tr> <tr> <td>Corrosion</td> <td>MIL-STD-202, Method 101, Condition B</td> </tr> <tr> <td>RoHS</td> <td>Compliant</td> </tr> </table>		Temperature range	-65°C to +165°C	Thermal shock	MIL-STD-202, Method 107, Condition B	Moisture resistance	MIL-STD-202, Method 106	Corrosion	MIL-STD-202, Method 101, Condition B	RoHS	Compliant										
Temperature range	-65°C to +165°C																				
Thermal shock	MIL-STD-202, Method 107, Condition B																				
Moisture resistance	MIL-STD-202, Method 106																				
Corrosion	MIL-STD-202, Method 101, Condition B																				
RoHS	Compliant																				
<div style="border: 1px solid black; padding: 2px; margin-bottom: 5px;">Tooling</div>																					

Notice: JYEBAO reserves the right to make modifications deemed appropriate.

SMC8400A-9000

S11

