

SMB8400P-0000

SMB Jack PCB Edge Mount
With Round Contact (Φ0.5); 4GHz VSWR 1.1 **50Ω**

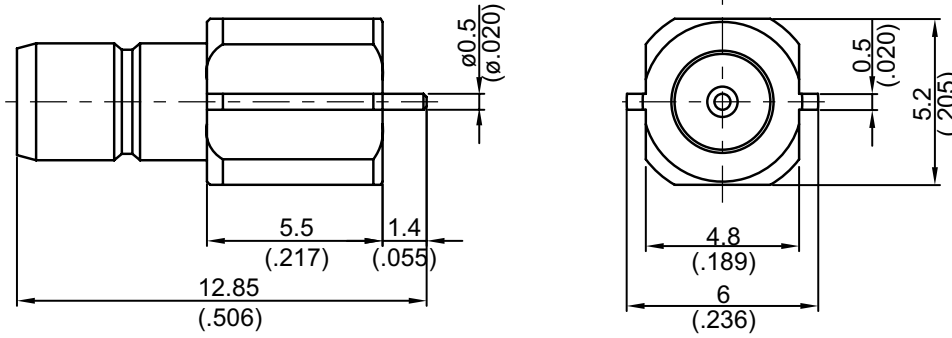

MOUNTING HOLE :

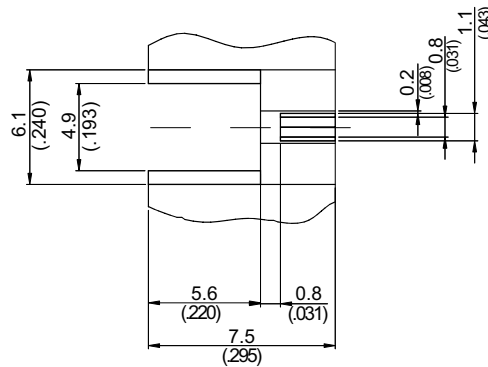

Parts	Material	Plating (Micro-inch)
Contact Pin	Brass	Gold 4 Over Nickel-Phosphorus Alloy 80 Over Copper 20
Insulator	Teflon	
Body	Brass	Gold 4 Over Nickel-Phosphorus Alloy 80 Over Copper 20

Weight: 1.14 g

This part number complies with RoHS.

Notice: JYEBAO reserves the right to make modifications deemed appropriate.

SMB	SMB8400P-0000																		
<div data-bbox="167 344 568 389" style="border: 1px solid black; padding: 2px;">Interface</div> <p>MIL-STD-348B Mechanically compatible with SMS</p>																			
<div data-bbox="167 512 568 557" style="border: 1px solid black; padding: 2px;">Electrical Data</div> <table border="0" style="width: 100%;"> <tr> <td style="width: 50%;">Impedance</td> <td style="width: 50%;">50Ω</td> </tr> <tr> <td>Frequency range</td> <td>DC to 4GHz</td> </tr> <tr> <td>VSWR</td> <td>≤ 1.1 (DC to 4GHz)</td> </tr> <tr> <td>Insertion loss</td> <td>≤ 0.1 x √f(GHz) dB</td> </tr> <tr> <td>Insulation resistance</td> <td>≥ 10000MΩ</td> </tr> <tr> <td>Contact resistance inner conductor</td> <td>≤ 5mΩ</td> </tr> <tr> <td>Contact resistance outer conductor</td> <td>≤ 2.5mΩ</td> </tr> <tr> <td>Dielectric withstanding voltage (at sea level)</td> <td>1000 V rms</td> </tr> <tr> <td>Working Voltage (at sea level)</td> <td>335 V rms</td> </tr> </table>		Impedance	50Ω	Frequency range	DC to 4GHz	VSWR	≤ 1.1 (DC to 4GHz)	Insertion loss	≤ 0.1 x √f(GHz) dB	Insulation resistance	≥ 10000MΩ	Contact resistance inner conductor	≤ 5mΩ	Contact resistance outer conductor	≤ 2.5mΩ	Dielectric withstanding voltage (at sea level)	1000 V rms	Working Voltage (at sea level)	335 V rms
Impedance	50Ω																		
Frequency range	DC to 4GHz																		
VSWR	≤ 1.1 (DC to 4GHz)																		
Insertion loss	≤ 0.1 x √f(GHz) dB																		
Insulation resistance	≥ 10000MΩ																		
Contact resistance inner conductor	≤ 5mΩ																		
Contact resistance outer conductor	≤ 2.5mΩ																		
Dielectric withstanding voltage (at sea level)	1000 V rms																		
Working Voltage (at sea level)	335 V rms																		
<div data-bbox="167 1099 568 1144" style="border: 1px solid black; padding: 2px;">Mechanical Data</div> <table border="0" style="width: 100%;"> <tr> <td style="width: 50%;">Disengagement force</td> <td style="width: 50%;">1.8 to 14.2 lbs</td> </tr> <tr> <td>Engagement force</td> <td>1.8 to 14.2 lbs</td> </tr> <tr> <td>Contact captivation-axial</td> <td>≥ 4 lbs</td> </tr> <tr> <td>Durability (mating)</td> <td>≥ 500</td> </tr> </table>		Disengagement force	1.8 to 14.2 lbs	Engagement force	1.8 to 14.2 lbs	Contact captivation-axial	≥ 4 lbs	Durability (mating)	≥ 500										
Disengagement force	1.8 to 14.2 lbs																		
Engagement force	1.8 to 14.2 lbs																		
Contact captivation-axial	≥ 4 lbs																		
Durability (mating)	≥ 500																		
<div data-bbox="167 1456 568 1500" style="border: 1px solid black; padding: 2px;">Environmental Data</div> <table border="0" style="width: 100%;"> <tr> <td style="width: 50%;">Temperature range</td> <td style="width: 50%;">-65°C to +165°C</td> </tr> <tr> <td>Thermal shock</td> <td>MIL-STD-202, Method 107, Condition B</td> </tr> <tr> <td>Moisture resistance</td> <td>MIL-STD-202, Method 106</td> </tr> <tr> <td>Corrosion</td> <td>MIL-STD-202, Method 101, Condition B</td> </tr> <tr> <td>RoHS</td> <td>Compliant</td> </tr> </table>		Temperature range	-65°C to +165°C	Thermal shock	MIL-STD-202, Method 107, Condition B	Moisture resistance	MIL-STD-202, Method 106	Corrosion	MIL-STD-202, Method 101, Condition B	RoHS	Compliant								
Temperature range	-65°C to +165°C																		
Thermal shock	MIL-STD-202, Method 107, Condition B																		
Moisture resistance	MIL-STD-202, Method 106																		
Corrosion	MIL-STD-202, Method 101, Condition B																		
RoHS	Compliant																		
<div data-bbox="167 1812 568 1856" style="border: 1px solid black; padding: 2px;">Tooling</div>																			

Notice: JYEBAO reserves the right to make modifications deemed appropriate.

SMB8400P-0000

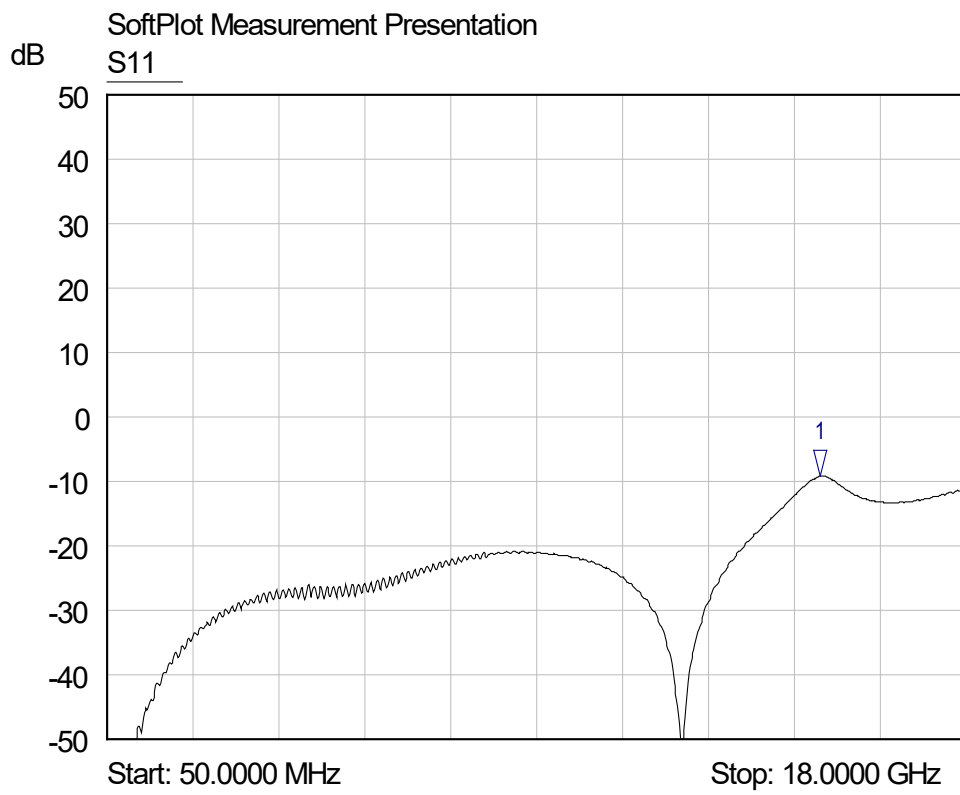

Mkr	Trace	X-Axis	Value	Notes
1 ▽	S11	14.9451 GHz	-9.19 dB	