

SMB3400-9075

**SMB Plug PCB Mount Right Angle
With Round Contact (Φ0.95); 1GHz VSWR 1.2 75Ω**

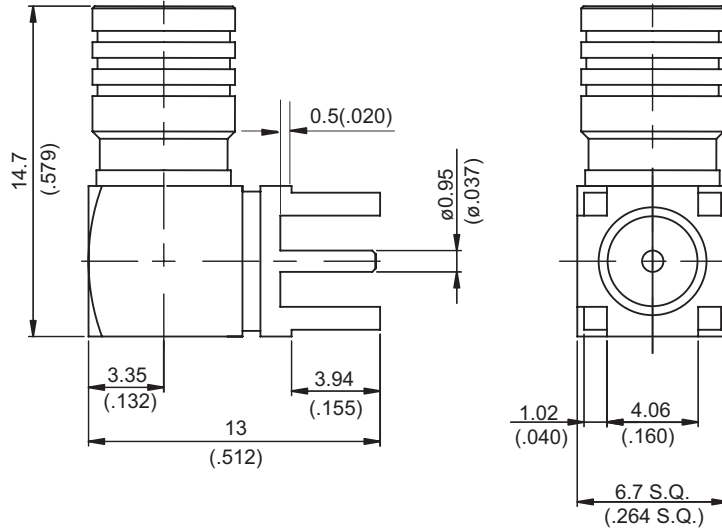

MOUNTING HOLE :

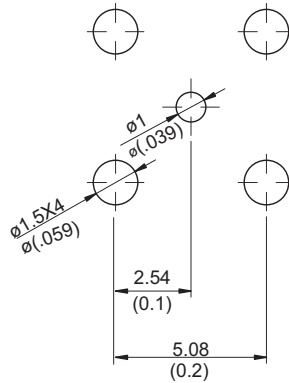

NOTE: 75Ω MINI-SMB INTERFACE

Parts	Material	Plating (Micro-inch)
Cover	Brass	Gold 4 Over Nickel-Phosphorus Alloy 80 Over Copper 20
Retainer Ring	Beryllium Copper	Tin-Zinc-Copper-Alloy 100 Over Copper 50
Part	Brass	Gold 4 Over Nickel-Phosphorus Alloy 80 Over Copper 20
Contact Pin	Beryllium Copper	Gold 4 Over Nickel-Phosphorus Alloy 80 Over Copper 20
Insulator	Teflon	
Body	Brass	Gold 4 Over Nickel-Phosphorus Alloy 80 Over Copper 20
Housing	Brass	Gold 4 Over Nickel-Phosphorus Alloy 80 Over Copper 20
Coupling Nut	Brass	Gold 4 Over Nickel-Phosphorus Alloy 80 Over Copper 20

Weight: 4.06 g

This part number complies with RoHS.

Notice: JYEBAO reserves the right to make modifications deemed appropriate.

SMB	SMB3400-9075																				
<table border="0"> <tr> <td colspan="2" data-bbox="167 347 569 392">Electrical Data</td> </tr> <tr> <td data-bbox="167 403 829 436">Impedance</td> <td data-bbox="853 403 1133 436">75Ω</td> </tr> <tr> <td data-bbox="167 448 829 481">Frequency range</td> <td data-bbox="853 448 1133 481">DC to 1GHz</td> </tr> <tr> <td data-bbox="167 492 829 526">VSWR</td> <td data-bbox="853 492 1133 526">≤ 1.2 (DC to 1GHz)</td> </tr> <tr> <td data-bbox="167 537 829 571">Insertion loss</td> <td data-bbox="853 537 1133 571">≤ 0.1 x √f(GHz)dB</td> </tr> <tr> <td data-bbox="167 582 829 616">Insulation resistance</td> <td data-bbox="853 582 1133 616">≥ 10000MΩ</td> </tr> <tr> <td data-bbox="167 627 829 660">Contact resistance inner conductor</td> <td data-bbox="853 627 1133 660">≤ 5mΩ</td> </tr> <tr> <td data-bbox="167 672 829 705">Contact resistance outer conductor</td> <td data-bbox="853 672 1133 705">≤ 2.5mΩ</td> </tr> <tr> <td data-bbox="167 716 829 750">Dielectric withstanding voltage (at sea level)</td> <td data-bbox="853 716 1133 750">750 V rms</td> </tr> <tr> <td data-bbox="167 761 829 795">Working voltage (at sea level)</td> <td data-bbox="853 761 1133 795">250 V rms</td> </tr> </table>		Electrical Data		Impedance	75Ω	Frequency range	DC to 1GHz	VSWR	≤ 1.2 (DC to 1GHz)	Insertion loss	≤ 0.1 x √f(GHz)dB	Insulation resistance	≥ 10000MΩ	Contact resistance inner conductor	≤ 5mΩ	Contact resistance outer conductor	≤ 2.5mΩ	Dielectric withstanding voltage (at sea level)	750 V rms	Working voltage (at sea level)	250 V rms
Electrical Data																					
Impedance	75Ω																				
Frequency range	DC to 1GHz																				
VSWR	≤ 1.2 (DC to 1GHz)																				
Insertion loss	≤ 0.1 x √f(GHz)dB																				
Insulation resistance	≥ 10000MΩ																				
Contact resistance inner conductor	≤ 5mΩ																				
Contact resistance outer conductor	≤ 2.5mΩ																				
Dielectric withstanding voltage (at sea level)	750 V rms																				
Working voltage (at sea level)	250 V rms																				
<table border="0"> <tr> <td colspan="2" data-bbox="167 940 569 985">Mechanical Data</td> </tr> <tr> <td data-bbox="167 996 829 1030">Disengagement force</td> <td data-bbox="853 996 1133 1030">1.8 to 14.2 lbs</td> </tr> <tr> <td data-bbox="167 1041 829 1075">Engagement force</td> <td data-bbox="853 1041 1133 1075">1.8 to 14.2 lbs</td> </tr> <tr> <td data-bbox="167 1086 829 1120">Contact captivation-axial</td> <td data-bbox="853 1086 1133 1120">≥ 4 lbs</td> </tr> <tr> <td data-bbox="167 1131 829 1164">Durability (mating)</td> <td data-bbox="853 1131 1133 1164">≥ 500</td> </tr> </table>		Mechanical Data		Disengagement force	1.8 to 14.2 lbs	Engagement force	1.8 to 14.2 lbs	Contact captivation-axial	≥ 4 lbs	Durability (mating)	≥ 500										
Mechanical Data																					
Disengagement force	1.8 to 14.2 lbs																				
Engagement force	1.8 to 14.2 lbs																				
Contact captivation-axial	≥ 4 lbs																				
Durability (mating)	≥ 500																				
<table border="0"> <tr> <td colspan="2" data-bbox="167 1288 569 1332">Environmental Data</td> </tr> <tr> <td data-bbox="167 1344 829 1377">Temperature range</td> <td data-bbox="853 1344 1133 1377">-65°C to +165°C</td> </tr> <tr> <td data-bbox="167 1388 829 1422">Thermal shock</td> <td data-bbox="853 1388 1133 1422">MIL-STD-202, Method 107, Condition B</td> </tr> <tr> <td data-bbox="167 1433 829 1467">Moisture resistance</td> <td data-bbox="853 1433 1133 1467">MIL-STD-202, Method 106</td> </tr> <tr> <td data-bbox="167 1478 829 1512">Corrosion</td> <td data-bbox="853 1478 1133 1512">MIL-STD-202, Method 101, Condition B</td> </tr> <tr> <td data-bbox="167 1523 829 1556">RoHS</td> <td data-bbox="853 1523 1133 1556">Compliant</td> </tr> </table>		Environmental Data		Temperature range	-65°C to +165°C	Thermal shock	MIL-STD-202, Method 107, Condition B	Moisture resistance	MIL-STD-202, Method 106	Corrosion	MIL-STD-202, Method 101, Condition B	RoHS	Compliant								
Environmental Data																					
Temperature range	-65°C to +165°C																				
Thermal shock	MIL-STD-202, Method 107, Condition B																				
Moisture resistance	MIL-STD-202, Method 106																				
Corrosion	MIL-STD-202, Method 101, Condition B																				
RoHS	Compliant																				
<table border="0"> <tr> <td colspan="2" data-bbox="167 1646 569 1691">Tooling</td> </tr> </table>		Tooling																			
Tooling																					

Notice: JYEBAO reserves the right to make modifications deemed appropriate.

SMB3400-9075

S11

