

SMA9400-9000

**SMA Reverse Polarity Jack PCB Mount Right Angle
With Round Contact (Φ1.27); 5GHz VSWR 1.2**

50Ω

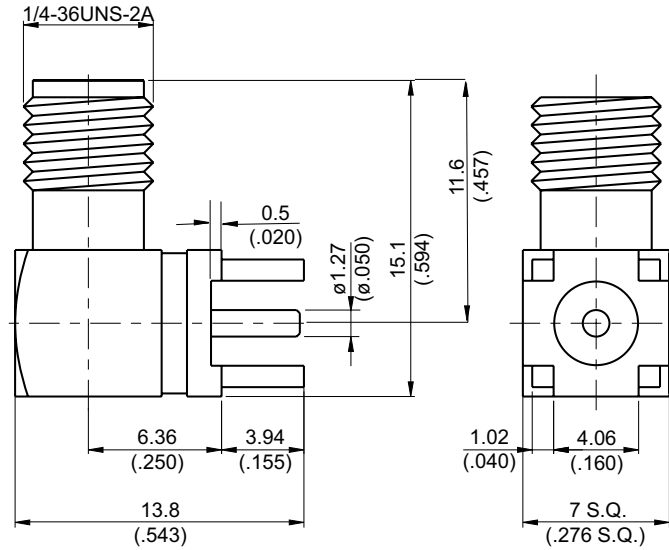

MOUNTING HOLE :

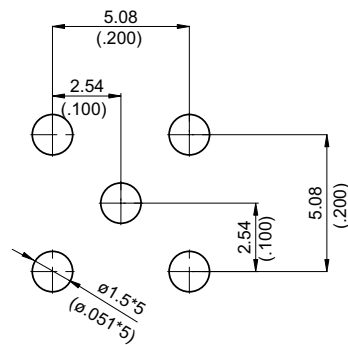

Parts	Material	Plating (Micro-inch)
Part	Brass	Gold 4 Over Nickel-Phosphorus Alloy 80 Over Copper 20
Cover	Brass	Gold 4 Over Nickel-Phosphorus Alloy 80 Over Copper 20
Contact Pin	Brass	Gold 4 Over Nickel-Phosphorus Alloy 80 Over Copper 20
Insulator	Teflon	
Body	Brass	Gold 4 Over Nickel-Phosphorus Alloy 80 Over Copper 20
Housing	Brass	Gold 4 Over Nickel-Phosphorus Alloy 80 Over Copper 20

Weight: 3.66 g

This part number complies with RoHS.

Notice: JYEBAO reserves the right to make modifications deemed appropriate.

SMA	SMA9400-9000																		
<div data-bbox="167 383 568 432" style="border: 1px solid black; padding: 2px;">Interface</div> <p>Per JYEBAO SMA Jack Reverse Polarity derived from MIL-STD-348B.</p>																			
<div data-bbox="167 551 568 600" style="border: 1px solid black; padding: 2px;">Electrical Data</div> <table border="0" style="width: 100%;"> <tr> <td style="width: 50%;">Impedance</td> <td style="width: 50%;">50Ω</td> </tr> <tr> <td>Frequency range</td> <td>DC to 5GHz</td> </tr> <tr> <td>VSWR</td> <td>≤ 1.2 (DC to 5GHz)</td> </tr> <tr> <td>Insertion loss</td> <td>≤ 0.04 x √f(GHz) dB</td> </tr> <tr> <td>Insulation resistance</td> <td>≥ 5000MΩ</td> </tr> <tr> <td>Contact resistance inner conductor</td> <td>≤ 3mΩ</td> </tr> <tr> <td>Contact resistance outer conductor</td> <td>≤ 2mΩ</td> </tr> <tr> <td>Dielectric withstanding voltage (at sea level)</td> <td>1500 V rms</td> </tr> <tr> <td>Working voltage (at sea level)</td> <td>500 V rms</td> </tr> </table>		Impedance	50Ω	Frequency range	DC to 5GHz	VSWR	≤ 1.2 (DC to 5GHz)	Insertion loss	≤ 0.04 x √f(GHz) dB	Insulation resistance	≥ 5000MΩ	Contact resistance inner conductor	≤ 3mΩ	Contact resistance outer conductor	≤ 2mΩ	Dielectric withstanding voltage (at sea level)	1500 V rms	Working voltage (at sea level)	500 V rms
Impedance	50Ω																		
Frequency range	DC to 5GHz																		
VSWR	≤ 1.2 (DC to 5GHz)																		
Insertion loss	≤ 0.04 x √f(GHz) dB																		
Insulation resistance	≥ 5000MΩ																		
Contact resistance inner conductor	≤ 3mΩ																		
Contact resistance outer conductor	≤ 2mΩ																		
Dielectric withstanding voltage (at sea level)	1500 V rms																		
Working voltage (at sea level)	500 V rms																		
<div data-bbox="167 1093 568 1142" style="border: 1px solid black; padding: 2px;">Mechanical Data</div> <table border="0" style="width: 100%;"> <tr> <td style="width: 50%;">Recommended coupling nut torque</td> <td style="width: 50%;">4 inch lbs</td> </tr> <tr> <td>Coupling proof torque</td> <td>5.3 inch lbs</td> </tr> <tr> <td>Contact Captivation-axial</td> <td>≥ 6.1 lbs</td> </tr> <tr> <td>Durability (mating)</td> <td>≥ 100</td> </tr> </table>		Recommended coupling nut torque	4 inch lbs	Coupling proof torque	5.3 inch lbs	Contact Captivation-axial	≥ 6.1 lbs	Durability (mating)	≥ 100										
Recommended coupling nut torque	4 inch lbs																		
Coupling proof torque	5.3 inch lbs																		
Contact Captivation-axial	≥ 6.1 lbs																		
Durability (mating)	≥ 100																		
<div data-bbox="167 1400 568 1449" style="border: 1px solid black; padding: 2px;">Environmental Data</div> <table border="0" style="width: 100%;"> <tr> <td style="width: 50%;">Temperature range</td> <td style="width: 50%;">-65°C to +165°C</td> </tr> <tr> <td>Thermal shock</td> <td>MIL-STD-202, Method 107, Condition B</td> </tr> <tr> <td>Moisture resistance</td> <td>MIL-STD-202, Method 106</td> </tr> <tr> <td>Corrosion</td> <td>MIL-STD-202, Method 101, Condition B</td> </tr> <tr> <td>RoHS</td> <td>Compliant</td> </tr> </table>		Temperature range	-65°C to +165°C	Thermal shock	MIL-STD-202, Method 107, Condition B	Moisture resistance	MIL-STD-202, Method 106	Corrosion	MIL-STD-202, Method 101, Condition B	RoHS	Compliant								
Temperature range	-65°C to +165°C																		
Thermal shock	MIL-STD-202, Method 107, Condition B																		
Moisture resistance	MIL-STD-202, Method 106																		
Corrosion	MIL-STD-202, Method 101, Condition B																		
RoHS	Compliant																		
<div data-bbox="167 1749 568 1798" style="border: 1px solid black; padding: 2px;">Tooling</div>																			

Notice: JYEBAO reserves the right to make modifications deemed appropriate.

SMA9400-9000

S11

