

SMA8F46EC-EM09

SMA Field Replaceable Jack
 SQ 12.7mm (.500inch) 4 Hole Flange With Metal Ring
 Accepts $\phi 0.23\text{mm}$ (.009inch) pin, 27GHz VSWR1.15

50 Ω

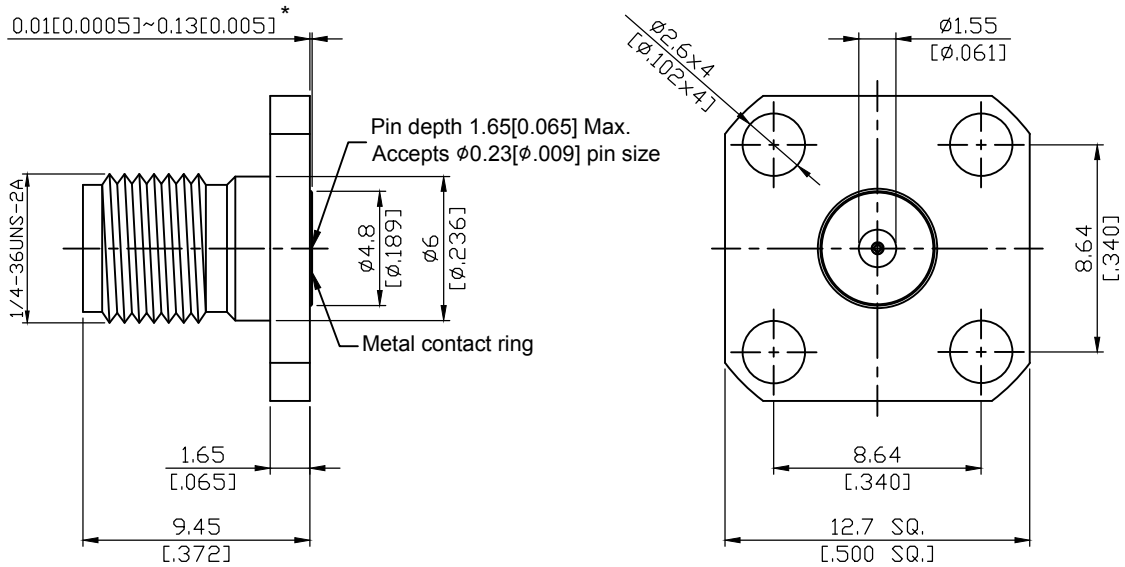

*360° Raised Metal Contact Ring

Parts	Material	Plating (Micro-inch)
Body	Stainless Steel	Passivated
Insulator	Teflon	
Contact Pin	Beryllium Copper	Gold 4 Over Nickel-Phosphorus Alloy 80 Over Copper 20
Metal Contact Ring	Stainless Steel	Passivated

This part number complies with RoHS.

Notice: JYEBAO reserves the right to make modifications deemed appropriate.

SMA	SMA8F46EC-EM09
Interface	
MIL-STD-348B	
Mechanically compatible with	2.92 & 3.5
Electrical Data	
Impedance	50Ω
Frequency range	DC to 27GHz
VSWR	≤ 1.15 (DC to 27GHz)
Insertion loss	≤ 0.04 x √f(GHz) dB
Insulation resistance	≥ 5000MΩ
Contact resistance inner conductor	≤ 3mΩ
Contact resistance outer conductor	≤ 2mΩ
Dielectric withstanding voltage (at sea level)	1500 V rms
Working voltage (at sea level)	500 V rms
Mechanical Data	
Recommended coupling nut torque	7 to 9.5 inch lbs
Coupling proof torque	15 inch lbs
Contact Captivation-axial	≥ 6.1 lbs
Durability (mating)	≥ 500
Environmental Data	
Temperature range	-65°C to +165°C
Thermal shock	MIL-STD-202, Method 107, Condition B
Moisture resistance	MIL-STD-202, Method 106
Corrosion	MIL-STD-202, Method 101, Condition B
RoHS	Compliant
Accessories	
Hermetic seal	FR009-SEAL1
Launch pin & Dielectric transition	FR009-LAUNCH1; FR009-LAUNCH2
Tab pin & Dielectric transition	FR009-TAB2; FR009-TAB3
Tab pin	FR009-TAB1

Notice: JYEBAO reserves the right to make modifications deemed appropriate.

Recommended Launch Hole Dimensions :

1. Using Hermetic seals

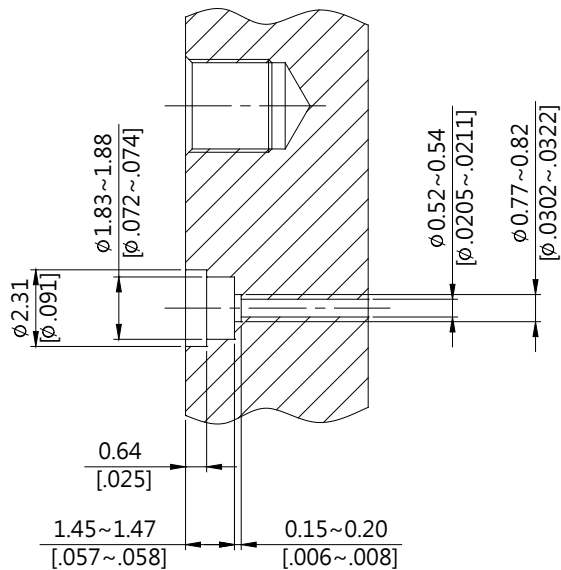

Hermetic seal P/N

FR009-SEAL1

2. Using dielectric with Tab or Launch pin

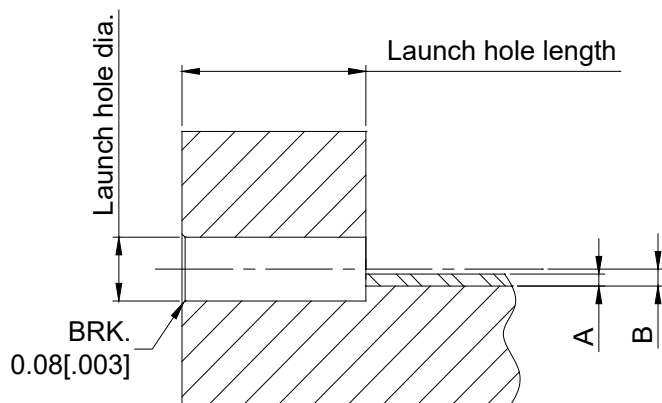

"A" = Substrate thickness

"B" = A + 1/2 Tab or Launch terminal

Dielectric and Tab/ Launch pin P/N	Recommended Launch hole dia.	Recommended Launch hole length
FR009-LAUNCH1	$\phi 0.74 (.029)$	4.75 (.187)
FR009-LAUNCH2	$\phi 0.74 (.029)$	3.18 (.125)
FR009-TAB2	$\phi 0.74 (.029)$	3.18 (.125)
FR009-TAB3	$\phi 0.74 (.029)$	4.75 (.187)

3. Using Tab pin

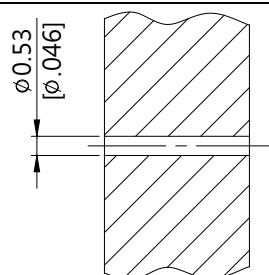

Tab pin P/N

FR009-TAB1

SMA8F46EC-EM09 (Tested back to back)

