

SMA8F26EE-EM20

SMA Field Replaceable Jack
 $\phi 13.97\text{mm}$ (.550inch) 2 Hole Flange With Metal Ring
 Accepts $\phi 0.51\text{mm}$ (.020inch) pin; 27GHz VSWR 1.15

50 Ω

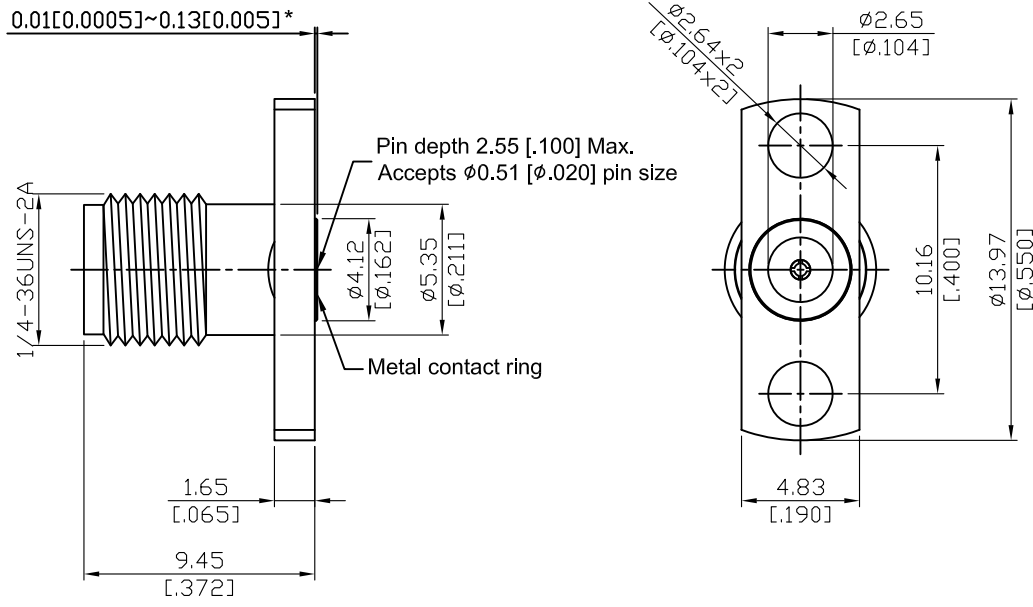

*360° Raised Metal Contact Ring

Parts	Material	Plating (Micro-inch)
Body	Stainless Steel	Passivated
Insulator	Teflon	
Contact Pin	Beryllium Copper	Gold 4 Over Nickel-Phosphorus Alloy 80 Over Copper 20
Metal Contact Ring	Stainless Steel	Passivated

This part number complies with RoHS.

Notice: JYEBAO reserves the right to make modifications deemed appropriate.

SMA	SMA8F26EE-EM20
Interface	
MIL-STD-348A	
Mechanically compatible with	2.92 & 3.5
Electrical Data	
Impedance	50Ω
Frequency range	DC to 27GHz
VSWR	≤ 1.15 (DC to 27GHz)
Insertion loss	≤ 0.04 x √f(GHz) dB
Insulation resistance	≥ 5000MΩ
Contact resistance inner conductor	≤ 3mΩ
Contact resistance outer conductor	≤ 2mΩ
Dielectric withstanding voltage (at sea level)	750 V rms
Working voltage (at sea level)	250 V rms
Mechanical Data	
Recommended coupling nut torque	7 to 9.5 inch lbs
Coupling proof torque	15 inch lbs
Contact Captivation-axial	≥ 6.1 lbs
Durability (mating)	≥ 500
Environmental Data	
Temperature range	-65°C to +165°C
Thermal shock	MIL-STD-202, Method 107, Condition B
Moisture resistance	MIL-STD-202, Method 106
Corrosion	MIL-STD-202, Method 101, Condition B
RoHS	Compliant
Accessories	
Hermetic seal	SEAL.02
Launch pin & Dielectric transition	FR020-LAUNCH1; FR020-LAUNCH2
Tab pin & Dielectric transition	FR020-TAB2; FR020-TAB3
Tab pin	FR020-TAB1; FRPIN.02

Notice: JYEBAO reserves the right to make modifications deemed appropriate.

Recommended Launch Hole Dimensions :

1. Using Hermetic seals

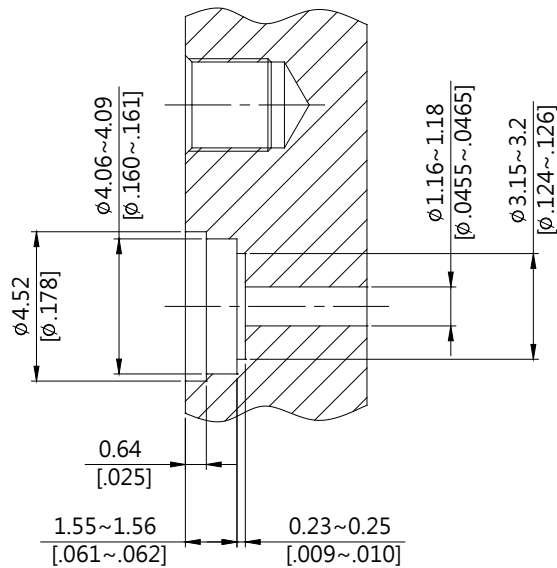

Hermetic seal P/N

SEAL.02

2. Using dielectric with Tab or Launch pin



"A" = Substrate thickness

"B" = A + 1/2 Tab or Launch terminal

Dielectric and Tab/Launch pin P/N	Recommended Launch hole dia.	Recommended Launch hole length
FR020-LAUNCH1	ϕ 1.63 (.064)	4.75 (.187)
FR020-LAUNCH2	ϕ 1.63 (.064)	3.18 (.125)
FR020-TAB2	ϕ 1.63 (.064)	4.75 (.187)
FR020-TAB3	ϕ 1.63 (.064)	3.18 (.125)

3. Using Tab pin

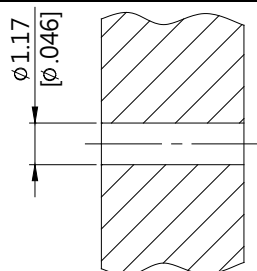

Tab pin P/N

FR020-TAB1

FRPIN.02

SMA8F26EE-EM20 (Tested back to back)

S11

