

SMA8F26EE-EM18

SMA Field Replaceable Jack
 $\phi 13.97\text{mm}$ (.550inch) 2 Hole Flange With Metal Ring
 Accepts $\phi 0.46\text{mm}$ (.018inch) pin; 27GHz VSWR 1.15

50 Ω

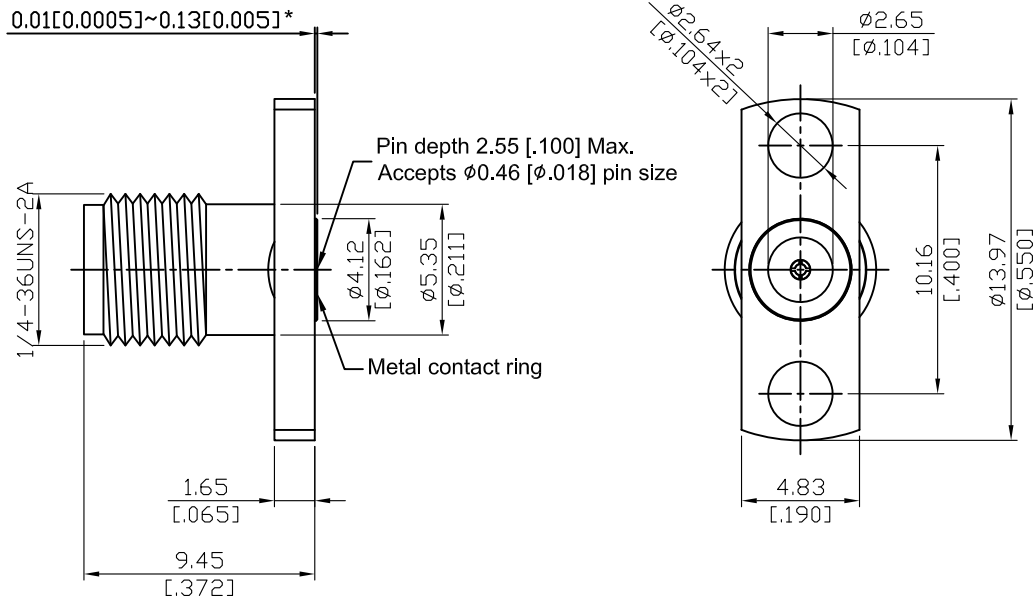

*360° Raised Metal Contact Ring

Parts	Material	Plating (Micro-inch)
Body	Stainless Steel	Passivated
Insulator	Teflon	
Contact Pin	Beryllium Copper	Gold 4 Over Nickel-Phosphorus Alloy 80 Over Copper 20
Metal Contact Ring	Stainless Steel	Passivated

This part number complies with RoHS.

Notice: JYEBAO reserves the right to make modifications deemed appropriate.

SMA	SMA8F26EE-EM18
<div style="border: 1px solid black; padding: 2px; margin-bottom: 5px;">Interface</div> MIL-STD-348A Mechanically compatible with 2.92 & 3.5	
<div style="border: 1px solid black; padding: 2px; margin-bottom: 5px;">Electrical Data</div> Impedance 50Ω Frequency range DC to 27GHz VSWR ≤ 1.15 (DC to 27GHz) Insertion loss $\leq 0.04 \times \sqrt{f(\text{GHz})}$ dB Insulation resistance $\geq 5000\text{M}\Omega$ Contact resistance inner conductor $\leq 3\text{m}\Omega$ Contact resistance outer conductor $\leq 2\text{m}\Omega$ Dielectric withstanding voltage (at sea level) 1500 V rms Working voltage (at sea level) 500 V rms	
<div style="border: 1px solid black; padding: 2px; margin-bottom: 5px;">Mechanical Data</div> Recommended coupling nut torque 7 to 9.5 inch lbs Coupling proof torque 15 inch lbs Contact Captivation-axial ≥ 6.1 lbs Durability (mating) ≥ 500	
<div style="border: 1px solid black; padding: 2px; margin-bottom: 5px;">Environmental Data</div> Temperature range -65°C to +165°C Thermal shock MIL-STD-202, Method 107, Condition B Moisture resistance MIL-STD-202, Method 106 Corrosion MIL-STD-202, Method 101, Condition B RoHS Compliant	
<div style="border: 1px solid black; padding: 2px; margin-bottom: 5px;">Accessories</div> Hermetic seal SEAL.018	

Notice: JYEBAO reserves the right to make modifications deemed appropriate.

Recommended Launch Hole Dimensions :

1. Using Hermetic seals

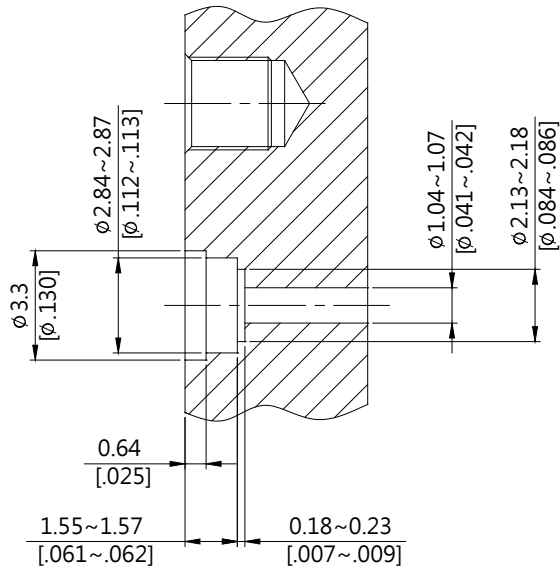

Hermetic seal P/N

SEAL.018

SMA8F26EE-EM18 (Tested back to back)

