

SMA864K1-0000

**SMA Jack SQ 12.7mm 4 Hole Flange
With Half Moon Contact (Φ 1.27;L=2.54);
9GHz VSWR 1.2**

50 Ω

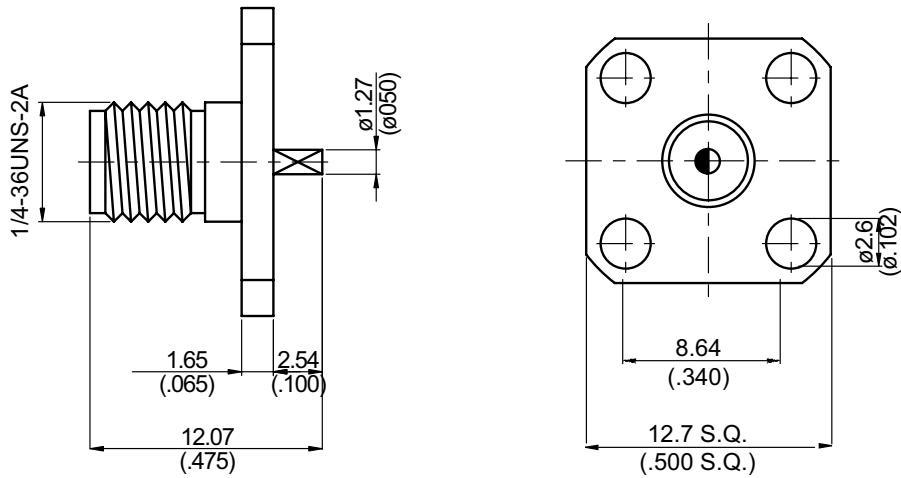

Parts	Material	Plating (Micro-inch)
Part	Brass	Gold 4 Over Nickel-Phosphorus Alloy 80 Over Copper 20
Contact Pin	Beryllium Copper	Gold 4 Over Nickel-Phosphorus Alloy 80 Over Copper 20
Insulator	Teflon	
Body	Brass	Gold 4 Over Nickel-Phosphorus Alloy 80 Over Copper 20

Weight: 3.02 g

This part number complies with RoHS.

Notice: JYEBAO reserves the right to make modifications deemed appropriate.

SMA	SMA864K1-0000
<div data-bbox="167 383 568 432" style="border: 1px solid black; padding: 2px;">Interface</div> <p>MIL-STD-348B</p> <p>Mechanically compatible with 2.92 & 3.5</p>	
<div data-bbox="167 551 568 600" style="border: 1px solid black; padding: 2px;">Electrical Data</div> <p>Impedance 50Ω</p> <p>Frequency range DC to 9GHz</p> <p>VSWR ≤ 1.2 (DC to 9GHz)</p> <p>Insertion loss $\leq 0.04 \times \sqrt{f(\text{GHz})}$ dB</p> <p>Insulation resistance $\geq 5000\text{M}\Omega$</p> <p>Contact resistance inner conductor $\leq 3\text{m}\Omega$</p> <p>Contact resistance outer conductor $\leq 2\text{m}\Omega$</p> <p>Dielectric withstanding voltage (at sea level) 1500 V rms</p> <p>Working voltage (at sea level) 500 V rms</p>	
<div data-bbox="167 1093 568 1142" style="border: 1px solid black; padding: 2px;">Mechanical Data</div> <p>Recommended coupling nut torque 4 inch lbs</p> <p>Coupling proof torque 5.3 inch lbs</p> <p>Contact Captivation-axial ≥ 6.1 lbs</p> <p>Durability (mating) ≥ 100</p>	
<div data-bbox="167 1400 568 1449" style="border: 1px solid black; padding: 2px;">Environmental Data</div> <p>Temperature range -65°C to +165°C</p> <p>Thermal shock MIL-STD-202, Method 107, Condition B</p> <p>Moisture resistance MIL-STD-202, Method 106</p> <p>Corrosion MIL-STD-202, Method 101, Condition B</p> <p>RoHS Compliant</p>	
<div data-bbox="167 1749 568 1798" style="border: 1px solid black; padding: 2px;">Tooling</div>	

Notice: JYEBAO reserves the right to make modifications deemed appropriate.

SMA864K1-0000

SoftPlot Measurement Presentation
S11

dB

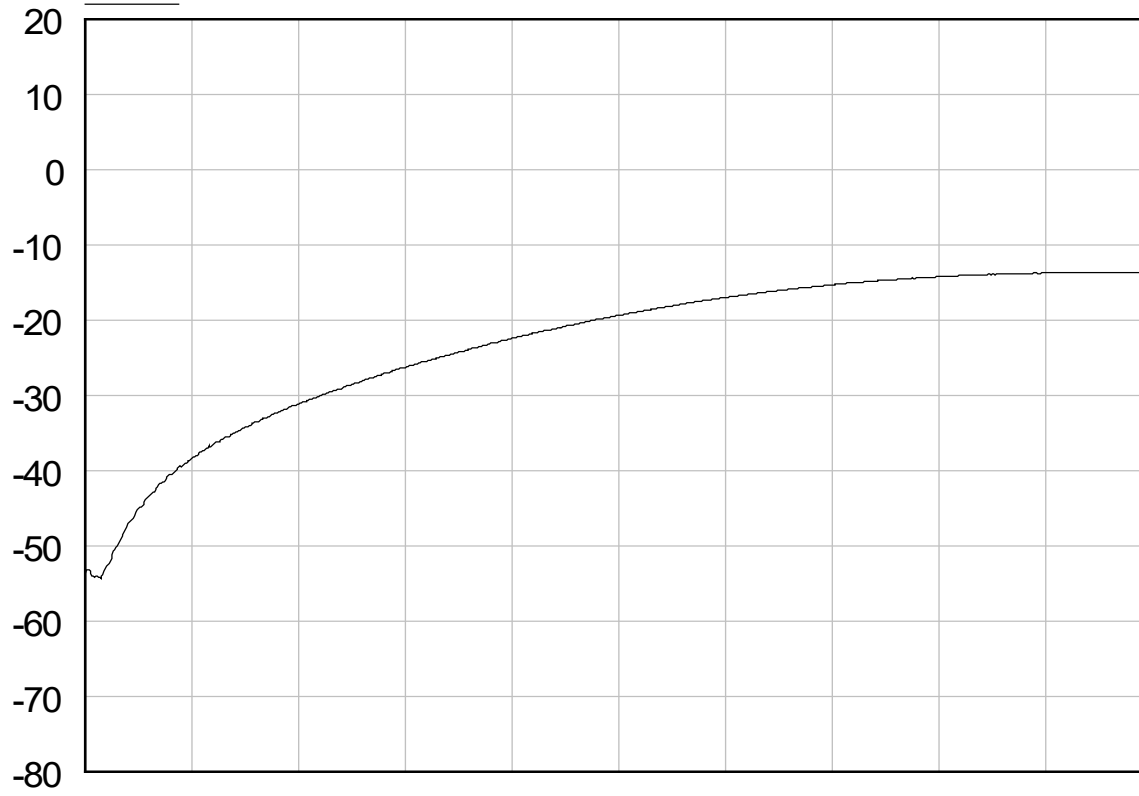

1 S11
▽ 17.9600 GHz
-13.61 dB