

SMA8640-10.35/1

SMA Jack SQ 12.7mm 4 Hole Flange With Round Contact ($\Phi 1.27$; L=1), PTFE L=10.35; 18GHz VSWR 1.2 50 Ω

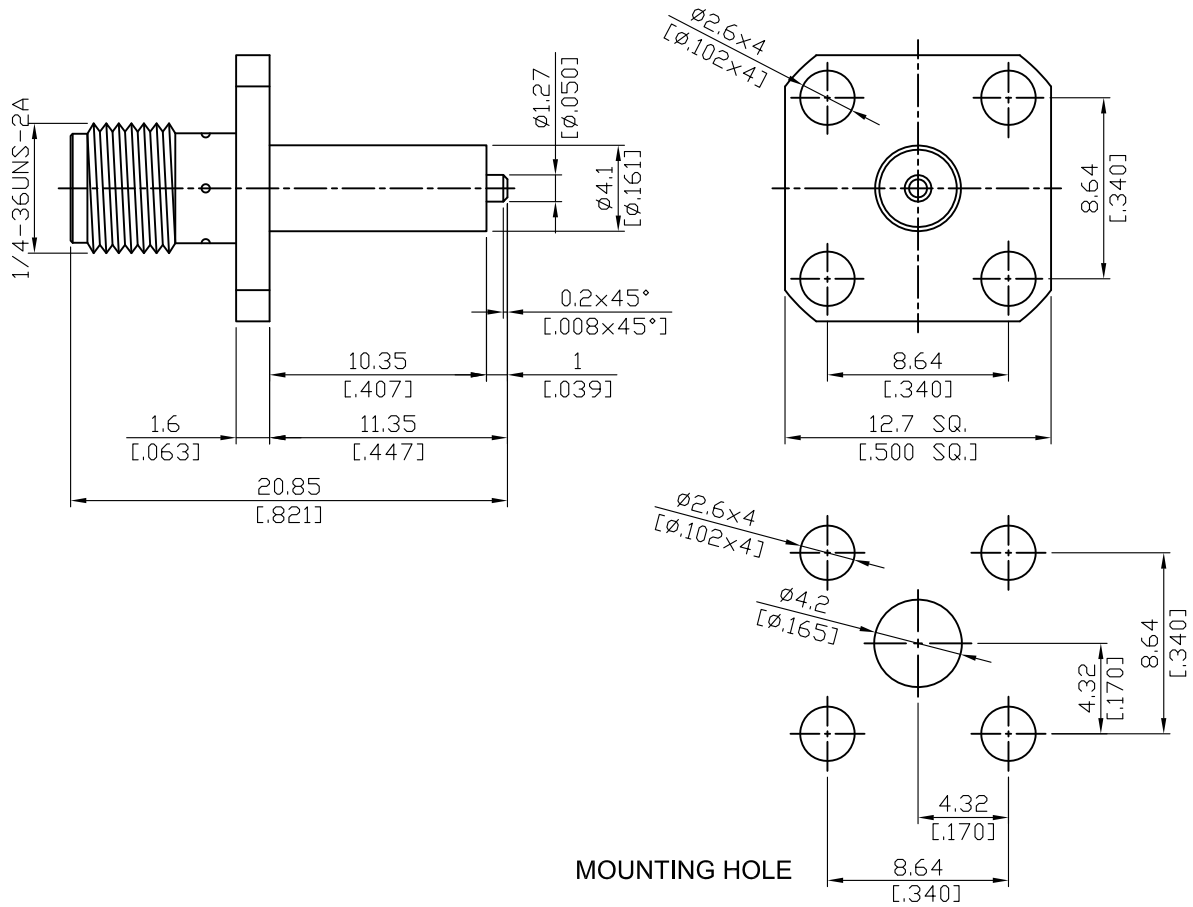

Parts	Material	Plating (Micro-inch)
Contact Pin	Beryllium Copper	Gold 4 Over Nickel-Phosphorus Alloy 80 Over Copper 20
Insulator	Teflon	
Body	Brass	Gold 4 Over Nickel-Phosphorus Alloy 80 Over Copper 20

This part number complies with RoHS.

Notice: JYEBAO reserves the right to make modifications deemed appropriate.

SMA	SMA8640-10.35/1
<div style="border: 1px solid black; padding: 2px; margin-bottom: 5px;">Interface</div> MIL-STD-348B Mechanically compatible with 2.92 & 3.5	
<div style="border: 1px solid black; padding: 2px; margin-bottom: 5px;">Electrical Data</div> Impedance 50Ω Frequency range DC to 18GHz VSWR ≤ 1.2 (DC to 18GHz) Insertion loss $\leq 0.04 \times \sqrt{f(\text{GHz})}$ dB Insulation resistance $\geq 5000\text{M}\Omega$ Contact resistance inner conductor $\leq 3\text{m}\Omega$ Contact resistance outer conductor $\leq 2\text{m}\Omega$ Dielectric withstanding voltage (at sea level) 1500 V rms Working voltage (at sea level) 500 V rms	
<div style="border: 1px solid black; padding: 2px; margin-bottom: 5px;">Mechanical Data</div> Recommended coupling nut torque 4 inch lbs Coupling proof torque 5.3 inch lbs Contact Captivation-axial ≥ 6.1 lbs Durability (mating) ≥ 100	
<div style="border: 1px solid black; padding: 2px; margin-bottom: 5px;">Environmental Data</div> Temperature range -65°C to +165°C Thermal shock MIL-STD-202, Method 107, Condition B Moisture resistance MIL-STD-202, Method 106 Corrosion MIL-STD-202, Method 101, Condition B RoHS Compliant	
<div style="border: 1px solid black; padding: 2px; margin-bottom: 5px;">Tooling</div>	

Notice: JYEBAO reserves the right to make modifications deemed appropriate.

SMA8640-10.35/1

S11

