

SMA862N2S-0000

SMA Jack $\phi 16\text{mm}$ 2 Hole Flange
With Round Contact ($\phi 0.3$; $L=0.5$), PTFE $L=4.05$; 50Ω
18GHz VSWR 1.2, 27GHz VSWR 1.3

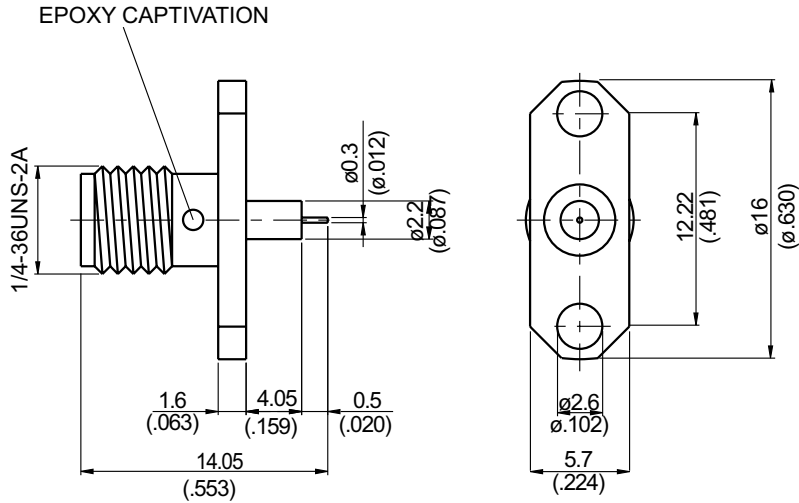

MOUNTING HOLE :

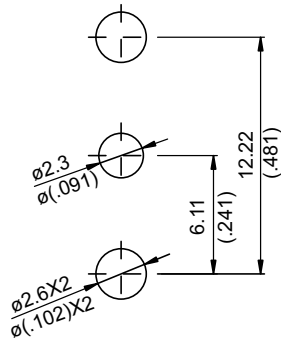

Parts	Material	Plating (Micro-inch)
Contact Pin	Beryllium Copper	Gold 4 Over Nickel-Phosphorus Alloy 80 Over Copper 20
Insulator	Teflon	
Body	Stainless	Passivated

This part number complies with RoHS.

Notice: JYEBAO reserves the right to make modifications deemed appropriate.

SMA	SMA862N2S-0000
<div data-bbox="167 344 568 389" style="border: 1px solid black; padding: 2px;">Interface</div> <p>MIL-STD-348B Mechanically compatible with 2.92 & 3.5</p>	
<div data-bbox="167 512 568 557" style="border: 1px solid black; padding: 2px;">Electrical Data</div> <p>Impedance 50Ω Frequency range DC to 27GHz VSWR ≤ 1.2 (18GHz); ≤ 1.3 (27GHz) Insertion loss $\leq 0.04 \times \sqrt{f(\text{GHz})}$ dB Insulation resistance $\geq 5000\text{M}\Omega$ Contact resistance inner conductor $\leq 3\text{m}\Omega$ Contact resistance outer conductor $\leq 2\text{m}\Omega$ Dielectric withstanding voltage (at sea level) 1500 V rms Working voltage (at sea level) 500 V rms</p>	
<div data-bbox="167 1057 568 1102" style="border: 1px solid black; padding: 2px;">Mechanical Data</div> <p>Recommended coupling nut torque 7 to 9.5 inch lbs Coupling proof torque 15 inch lbs Contact Captivation-axial ≥ 6.1 lbs Durability (mating) ≥ 500</p>	
<div data-bbox="167 1413 568 1458" style="border: 1px solid black; padding: 2px;">Environmental Data</div> <p>Temperature range -65°C to +165°C Thermal shock MIL-STD-202, Method 107, Condition B Moisture resistance MIL-STD-202, Method 106 Corrosion MIL-STD-202, Method 101, Condition B RoHS Compliant</p>	
<div data-bbox="167 1765 568 1809" style="border: 1px solid black; padding: 2px;">Tooling</div>	

Notice: JYEBAO reserves the right to make modifications deemed appropriate.

SMA862N2S-0000

S11

