

SMA862L-94.7/1.5

SMA jack $\phi 16\text{mm}$ 2 hole flange right angle with round contact ($\Phi 0.9$; $L=1.5$), PTFE $L=4.7$; 11GHz VSWR 1.2

50 Ω

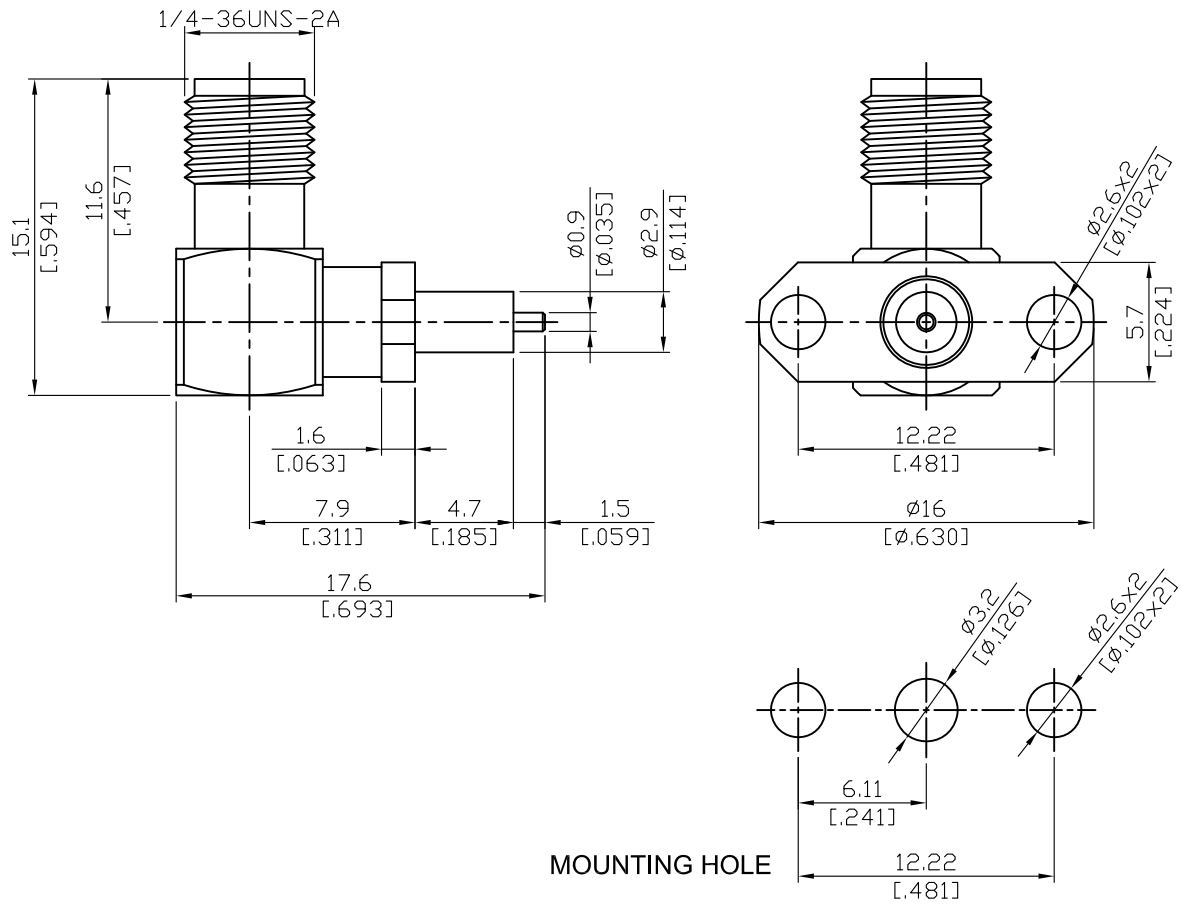

Parts	Material	Plating (Micro-inch)
Body	Brass	Gold 4 Over Nickel-Phosphorus Alloy 80 Over Copper 20
Insulator	Teflon	
Contact Pin	Beryllium Copper	Gold 4 Over Nickel-Phosphorus Alloy 80 Over Copper 20
Cover	Brass	Gold 4 Over Nickel-Phosphorus Alloy 80 Over Copper 20

This part number complies with RoHS.

Notice: JYEBAO reserves the right to make modifications deemed appropriate.

SMA	SMA862L-94.7/1.5
<div data-bbox="172 387 571 432" style="border: 1px solid black; padding: 2px;">Interface</div> <p>MIL-STD-348B</p> <p>Mechanically compatible with 2.92 & 3.5</p>	
<div data-bbox="172 555 571 600" style="border: 1px solid black; padding: 2px;">Electrical Data</div> <p>Impedance 50Ω</p> <p>Frequency range DC to 11GHz</p> <p>VSWR ≤ 1.2 (DC to 11GHz)</p> <p>Insertion loss $\leq 0.04 \times \sqrt{f(\text{GHz})}$ dB</p> <p>Insulation resistance $\geq 5000\text{M}\Omega$</p> <p>Contact resistance inner conductor $\leq 3\text{m}\Omega$</p> <p>Contact resistance outer conductor $\leq 2\text{m}\Omega$</p> <p>Dielectric withstanding voltage (at sea level) 1500 V rms</p> <p>Working voltage (at sea level) 500 V rms</p>	
<div data-bbox="172 1093 571 1137" style="border: 1px solid black; padding: 2px;">Mechanical Data</div> <p>Recommended coupling nut torque 4 inch lbs</p> <p>Coupling proof torque 5.3 inch lbs</p> <p>Coupling nut retention force ≥ 60.7 lbs</p> <p>Contact Captivation-axial ≥ 6.1 lbs</p> <p>Durability (mating) ≥ 100</p>	
<div data-bbox="172 1402 571 1447" style="border: 1px solid black; padding: 2px;">Environmental Data</div> <p>Temperature range -65°C to +165°C</p> <p>Thermal shock MIL-STD-202, Method 107, Condition B</p> <p>Moisture resistance MIL-STD-202, Method 106</p> <p>Corrosion MIL-STD-202, Method 101, Condition B</p> <p>RoHS Compliant</p>	
<div data-bbox="172 1753 571 1798" style="border: 1px solid black; padding: 2px;">Tooling</div>	

Notice: JYEBAO reserves the right to make modifications deemed appropriate.

SMA862L-94.7/1.5

SoftPlot Measurement Presentation
VSWR S11

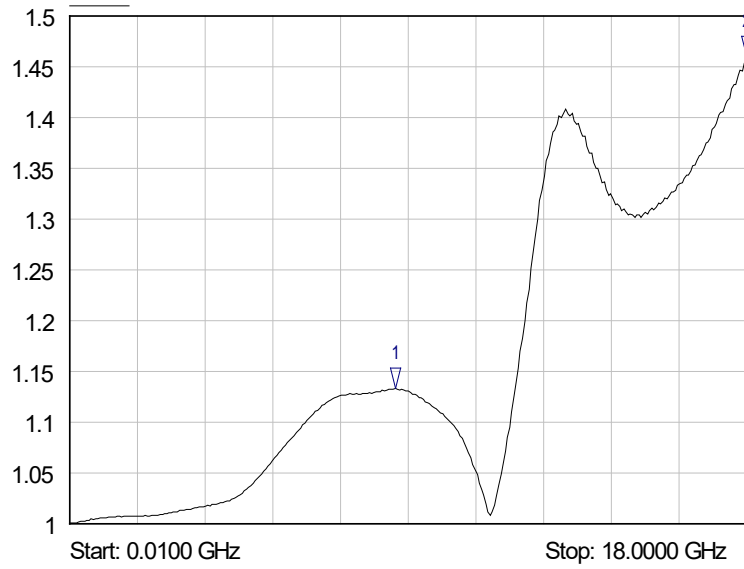

- 1 S11
▽ 8.6612 GHz
1.13 VSWR
- 2 S11
▽ 18.0000 GHz
1.46 VSWR