

SMA8502S-0000

SMA Jack Bulkhead With Solder Cup Contact; 50Ω
18GHz VSWR 1.2

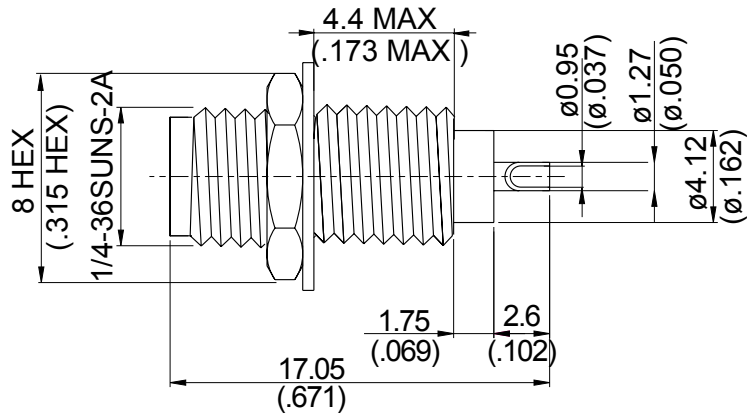

MOUNTING HOLE :

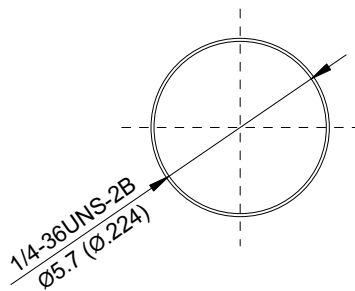

Parts	Material	Plating (Micro-inch)
Hex Nut	Stainless	Passivated
Lock Washer	Stainless	Passivated
Contact Pin	Beryllium Copper	Gold 4 Over Nickel-Phosphorus Alloy 80 Over Copper 20
Insulator	Teflon	
Body	Stainless	Passivated

Weight: 2.18 g

This part number complies with RoHS.

Notice: JYEBAO reserves the right to make modifications deemed appropriate.

SMA	SMA8502S-0000
<div data-bbox="167 344 568 392" style="border: 1px solid black; padding: 2px;">Interface</div> <p>MIL-STD-348B Mechanically compatible with 2.92 & 3.5</p>	
<div data-bbox="167 512 568 560" style="border: 1px solid black; padding: 2px;">Electrical Data</div> <p>Impedance 50Ω Frequency range DC to 18GHz VSWR ≤ 1.2 (DC to 18GHz) Insertion loss $\leq 0.04 \times \sqrt{f(\text{GHz})}$ dB Insulation resistance $\geq 5000\text{M}\Omega$ Contact resistance inner conductor $\leq 3\text{m}\Omega$ Contact resistance outer conductor $\leq 2\text{m}\Omega$ Dielectric withstanding voltage (at sea level) 1500 V rms Working voltage (at sea level) 500 V rms</p>	
<div data-bbox="167 1057 568 1104" style="border: 1px solid black; padding: 2px;">Mechanical Data</div> <p>Recommended coupling nut torque 7 to 9.5 inch lbs Coupling proof torque 15 inch lbs Contact Captivation-axial ≥ 6.1 lbs Durability (mating) ≥ 500</p>	
<div data-bbox="167 1413 568 1460" style="border: 1px solid black; padding: 2px;">Environmental Data</div> <p>Temperature range -65°C to +165°C Thermal shock MIL-STD-202, Method 107, Condition B Moisture resistance MIL-STD-202, Method 106 Corrosion MIL-STD-202, Method 101, Condition B RoHS Compliant</p>	
<div data-bbox="167 1765 568 1812" style="border: 1px solid black; padding: 2px;">Tooling</div>	

Notice: JYEBAO reserves the right to make modifications deemed appropriate.

SMA8502S-0000

S11

