

SMA8400C-9000

SMA Jack PCB Mount Right Angle With Round Contact (Φ1.27); 16GHz VSWR 1.2; 18GHz VSWR 1.35 50Ω

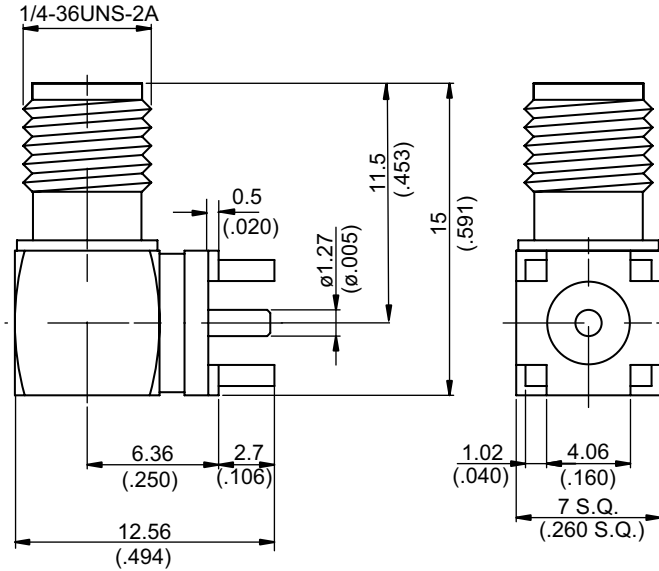

MOUNTING HOLE :

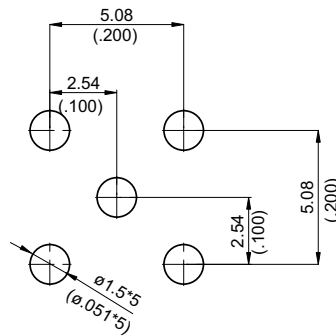

Parts	Material	Plating (Micro-inch)
Body	Brass	Gold 4 Over Nickel-Phosphorus Alloy 80 Over Copper 20
Cover	Brass	Gold 4 Over Nickel-Phosphorus Alloy 80 Over Copper 20
Contact Pin	Beryllium Copper	Gold 4 Over Nickel-Phosphorus Alloy 80 Over Copper 20
Insulator	Teflon	

Weight: 3.73 g

This part number complies with RoHS.

Notice: JYEBAO reserves the right to make modifications deemed appropriate.

SMA	SMA8400C-9000
<b>Interface</b>	
MIL-STD-348B	
Mechanically compatible with	2.92 & 3.5
<b>Electrical Data</b>	
Impedance	50Ω
Frequency range	DC to 18GHz
VSWR	≤ 1.2 (16GHz) ; ≤ 1.35 (18GHz)
Insertion loss	≤ 0.04 x √f(GHz) dB
Insulation resistance	≥ 5000MΩ
Contact resistance inner conductor	≤ 3mΩ
Contact resistance outer conductor	≤ 2mΩ
Dielectric withstanding voltage (at sea level)	1500 V rms
Working voltage (at sea level)	500 V rms
<b>Mechanical Data</b>	
Recommended coupling nut torque	4 inch lbs
Coupling proof torque	5.3 inch lbs
Contact Captivation-axial	≥ 6.1 lbs
Durability (mating)	≥ 100
<b>Environmental Data</b>	
Temperature range	-65°C to +165°C
Thermal shock	MIL-STD-202, Method 107, Condition B
Moisture resistance	MIL-STD-202, Method 106
Corrosion	MIL-STD-202, Method 101, Condition B
RoHS	Compliant
<b>Tooling</b>	

Notice: JYEBAO reserves the right to make modifications deemed appropriate.

# SMA8400C-9000

S11

