

SMA3F26EA-EM09

SMA Field Replaceable Plug,  
 $\phi$  15.88mm (.625inch) 2 Hole Flange With Metal Ring  
 Accepts  $\phi$ 0.23mm (.009inch) pin 27GHz VSWR 1.15

50 $\Omega$

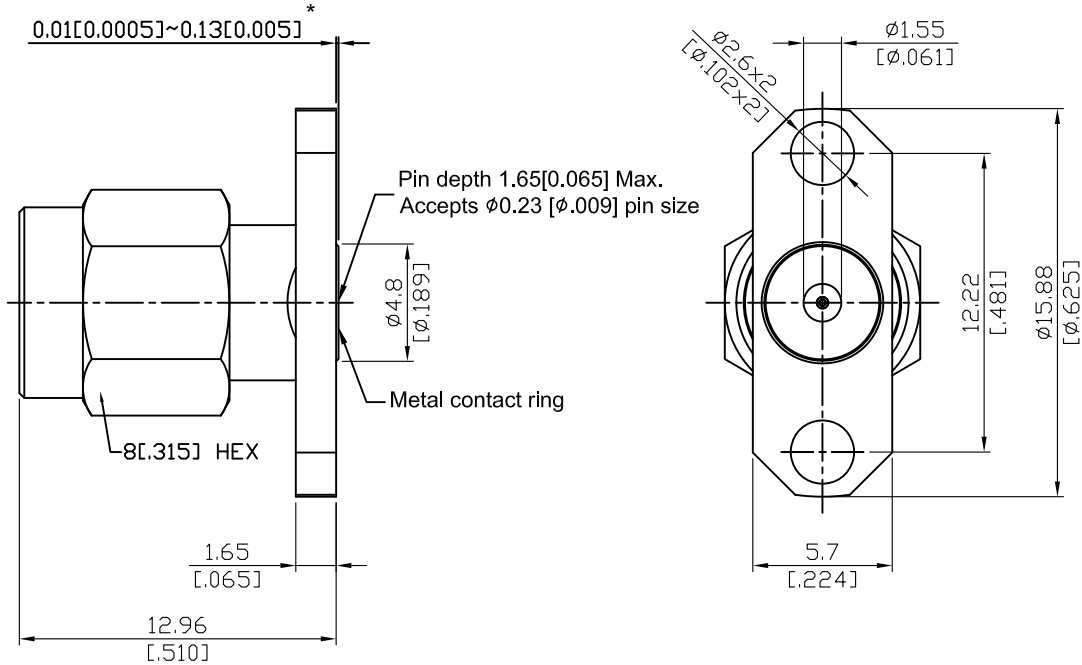

\*360° Raised Metal Contact Ring

Parts	Material	Plating ( Micro-inch )
Body	Stainless Steel	Passivated
Insulator	Teflon	
Contact Pin	Beryllium Copper	Gold 4 Over Nickel-Phosphorus Alloy 80 Over Copper 20
Metal Contact Ring	Stainless Steel	Passivated
Coupling Nut	Stainless Steel	Passivated
Retainer Ring	Beryllium Copper	Tin-Zinc-Copper-Alloy 100 Over Copper 50

This part number complies with RoHS.

Notice: JYEBAO reserves the right to make modifications deemed appropriate.

SMA	SMA3F26EA-EM09
<b>Interface</b>	
MIL-STD-348B	
Mechanically compatible with	2.92 & 3.5
<b>Electrical Data</b>	
Impedance	50Ω
Frequency range	DC to 27GHz
VSWR	≤ 1.15 (DC to 27GHz)
Insertion loss	≤ 0.04 x √f(GHz) dB
Insulation resistance	≥ 5000MΩ
Contact resistance inner conductor	≤ 3mΩ
Contact resistance outer conductor	≤ 2mΩ
Dielectric withstanding voltage (at sea level)	1500 V rms
Working voltage (at sea level)	500 V rms
<b>Mechanical Data</b>	
Recommended coupling nut torque	7 to 9.5 inch lbs
Coupling proof torque	15 inch lbs
Coupling nut retention force	≥ 60.7 lbs
Contact Captivation-axial	≥ 6.1 lbs
Durability (mating)	≥ 500
<b>Environmental Data</b>	
Temperature range	-65°C to +165°C
Thermal shock	MIL-STD-202, Method 107, Condition B
Moisture resistance	MIL-STD-202, Method 106
Corrosion	MIL-STD-202, Method 101, Condition B
RoHS	Compliant
<b>Accessories</b>	
Hermetic seal	FR009-SEAL1
Launch pin & Dielectric transition	FR009-LAUNCH1; FR009-LAUNCH2
Tab pin & Dielectric transition	FR009-TAB2; FR009-TAB3
Tab pin	FR009-TAB1

Notice: JYEBAO reserves the right to make modifications deemed appropriate.

## Recommended Launch Hole Dimensions :

### 1. Using Hermetic seals



Hermetic seal P/N

FR009-SEAL1

### 2. Using dielectric with Tab or Launch pin



"A" = Substrate thickness

"B" = A + 1/2 Tab or Launch terminal

Dielectric and Tab/ Launch pin P/N	Recommended Launch hole dia.	Recommended Launch hole length
FR009-LAUNCH1	$\phi 0.74 (.029)$	4.75 (.187)
FR009-LAUNCH2	$\phi 0.74 (.029)$	3.18 (.125)
FR009-TAB2	$\phi 0.74 (.029)$	3.18 (.125)
FR009-TAB3	$\phi 0.74 (.029)$	4.75 (.187)

### 3. Using Tab pin



Tab pin P/N

FR009-TAB1