

SMA362KS-0000

**SMA Plug,  $\phi$ 16mm 2 Hole Flange With Half Moon Contact ( $\Phi$ 1.27;L=2.5); 18GHz VSWR 1.2 50 $\Omega$**

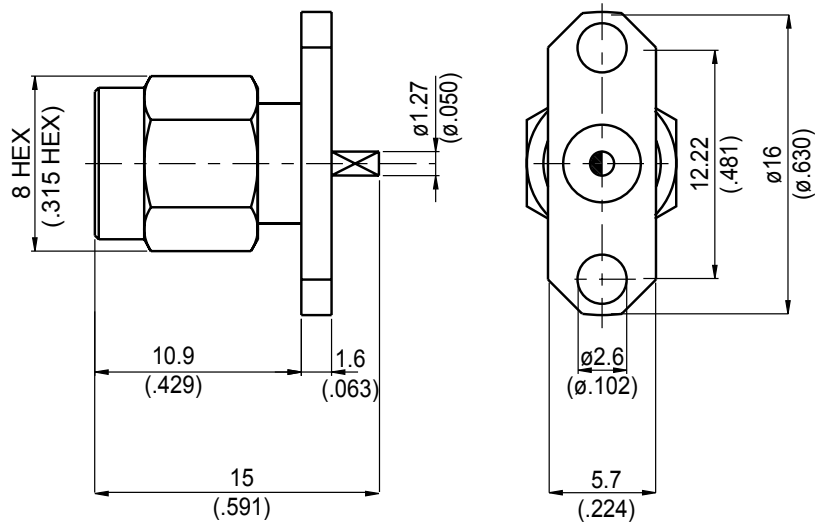

Parts	Material	Plating (Micro-inch)
Renber Ring	Beryllium Copper	Tin-Zinc-Copper-Alloy 100 Over Copper 50
Gasket	Silicon	
Contact Pin	Brass	Gold 4 Over Nickel-Phosphorus Alloy 80 Over Copper 20
Insulator	Teflon	
Body	Stainless	Passivated
Coupling Nut	Stainless	Passivated

Weight: 3.17 g

This part number complies with RoHS.

Notice: JYEBAO reserves the right to make modifications deemed appropriate.

SMA	SMA362KS-0000
<div style="border: 1px solid black; padding: 2px;">Interface</div> <p>MIL-STD-348B</p> <p>Mechanically compatible with 2.92 &amp; 3.5</p>	
<div style="border: 1px solid black; padding: 2px;">Electrical Data</div> <p>Impedance 50Ω</p> <p>Frequency range DC to 18GHz</p> <p>VSWR <math>\leq 1.2</math> (DC to 18GHz)</p> <p>Insertion loss <math>\leq 0.04 \times \sqrt{f(\text{GHz})}</math> dB</p> <p>Insulation resistance <math>\geq 5000\text{M}\Omega</math></p> <p>Contact resistance inner conductor <math>\leq 3\text{m}\Omega</math></p> <p>Contact resistance outer conductor <math>\leq 2\text{m}\Omega</math></p> <p>Dielectric withstanding voltage (at sea level) 1500 V rms</p> <p>Working voltage (at sea level) 500 V rms</p>	
<div style="border: 1px solid black; padding: 2px;">Mechanical Data</div> <p>Recommended coupling nut torque 7 to 9.5 inch lbs</p> <p>Coupling proof torque 15 inch lbs</p> <p>Coupling nut retention force <math>\geq 60.7</math> lbs</p> <p>Contact Captivation-axial <math>\geq 6.1</math> lbs</p> <p>Durability (mating) <math>\geq 500</math></p>	
<div style="border: 1px solid black; padding: 2px;">Environmental Data</div> <p>Temperature range -65°C to +165°C</p> <p>Thermal shock MIL-STD-202, Method 107, Condition B</p> <p>Moisture resistance MIL-STD-202, Method 106</p> <p>Corrosion MIL-STD-202, Method 101, Condition B</p> <p>RoHS Compliant</p>	
<div style="border: 1px solid black; padding: 2px;">Tooling</div>	

Notice: JYEBAO reserves the right to make modifications deemed appropriate.

# SMA362KS-0000

S11

