

SMA34NDA-0000

SMA Plug PCB Mount End Launch (T=0.5) With Tab
Contact (W=0.5;T=0.25;L=2.5); 12GHz VSWR 1.2

50Ω

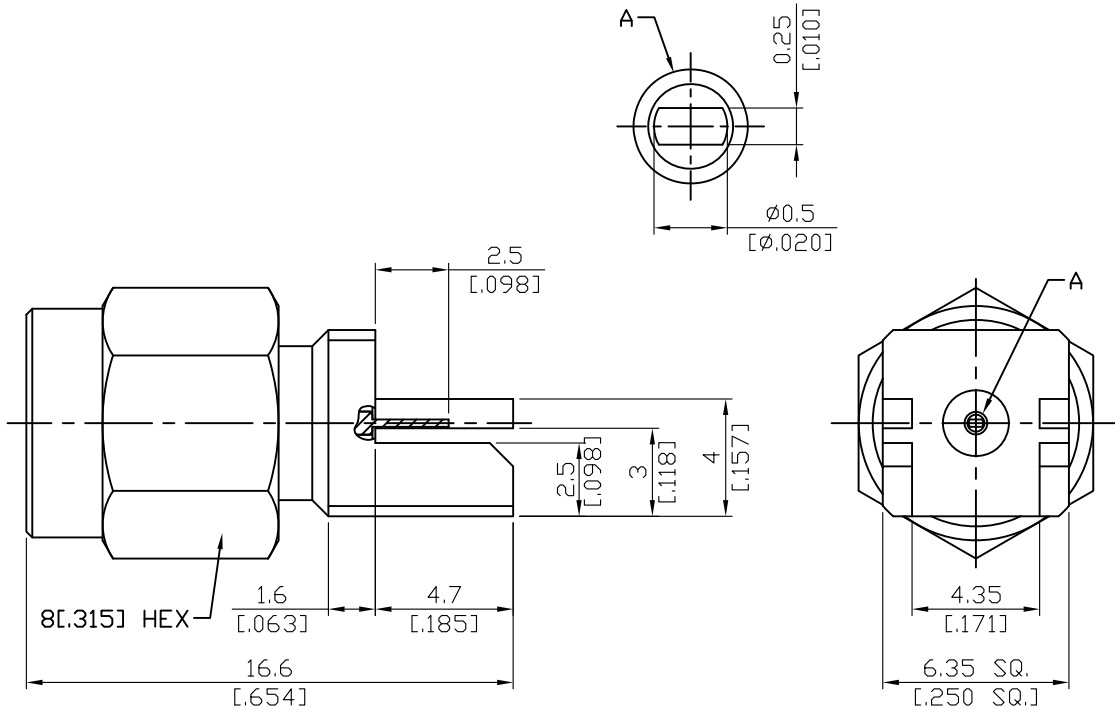

Parts	Material	Plating (Micro-inch)
Coupling Nut	Brass	Gold 4 Over Nickel-Phosphorus Alloy 80 Over Copper 20
Body	Brass	Gold 4 Over Nickel-Phosphorus Alloy 80 Over Copper 20
Insulator	Teflon	
Contact Pin	Brass	Gold 4 Over Nickel-Phosphorus Alloy 80 Over Copper 20
Gasket	Silicone	
Retainer Ring	Beryllium Copper	Tin-Zinc-Copper-Alloy 100 Over Copper 50

Weight: 3.16 g

This part number complies with RoHS.

Notice: JYEBAO reserves the right to make modifications deemed appropriate.

SMA	SMA34NDA-0000
<div data-bbox="172 387 571 432" style="border: 1px solid black; padding: 2px;">Interface</div> <p>MIL-STD-348B</p> <p>Mechanically compatible with 2.92 & 3.5</p>	
<div data-bbox="172 555 571 600" style="border: 1px solid black; padding: 2px;">Electrical Data</div> <p>Impedance 50Ω</p> <p>Frequency range DC to 12GHz</p> <p>VSWR ≤ 1.2 (DC to 12GHz)</p> <p>Insertion loss $\leq 0.04 \times \sqrt{f(\text{GHz})}$ dB</p> <p>Insulation resistance $\geq 5000\text{M}\Omega$</p> <p>Contact resistance inner conductor $\leq 3\text{m}\Omega$</p> <p>Contact resistance outer conductor $\leq 2\text{m}\Omega$</p> <p>Dielectric withstanding voltage (at sea level) 1500 V rms</p> <p>Working voltage (at sea level) 500 V rms</p>	
<div data-bbox="172 1093 571 1137" style="border: 1px solid black; padding: 2px;">Mechanical Data</div> <p>Recommended coupling nut torque 4 inch lbs</p> <p>Coupling proof torque 5.3 inch lbs</p> <p>Coupling nut retention force ≥ 60.7 lbs</p> <p>Contact Captivation-axial ≥ 6.1 lbs</p> <p>Durability (mating) ≥ 100</p>	
<div data-bbox="172 1406 571 1451" style="border: 1px solid black; padding: 2px;">Environmental Data</div> <p>Temperature range -65°C to +165°C</p> <p>Thermal shock MIL-STD-202, Method 107, Condition B</p> <p>Moisture resistance MIL-STD-202, Method 106</p> <p>Corrosion MIL-STD-202, Method 101, Condition B</p> <p>RoHS Compliant</p>	
<div data-bbox="172 1753 571 1798" style="border: 1px solid black; padding: 2px;">Tooling</div>	

Notice: JYEBAO reserves the right to make modifications deemed appropriate.

SMA34NDA-0000

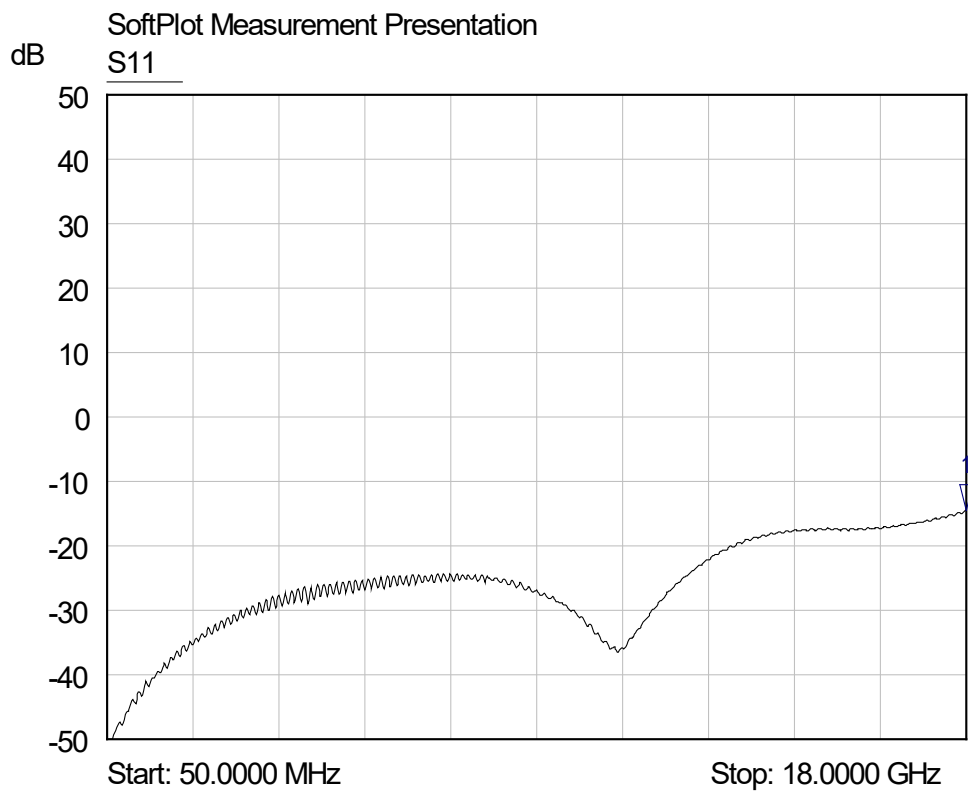

Mkr	Trace	X-Axis	Value	Notes
1 ▾	S11	18.0000 GHz	-14.49 dB	