

SMA3400M1-0000

SMA Plug PCB Mount End Launch (T=1.6) With Tab  
Contact (W=0.5;T=0.25;L=2.5); 27GHz VSWR 1.2

50Ω

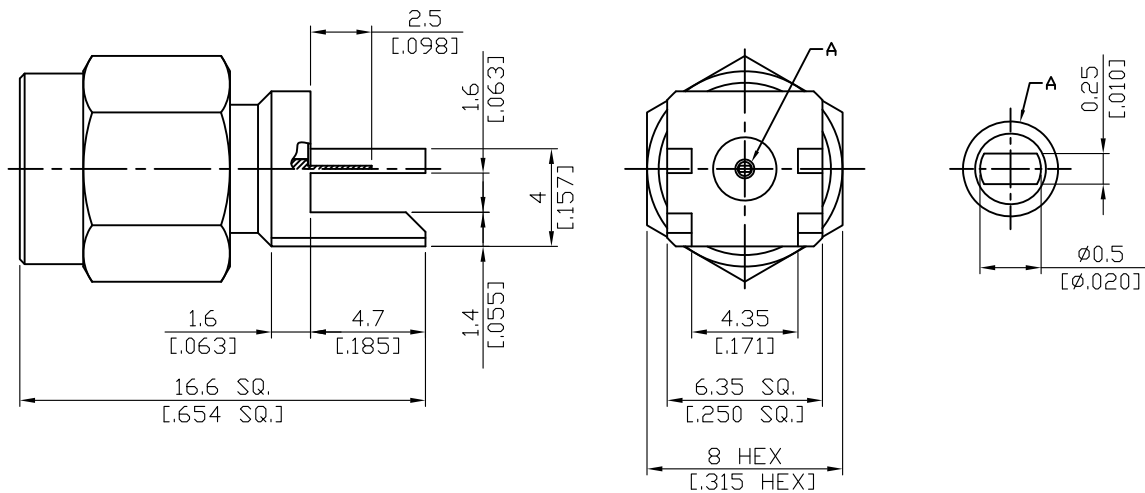

Parts	Material	Plating ( Micro-inch )
Retainer Ring	Beryllium Copper	Tin-Zinc-Copper-Alloy 100 Over Copper 50
Gasket	Silicone	
Contact Pin	Brass	Gold 4 Over Nickel-Phosphorus Alloy 80 Over Copper 20
Insulator	Teflon	
Body	Brass	Gold 4 Over Nickel-Phosphorus Alloy 80 Over Copper 20
Coupling Nut	Brass	Gold 4 Over Nickel-Phosphorus Alloy 80 Over Copper 20

This part number complies with RoHS.

Notice: JYEBAO reserves the right to make modifications deemed appropriate.

SMA	SMA3400M1-0000
<div data-bbox="167 383 568 427" style="border: 1px solid black; padding: 2px;">Interface</div> <p>MIL-STD-348B</p> <p>Mechanically compatible with 2.92 &amp; 3.5</p>	
<div data-bbox="167 551 568 595" style="border: 1px solid black; padding: 2px;">Electrical Data</div> <p>Impedance 50Ω</p> <p>Frequency range DC to 27GHz</p> <p>VSWR <math>\leq 1.2</math> (DC to 27GHz)</p> <p>Insertion loss <math>\leq 0.04 \times \sqrt{f(\text{GHz})}</math> dB</p> <p>Insulation resistance <math>\geq 5000\text{M}\Omega</math></p> <p>Contact resistance inner conductor <math>\leq 3\text{m}\Omega</math></p> <p>Contact resistance outer conductor <math>\leq 2\text{m}\Omega</math></p> <p>Dielectric withstanding voltage (at sea level) 1500 V rms</p> <p>Working voltage (at sea level) 500 V rms</p>	
<div data-bbox="167 1093 568 1137" style="border: 1px solid black; padding: 2px;">Mechanical Data</div> <p>Recommended coupling nut torque 4 inch lbs</p> <p>Coupling proof torque 5.3 inch lbs</p> <p>Coupling nut retention force <math>\geq 60.7</math> lbs</p> <p>Contact Captivation-axial <math>\geq 6.1</math> lbs</p> <p>Durability (mating) <math>\geq 100</math></p>	
<div data-bbox="167 1402 568 1447" style="border: 1px solid black; padding: 2px;">Environmental Data</div> <p>Temperature range -65°C to +165°C</p> <p>Thermal shock MIL-STD-202, Method 107, Condition B</p> <p>Moisture resistance MIL-STD-202, Method 106</p> <p>Corrosion MIL-STD-202, Method 101, Condition B</p> <p>RoHS Compliant</p>	
<div data-bbox="167 1749 568 1794" style="border: 1px solid black; padding: 2px;">Tooling</div>	

Notice: JYEBAO reserves the right to make modifications deemed appropriate.

# SMA3400M1-0000

S11

