

NO.	COMPONENTS	IMPEDANCE
1	3.5 FEMALE	50 OHM
2	5002A	50 OHM
3	SLEEVE	
4	3.5 NMD FEMALE	50 OHM

REVISION			
REV.	DESCRIPTON	DATE	APPROVED
-	INITIAL RELEASE	2020/12/07	

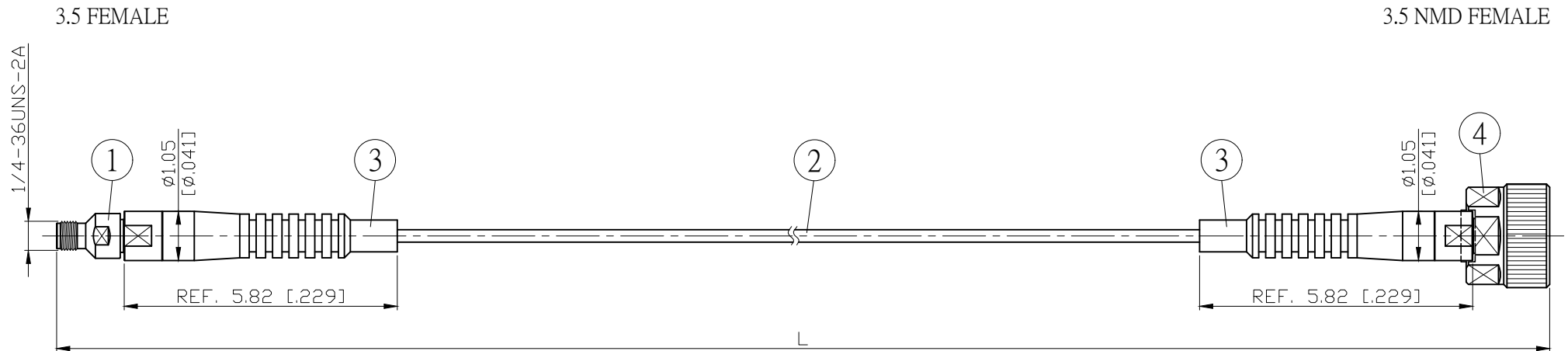

L CM (INCH)	L1 M (MM)
50 (19.685)	0.477 (477.0)
100 (39.370)	0.977 (977.0)
150 (59.055)	1.477 (1477.0)
200 (78.740)	1.977 (1977.0)
Custom length in CM	- - -

Spec	Phase stability vs bending ⁽¹⁾	Amplitude stability vs bending ⁽²⁾	Max VSWR	Max IL	Flexure life cycle ⁽³⁾
3GHz	±0.3° typ / ±0.5° max	±0.005dB typ / ±0.01dB max	1.12 : 1	≤ (0.0128dB/cm*Lcm)+0.15dB	≥ 100000
6GHz	±0.5° typ / ±0.75° max	±0.0075dB typ / ±0.015dB max	1.15 : 1	≤ (0.0189dB/cm*Lcm)+0.20dB	
12.4GHz	±0.75° typ / ±1.0° max	±0.01dB typ / ±0.02dB max	1.20 : 1	≤ (0.0293dB/cm*Lcm)+0.25dB	
18GHz	±1.0° typ / ±1.5° max	±0.015dB typ / ±0.03dB max	1.25 : 1	≤ (0.0361dB/cm*Lcm)+0.30dB	
26.5GHz	±1.5° typ / ±2.0° max	±0.02dB typ / ±0.04dB max	1.25 : 1	≤ (0.0450dB/cm*Lcm)+0.40dB	

Notes:

- Operating Temp.: -40°C / +105°C
- Static bend radius 5.1mm
- Dynamic bend radius 20mm
- RoHS Compliant

- (1) Per IEC 60966-1, section 8.6, method 1
- (2) Per IEC 60966-1, section 8.4
- (3) Per IEC 60966-1, section 9.3

				STANDARD		REV	-	UNIT	CM(INCH)	JYE BAO CO., LTD.	
				APPROVED				DATE		TAIPEI TAIWAN	
				CHECKED				DATE		DESCRIPTION	
				DRAWING				DATE		CABLE ASSEMBLY 3.5 JACK TO 3.5 NMD JACK	
				Albert				DATE		JYE BAO DRAWING NO.	
								DATE		PC80PC8N-52A-26.5GX XX	
4	U-3.5N-F	3.5 NMD JACK	1	EA	LENGTH TOLERANCE IS ±1.5% OR ±10MM, WHICHEVER IS GREATER.						
3	U-5002A	SLEEVE	2	EA							
2	5002A	CABLE	SEE TABLE L1	M							
1	U-3.5-F	3.5 JACK	1	EA							
NO.	PARTS NO.	DESCRIPTION	Q'TY	U/M							