

OSLT-N-F-50-6G

N Jack 50ohm Open Short Load Through 6GHz

50Ω

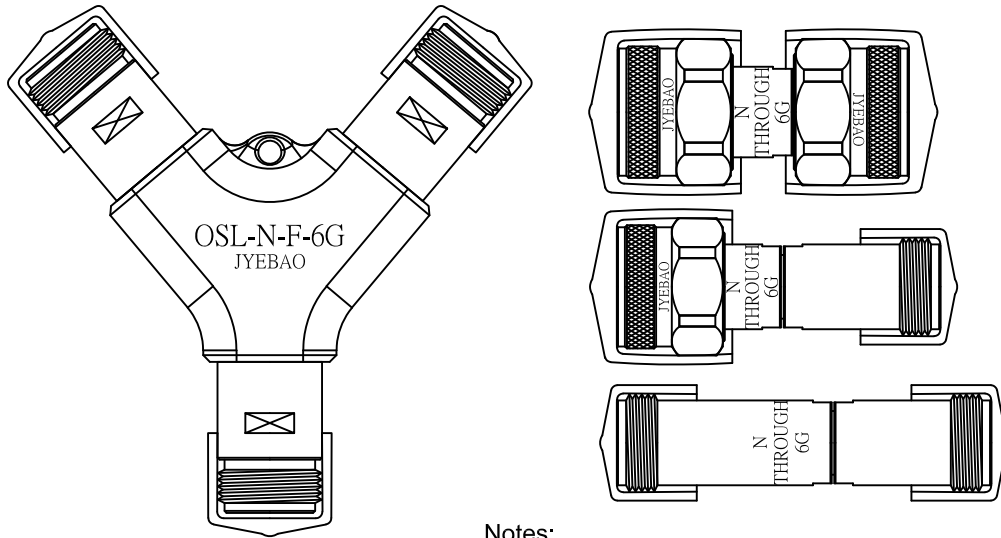

**Notes:**

1. Temperature range for optimal results: +20 °C to +26 °C
2. Storage temperature range: -20 °C to +75 °C
3. When not in use put on cap to keep connector clean
4. Return loss test results shipped along with goods

OPEN					SHORT				
Frequency Range	DC-6GHz				Frequency Range	DC-6GHz			
Impedance	50Ω				Impedance	50Ω			
Offset length	Agilent	Anritsu	Rohde&Schwarz		Offset length	Agilent	Anritsu	Rohde&Schwarz	
	42.70ps	12.81mm	12.81mm			42.70ps	12.81mm	12.81mm	
Capacitance	Agilent/Anritsu		Rohde&Schwarz		Inductance	Agilent/Anritsu		Rohde&Schwarz	
C0	(1E-15) F	-4.000	fF	-4.0000000	L0	(1E-12) H	0.000	pH	0.0000000
C1	(1E-27) F/Hz	600.000	fF/GHz	0.6000000	L1	(1E-24) H/Hz	0.000	pH/GHz	0.0000000
C2	(1E-36) F/Hz <sup>2</sup>	-10.000	fF/GHz <sup>2</sup>	-0.0100000	L2	(1E-33) H/Hz <sup>2</sup>	0.000	pH/GHz <sup>2</sup>	0.0000000
C3	(1E-45) F/Hz <sup>3</sup>	0.450	fF/GHz <sup>3</sup>	0.0004500	L3	(1E-42) H/Hz <sup>3</sup>	0.000	pH/GHz <sup>3</sup>	0.0000000
Phase Error					Phase Error				
DC-6GHz	≤1.5°				DC-6GHz	≤1.5°			
Return Loss					Return Loss				
DC-6GHz	≤0.10dB				DC-6GHz	≤0.10dB			

Load		Through Adaptor	
Frequency Range	DC-6GHz	Frequency Range	DC-6GHz
Impedance	50Ω	Impedance	50Ω
DC Resistance	50 ± 0.50Ω	Insertion Loss	≤0.2dB
Max Power	1W	Electrical Length	43.70+/-0.12mm
Return Loss DC-6GHz	≥42dB	Return Loss DC-6GHz	≥36dB

Parts	Material	Plating ( Micro-inch )
Housing	Aluminium	Anodized (Green)
Cap	PVC	
Body open/short/load	Brass	Tin-Zinc-Copper-Alloy 100 Over Copper 50
Contact pin open/short/load/ through adaptor	Beryllium Copper	Gold 4 Over Nickel Phosphorous Alloy 80 Over Copper 20
Dielectric load/ open/ through adaptor	PPO	
Coupling Nut & Body Adaptor	Stainless	Passivated

This part number complies with RoHS.

Notice: JYEBAO reserves the right to make modifications deemed appropriate.

# OSLT-N-F-50-6G

## OPEN return loss & phase error

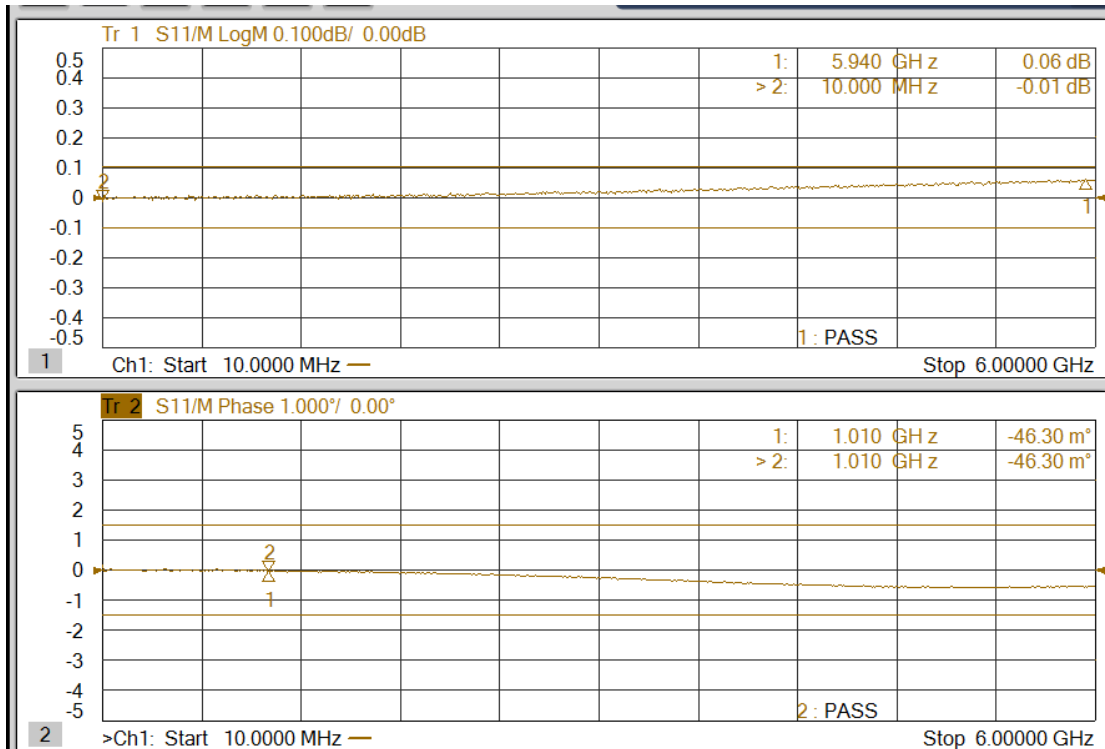

## SHORT return loss & phase error

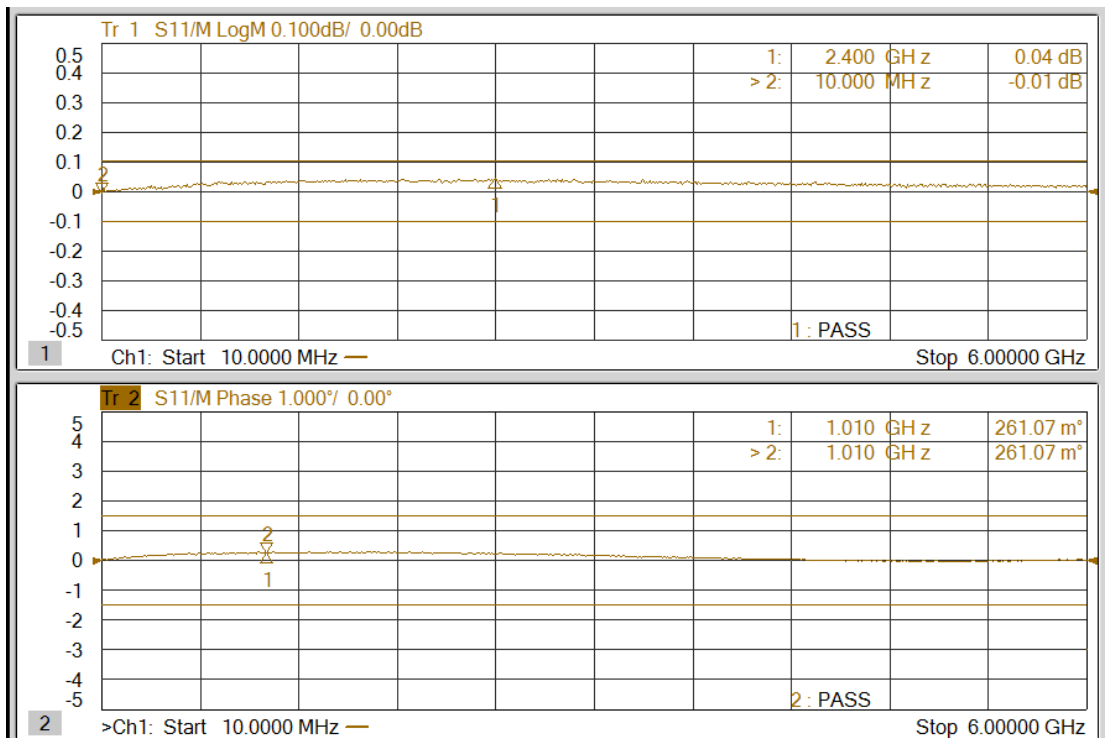

## LOAD return loss

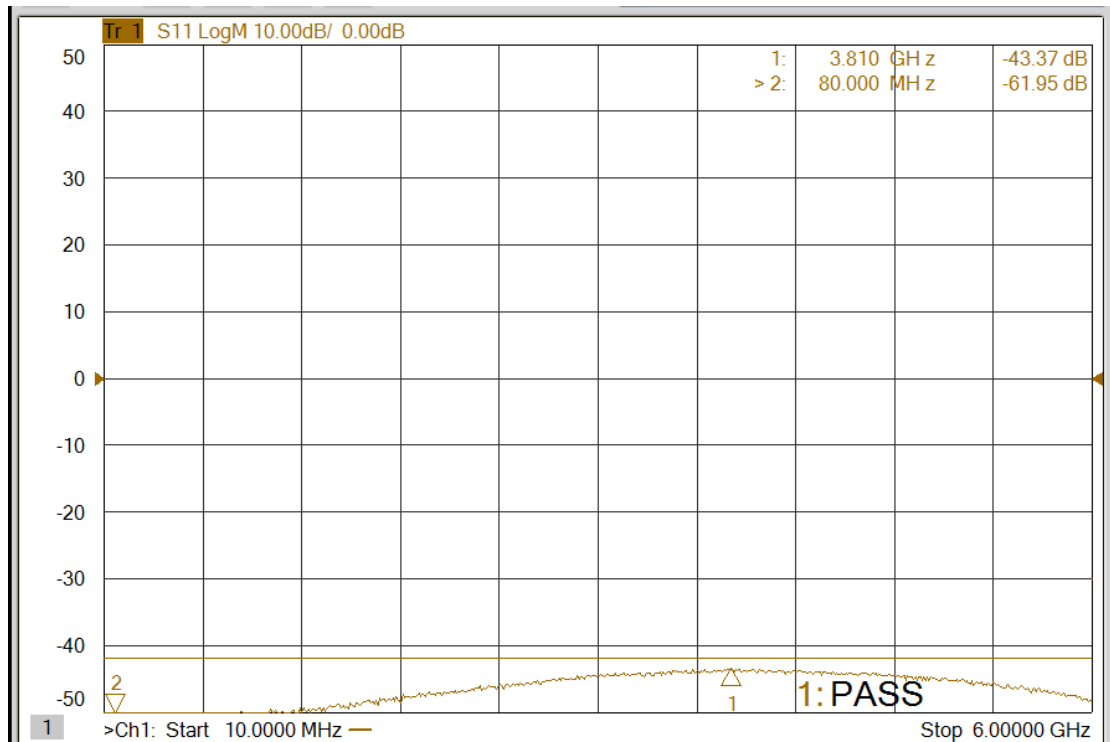

## Thru male-male insertion & return loss

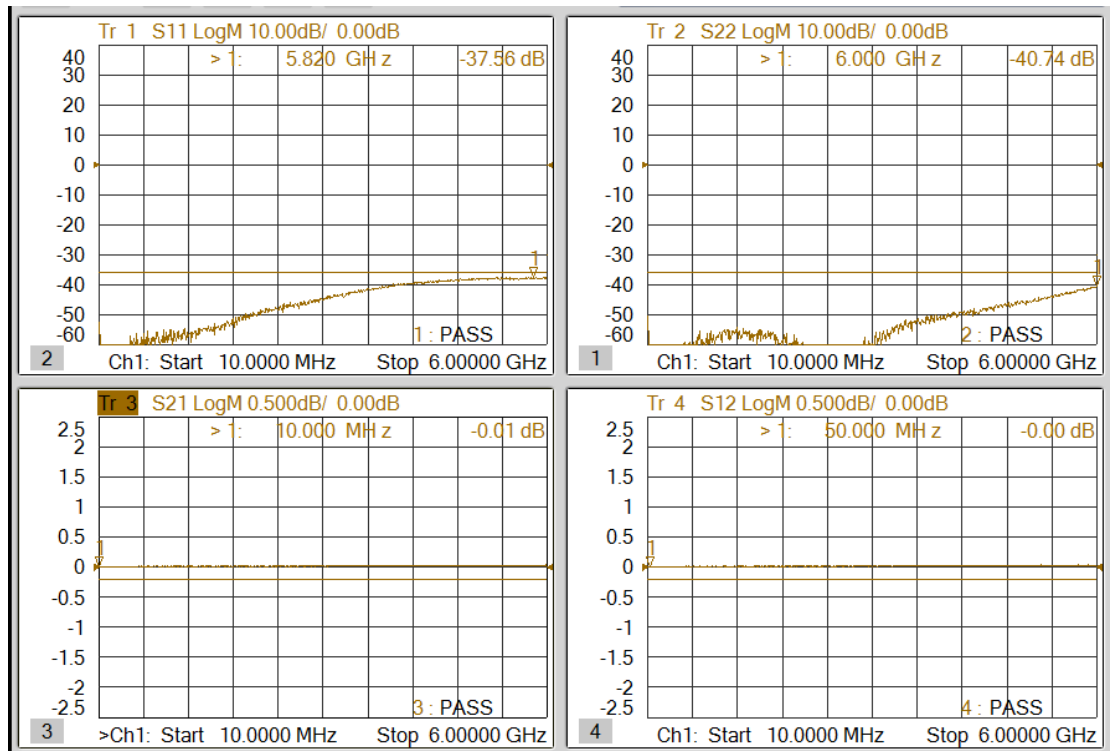

Thru male-male electrical length: 43.7mm

### Thru male-female insertion & return loss

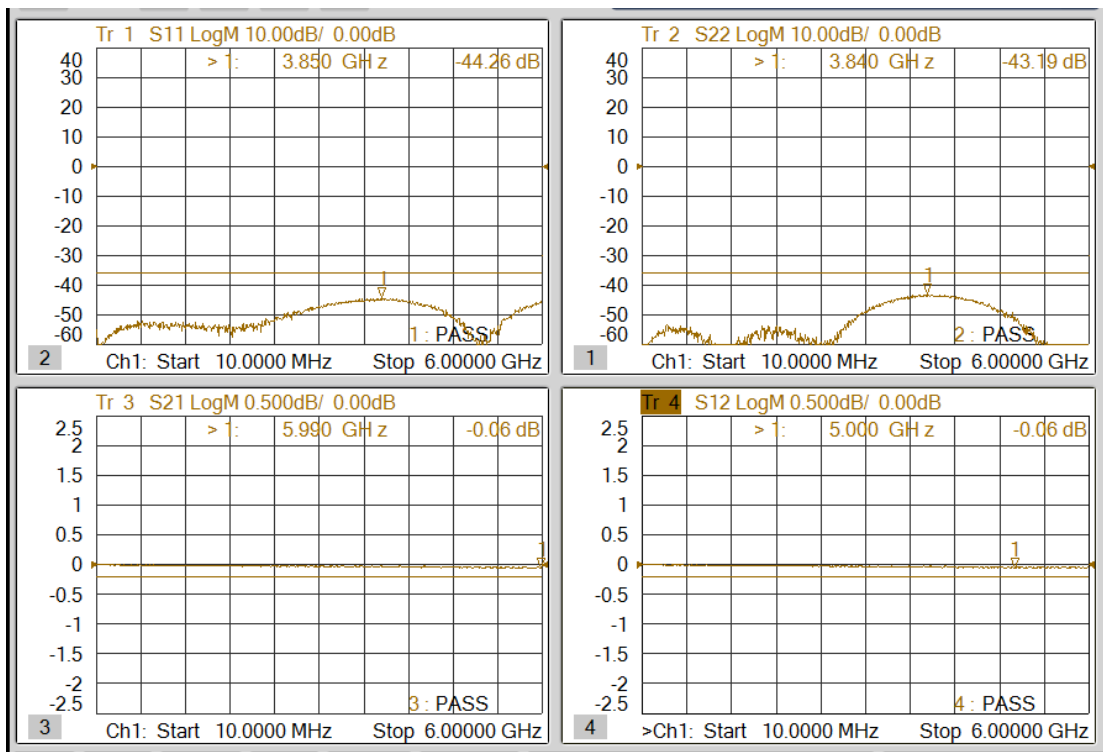

Thru male-female electrical length: 43.7mm

### Thru female-female insertion & return loss

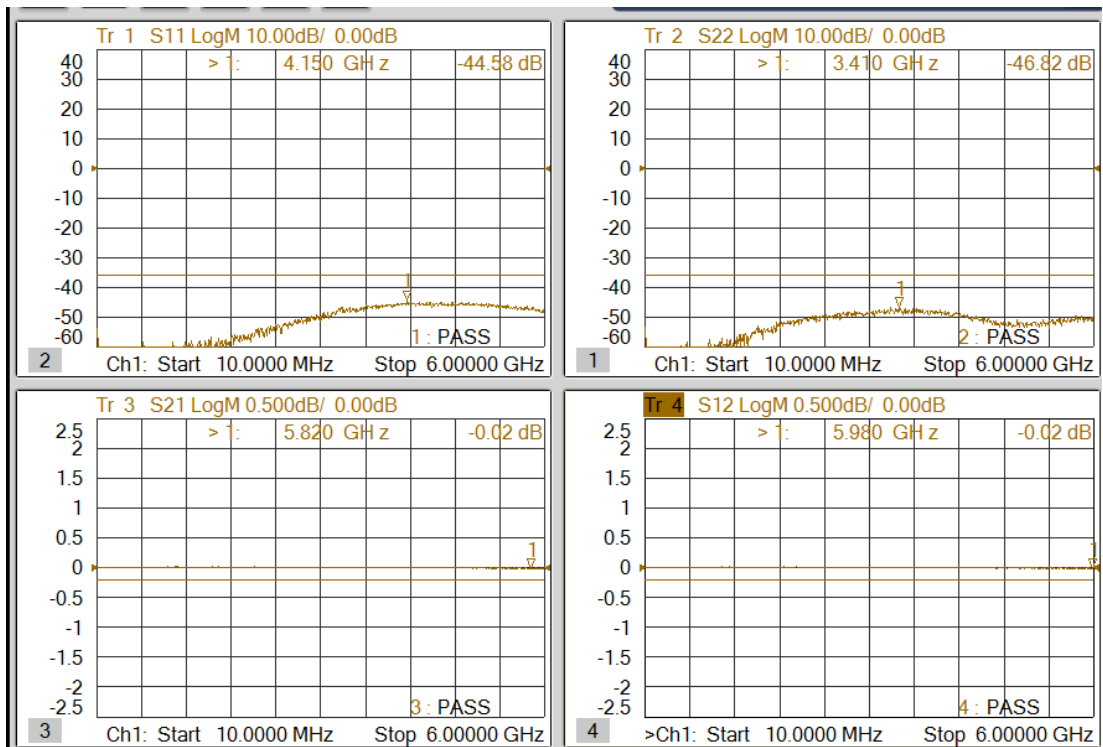

Thru female-female electrical length: 43.7mm