

OSL-N-M-50-4G

N Plug 50ohm Open Short Load 4GHz

50Ω

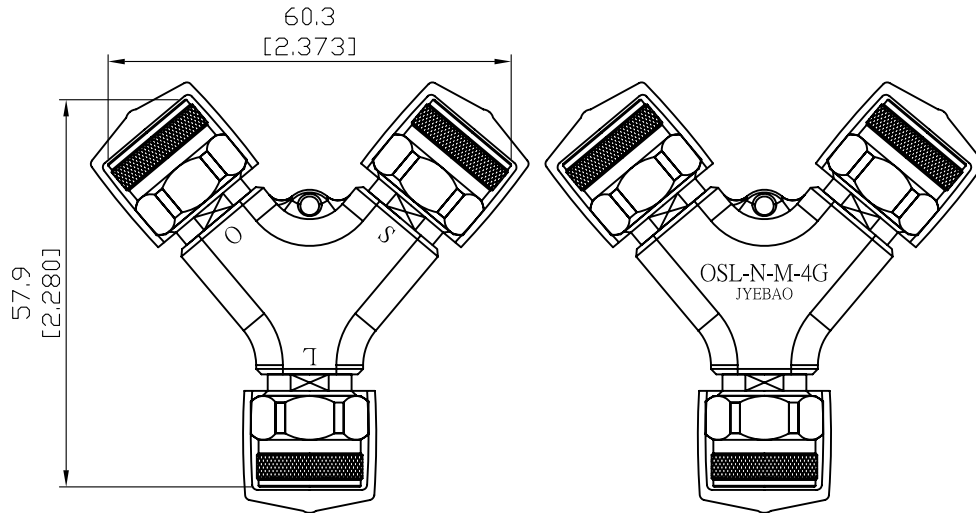

OPEN				SHORT					
Frequency Range	DC-4GHz			Frequency Range	DC-4GHz				
Impedance	50Ω			Impedance	50Ω				
Offset length	Agilent	Anritsu	Rohde&Schwarz	Offset length	Agilent	Anritsu	Rohde&Schwarz		
	59.44ps	17.83mm	17.83mm		59.44ps	17.83mm	17.83mm		
Capacitance	Agilent/Anritsu		Rohde&Schwarz	Inductance	Agilent/Anritsu		Rohde&Schwarz		
	C0	(1E-15) F	4.000 fF		4.0000000	L0	(1E-12) H	0.000 pH	0.0000000
C1	(1E-27) F/Hz	200.000	fF/GHz	0.2000000	L1	(1E-24) H/Hz	0.000 pH/GHz	0.0000000	
C2	(1E-36) F/Hz ²	0.000	fF/GHz ²	0.0000000	L2	(1E-33) H/Hz ²	0.000 pH/GHz ²	0.0000000	
C3	(1E-45) F/Hz ³	1.100	fF/GHz ³	0.0011000	L3	(1E-42) H/Hz ³	0.000 pH/GHz ³	0.0000000	
Phase Error	DC-4GHz			≤1.5°	Phase Error	DC-4GHz			≤1.5°
Return Loss	DC-4GHz			≤0.10dB	Return Loss	DC-4GHz			≤0.10dB

Load	
Frequency Range	DC-4Ghz
Impedance	50Ω
DC Resistance	50 ± 0.50Ω
Max Power	1W
Return Loss	DC-4GHz ≥45dB

Notes:

1. Temperature range for optimal results: +20 °C to +26 °C
2. Storage temperature range: -20 °C to +75°C
3. When not in use put on cap to keep connector clean
4. Return loss test results shipped along with goods

Parts	Material	Plating (Micro-inch)
Housing	Aluminium	Anodized (Green)
Cap	PVC	
Body open/short/load	Brass	Tin-Zinc-Copper-Alloy 100 Over Copper 50
Contact pin open/short/load	Beryllium Copper	Gold 4 Over Nickel Phosphorous Alloy 80 Over Copper 20
Dielectric open/ load	PPO	
Coupling Nut open/short/load	Stainless Steel	Passivated

This part number complies with RoHS.

Notice: JYEBAO reserves the right to make modifications deemed appropriate.

OSL-N-M-50-4G

OPEN return loss & phase error

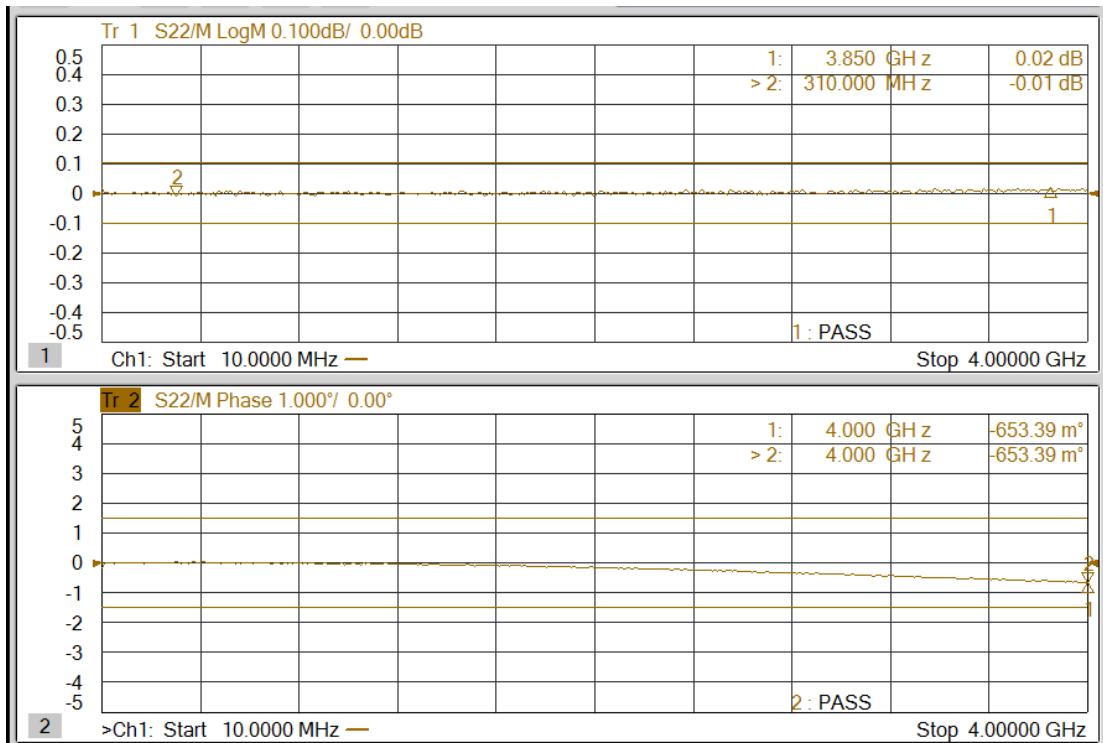

SHORT return loss & phase error

