

OS-SMA-F-6G

SMA Jack 50ohm Open Short 6GHz

50Ω

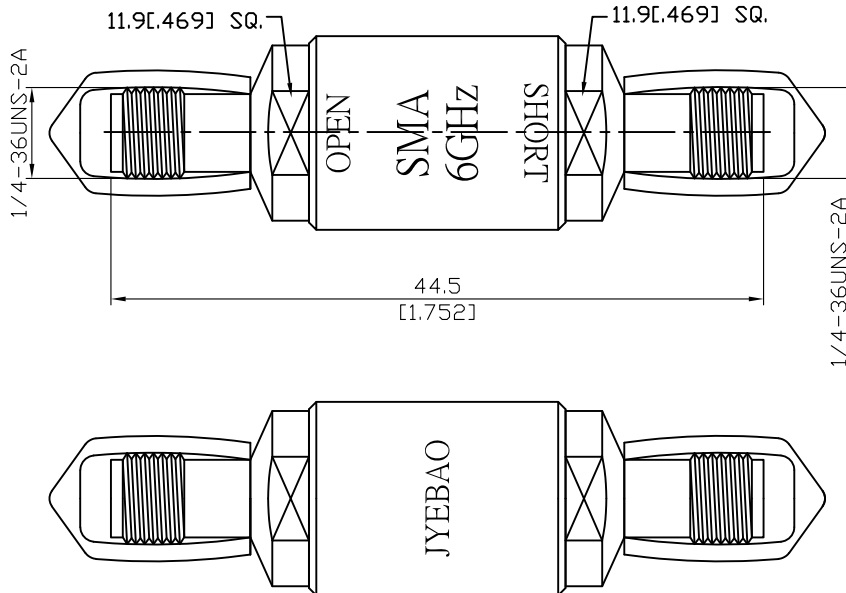

Notes:

1. Temperature range for optimal results: +20 °C to +26 °C
2. Storage temperature range: -20 °C to +75 °C
3. When not in use put on cap to keep connector clean
4. Return loss test results shipped along with goods (example below)

OPEN					SHORT				
Frequency Range	DC-6GHz				Frequency Range	DC-6GHz			
Impedance	50Ω				Impedance	50Ω			
Offset length	Agilent	Anritsu	Rohde&Schwarz		Offset length	Agilent	Anritsu	Rohde&Schwarz	
	16.70ps	5.01mm	5.01mm			16.70ps	5.01mm	5.01mm	
Capacitance	Agilent/Anritsu		Rohde&Schwarz		Inductance	Agilent/Anritsu		Rohde&Schwarz	
	C0	(1E-15) F	5.000	fF		5.0000000	L0	(1E-12) H	8.000
C1	(1E-27) F/Hz	0.000	fF/GHz	0.0000000	L1	(1E-24) H/Hz	-995.000	pH/GHz	-0.9950000
C2	(1E-36) F/Hz ²	1.500	fF/GHz ²	0.0015000	L2	(1E-33) H/Hz ²	33.000	pH/GHz ²	0.0330000
C3	(1E-45) F/Hz ³	0.100	fF/GHz ³	0.0001000	L3	(1E-42) H/Hz ³	-0.290	pH/GHz ³	-0.0002900
Phase Error					Phase Error				
DC-6GHz	≤1°				DC-6GHz	≤1°			
Return Loss					Return Loss				
DC-6GHz	≤0.10dB				DC-6GHz	≤0.10dB			

Parts	Material	Plating (Micro-inch)
Housing	Aluminium	Anodized (Green)
Cap	PVC	
Body open/short	Stainless Steel	Passivated
Contact pin open/short	Beryllium Copper	Gold 4 Over Nickel Phosphorous Alloy 80 Over Copper 20
Dielectric	Teflon	

This part number complies with RoHS.

Notice: JYEBAO reserves the right to make modifications deemed appropriate.

OS-SMA-F-6G

OPEN return loss & phase error

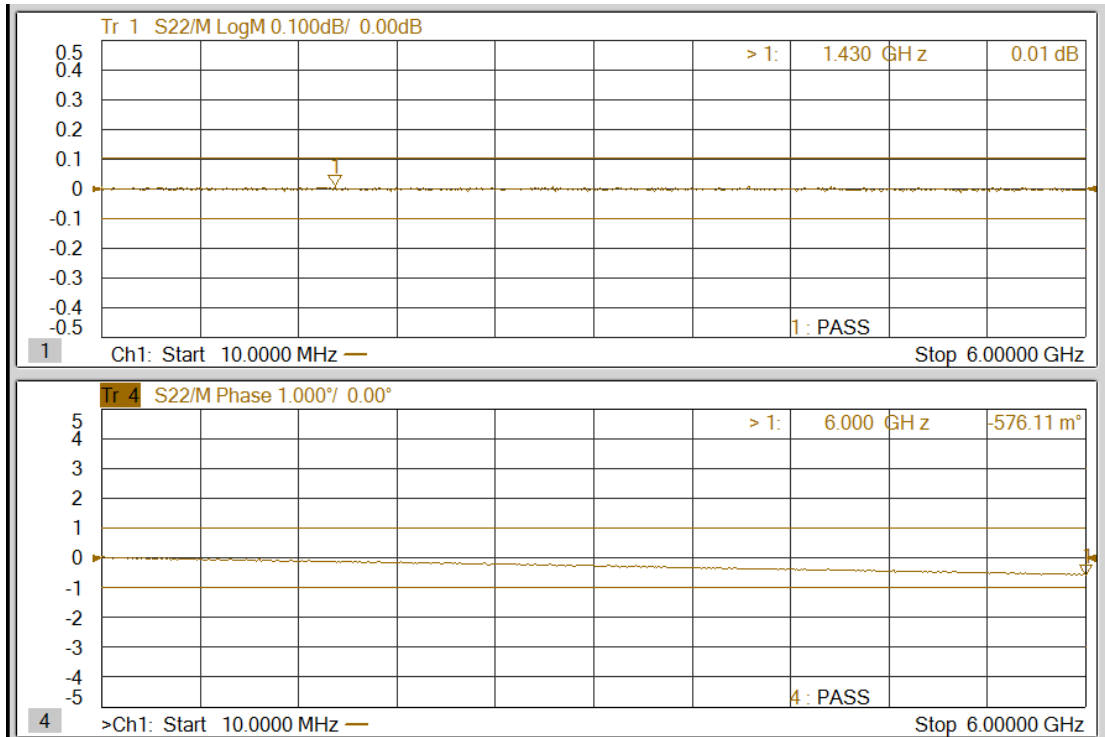

SHORT return loss & phase error

