

N864L9E-0000/NI

N Jack SQ 17.5mm 4 Hole Flange With Round Contact
(Φ1.24;L=3.2); PTFE L=9.5; IP67 Mated; 6GHz VSWR 1.2

50Ω

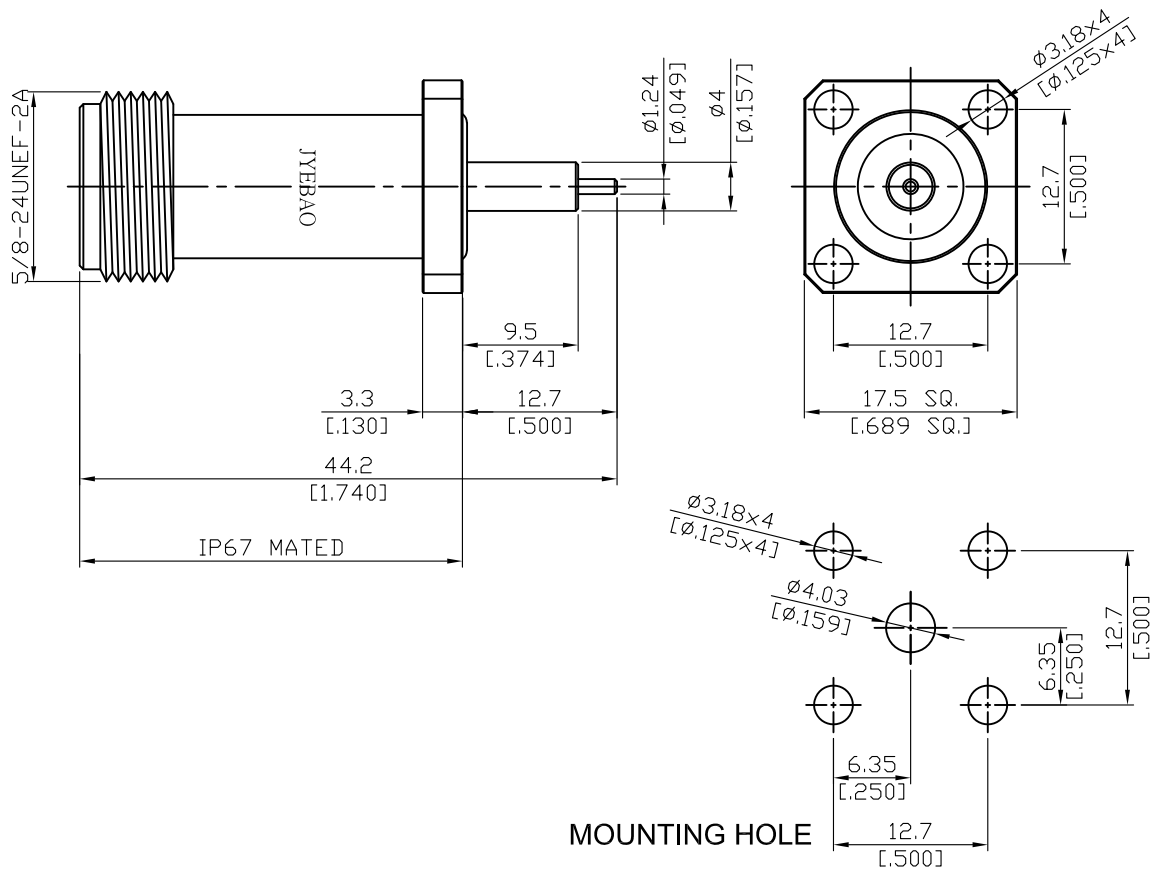

Parts	Material	Plating (Micro-inch)
Gasket	Silicone	
Contact Pin	Phosphor Bronze	Gold 4 Over Nickel-Phosphorus Alloy 80 Over Copper 20
Insulator	Teflon	
Body	Brass	Nickel 150 Over Copper 50

This part number complies with RoHS.

Notice: JYEBAO reserves the right to make modifications deemed appropriate.

N	N864L9E-0000/NI																		
<div style="border: 1px solid black; padding: 2px; margin-bottom: 5px;">Interface</div> MIL-STD-348B																			
<div style="border: 1px solid black; padding: 2px; margin-bottom: 5px;">Electrical Data</div> <table style="width: 100%; border-collapse: collapse;"> <tr> <td style="width: 60%;">Impedance</td> <td style="text-align: right;">50Ω</td> </tr> <tr> <td>Frequency range</td> <td style="text-align: right;">DC to 6GHz</td> </tr> <tr> <td>VSWR</td> <td style="text-align: right;">≤ 1.2 (DC to 6GHz)</td> </tr> <tr> <td>Insertion loss</td> <td style="text-align: right;">$\leq 0.05 \times \sqrt{f(\text{GHz})}$ dB</td> </tr> <tr> <td>Insulation resistance</td> <td style="text-align: right;">$\geq 5000\text{M}\Omega$</td> </tr> <tr> <td>Contact resistance inner conductor</td> <td style="text-align: right;">$\leq 1.5\text{m}\Omega$</td> </tr> <tr> <td>Contact resistance outer conductor</td> <td style="text-align: right;">$\leq 1\text{m}\Omega$</td> </tr> <tr> <td>Dielectric withstanding voltage (at sea level)</td> <td style="text-align: right;">2500 V rms</td> </tr> <tr> <td>Working voltage (at sea level)</td> <td style="text-align: right;">1000 V rms</td> </tr> </table>		Impedance	50Ω	Frequency range	DC to 6GHz	VSWR	≤ 1.2 (DC to 6GHz)	Insertion loss	$\leq 0.05 \times \sqrt{f(\text{GHz})}$ dB	Insulation resistance	$\geq 5000\text{M}\Omega$	Contact resistance inner conductor	$\leq 1.5\text{m}\Omega$	Contact resistance outer conductor	$\leq 1\text{m}\Omega$	Dielectric withstanding voltage (at sea level)	2500 V rms	Working voltage (at sea level)	1000 V rms
Impedance	50Ω																		
Frequency range	DC to 6GHz																		
VSWR	≤ 1.2 (DC to 6GHz)																		
Insertion loss	$\leq 0.05 \times \sqrt{f(\text{GHz})}$ dB																		
Insulation resistance	$\geq 5000\text{M}\Omega$																		
Contact resistance inner conductor	$\leq 1.5\text{m}\Omega$																		
Contact resistance outer conductor	$\leq 1\text{m}\Omega$																		
Dielectric withstanding voltage (at sea level)	2500 V rms																		
Working voltage (at sea level)	1000 V rms																		
<div style="border: 1px solid black; padding: 2px; margin-bottom: 5px;">Mechanical Data</div> <table style="width: 100%; border-collapse: collapse;"> <tr> <td style="width: 60%;">Recommended coupling nut torque</td> <td style="text-align: right;">6 to 10 inch lbs</td> </tr> <tr> <td>Coupling proof torque</td> <td style="text-align: right;">15 inch lbs</td> </tr> <tr> <td>Contact captivation-axial</td> <td style="text-align: right;">≥ 6.3 lbs</td> </tr> <tr> <td>Durability (mating)</td> <td style="text-align: right;">≥ 500</td> </tr> </table>		Recommended coupling nut torque	6 to 10 inch lbs	Coupling proof torque	15 inch lbs	Contact captivation-axial	≥ 6.3 lbs	Durability (mating)	≥ 500										
Recommended coupling nut torque	6 to 10 inch lbs																		
Coupling proof torque	15 inch lbs																		
Contact captivation-axial	≥ 6.3 lbs																		
Durability (mating)	≥ 500																		
<div style="border: 1px solid black; padding: 2px; margin-bottom: 5px;">Environmental Data</div> <table style="width: 100%; border-collapse: collapse;"> <tr> <td style="width: 60%;">Temperature range</td> <td style="text-align: right;">-65°C to +165°C</td> </tr> <tr> <td>Thermal shock</td> <td style="text-align: right;">MIL-STD-202, Method 107, Condition B</td> </tr> <tr> <td>Moisture resistance</td> <td style="text-align: right;">MIL-STD-202, Method 106</td> </tr> <tr> <td>Corrosion</td> <td style="text-align: right;">MIL-STD-202, Method 101, Condition B</td> </tr> <tr> <td>RoHS</td> <td style="text-align: right;">Compliant</td> </tr> </table>		Temperature range	-65°C to +165°C	Thermal shock	MIL-STD-202, Method 107, Condition B	Moisture resistance	MIL-STD-202, Method 106	Corrosion	MIL-STD-202, Method 101, Condition B	RoHS	Compliant								
Temperature range	-65°C to +165°C																		
Thermal shock	MIL-STD-202, Method 107, Condition B																		
Moisture resistance	MIL-STD-202, Method 106																		
Corrosion	MIL-STD-202, Method 101, Condition B																		
RoHS	Compliant																		
<div style="border: 1px solid black; padding: 2px; margin-bottom: 5px;">Tooling</div>																			

Notice: JYEBAO reserves the right to make modifications deemed appropriate.

