

N864A-9000	N Jack SQ 25.4mm 4 Hole Flange Right Angle With Solder Cup Contact; 12.4GHz VSWR 1.2	50Ω
------------	---	-----

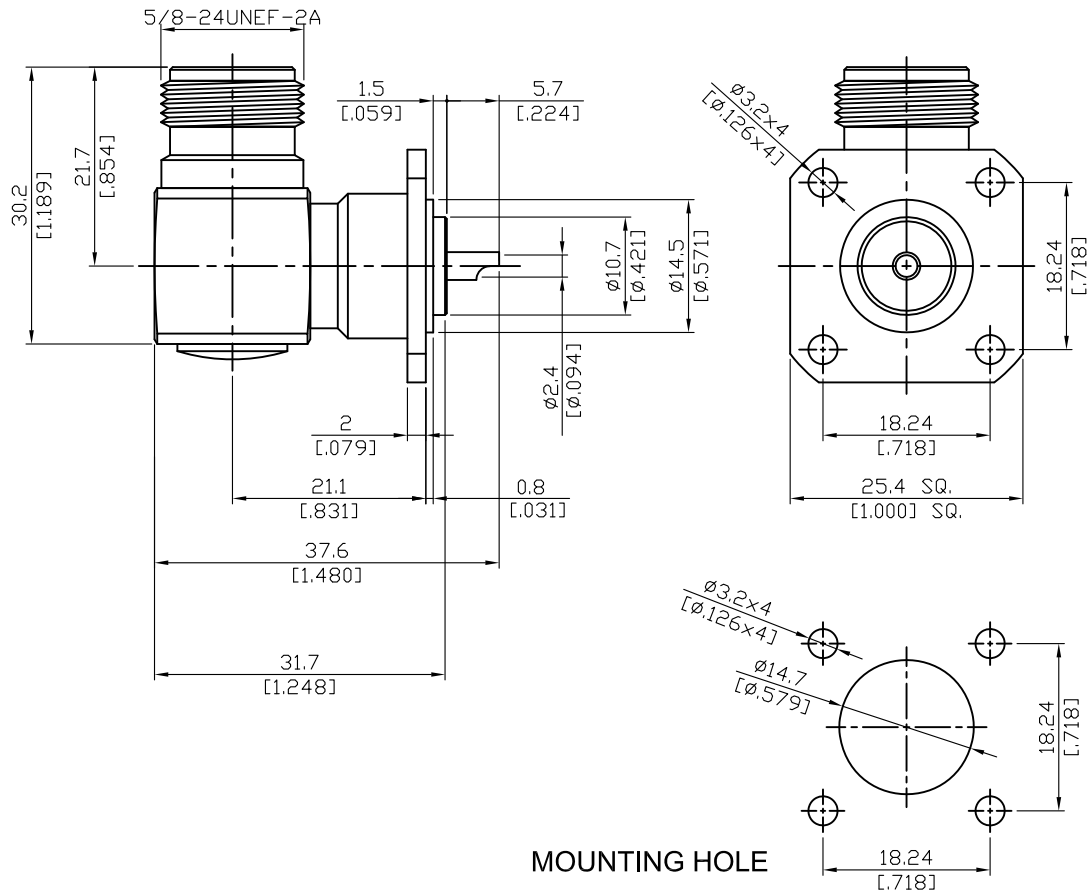

Parts	Material	Plating (Micro-inch)
Nut	Brass	Tin-Zinc-Copper-Alloy 100 Over Copper 50
Contact Pin	Brass	Gold 4 Over Nickel-Phosphorus Alloy 80 Over Copper 20
Insulator	Teflon	
Contact Pin	Beryllium Copper	Gold 4 Over Nickel-Phosphorus Alloy 80 Over Copper 20
Insulator	Teflon	
Body	Brass	Tin-Zinc-Copper-Alloy 100 Over Copper 50

--	--

This part number complies with RoHS.

Notice: JYEBAO reserves the right to make modifications deemed appropriate.

N	N864A-9000																		
<div data-bbox="167 344 568 394" style="border: 1px solid black; padding: 2px;">Interface</div> <p>MIL-STD-348B</p>																			
<div data-bbox="167 510 568 560" style="border: 1px solid black; padding: 2px;">Electrical Data</div> <table border="0" style="width: 100%;"> <tr> <td style="width: 50%;">Impedance</td> <td style="width: 50%;">50Ω</td> </tr> <tr> <td>Frequency range</td> <td>DC to 12.4GHz</td> </tr> <tr> <td>VSWR</td> <td>≤ 1.2 (DC to 12.4GHz)</td> </tr> <tr> <td>Insertion loss</td> <td>≤ 0.05 x √f(GHz) dB</td> </tr> <tr> <td>Insulation resistance</td> <td>≥ 5000MΩ</td> </tr> <tr> <td>Contact resistance inner conductor</td> <td>≤ 1.5mΩ</td> </tr> <tr> <td>Contact resistance outer conductor</td> <td>≤ 1mΩ</td> </tr> <tr> <td>Dielectric withstanding voltage (at sea level)</td> <td>2500 V rms</td> </tr> <tr> <td>Working voltage (at sea level)</td> <td>1000 V rms</td> </tr> </table>		Impedance	50Ω	Frequency range	DC to 12.4GHz	VSWR	≤ 1.2 (DC to 12.4GHz)	Insertion loss	≤ 0.05 x √f(GHz) dB	Insulation resistance	≥ 5000MΩ	Contact resistance inner conductor	≤ 1.5mΩ	Contact resistance outer conductor	≤ 1mΩ	Dielectric withstanding voltage (at sea level)	2500 V rms	Working voltage (at sea level)	1000 V rms
Impedance	50Ω																		
Frequency range	DC to 12.4GHz																		
VSWR	≤ 1.2 (DC to 12.4GHz)																		
Insertion loss	≤ 0.05 x √f(GHz) dB																		
Insulation resistance	≥ 5000MΩ																		
Contact resistance inner conductor	≤ 1.5mΩ																		
Contact resistance outer conductor	≤ 1mΩ																		
Dielectric withstanding voltage (at sea level)	2500 V rms																		
Working voltage (at sea level)	1000 V rms																		
<div data-bbox="167 1055 568 1104" style="border: 1px solid black; padding: 2px;">Mechanical Data</div> <table border="0" style="width: 100%;"> <tr> <td style="width: 50%;">Recommended coupling nut torque</td> <td style="width: 50%;">6 to 10 inch lbs</td> </tr> <tr> <td>Coupling proof torque</td> <td>15 inch lbs</td> </tr> <tr> <td>Contact captivation-axial</td> <td>≥ 6.3 lbs</td> </tr> <tr> <td>Durability (mating)</td> <td>≥ 500</td> </tr> </table>		Recommended coupling nut torque	6 to 10 inch lbs	Coupling proof torque	15 inch lbs	Contact captivation-axial	≥ 6.3 lbs	Durability (mating)	≥ 500										
Recommended coupling nut torque	6 to 10 inch lbs																		
Coupling proof torque	15 inch lbs																		
Contact captivation-axial	≥ 6.3 lbs																		
Durability (mating)	≥ 500																		
<div data-bbox="167 1411 568 1460" style="border: 1px solid black; padding: 2px;">Environmental Data</div> <table border="0" style="width: 100%;"> <tr> <td style="width: 50%;">Temperature range</td> <td style="width: 50%;">-65°C to +165°C</td> </tr> <tr> <td>Thermal shock</td> <td>MIL-STD-202, Method 107, Condition B</td> </tr> <tr> <td>Moisture resistance</td> <td>MIL-STD-202, Method 106</td> </tr> <tr> <td>Corrosion</td> <td>MIL-STD-202, Method 101, Condition B</td> </tr> <tr> <td>RoHS</td> <td>Compliant</td> </tr> </table>		Temperature range	-65°C to +165°C	Thermal shock	MIL-STD-202, Method 107, Condition B	Moisture resistance	MIL-STD-202, Method 106	Corrosion	MIL-STD-202, Method 101, Condition B	RoHS	Compliant								
Temperature range	-65°C to +165°C																		
Thermal shock	MIL-STD-202, Method 107, Condition B																		
Moisture resistance	MIL-STD-202, Method 106																		
Corrosion	MIL-STD-202, Method 101, Condition B																		
RoHS	Compliant																		
<div data-bbox="167 1762 568 1812" style="border: 1px solid black; padding: 2px;">Tooling</div>																			

Notice: JYEBAO reserves the right to make modifications deemed appropriate.

N864A-9000

S11

