

N8505C-0000/HS

**N Jack Bulkhead With Solder Cup
Contact; Hermetic; 11GHz VSWR 1.2**

50Ω

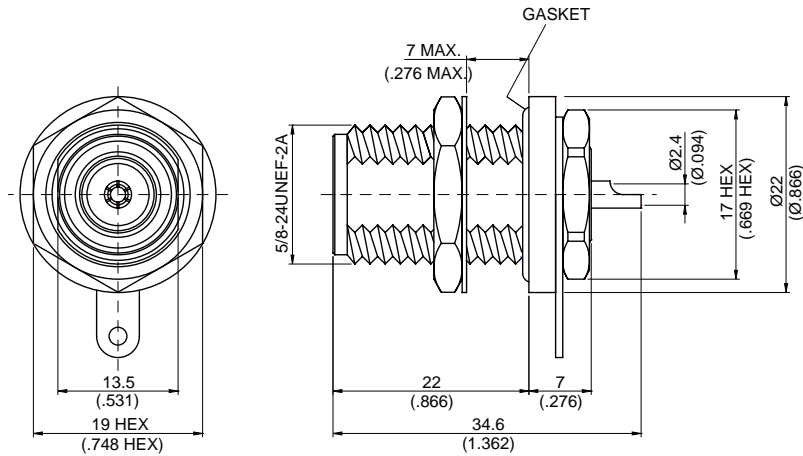

MOUNTING HOLE

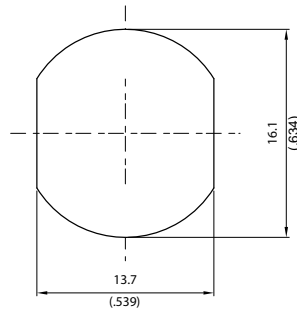

Hermetic 1×10^{-6} cc/sec at 1atm of helium

Parts	Material	Plating (Micro-inch)
Hex Nut	Brass	Tin-Zinc-Copper-Alloy 100 Over Copper 50
Lock Washer	Brass	Tin-Zinc-Copper-Alloy 100 Over Copper 50
Gasket	Silicone	
Solder Tag	Brass	Tin-Zinc-Copper-Alloy 100 Over Copper 50
Contact Pin	Beryllium Copper	Gold 4 Over Nickel-Phosphorus Alloy 80 Over Copper 20
Insulator	Teflon	
Body	Brass	Tin-Zinc-Copper-Alloy 100 Over Copper 50

This part number complies with RoHS.

Notice: JYEBAC reserves the right to make modifications deemed appropriate.

N	N8505C-0000/HS																		
<div data-bbox="167 344 568 392" style="border: 1px solid black; padding: 2px;">Interface</div> <p>MIL-STD-348B</p>																			
<div data-bbox="167 510 568 557" style="border: 1px solid black; padding: 2px;">Electrical Data</div> <table border="0" style="width: 100%;"> <tr> <td style="width: 50%;">Impedance</td> <td style="width: 50%;">50Ω</td> </tr> <tr> <td>Frequency range</td> <td>DC to 11GHz</td> </tr> <tr> <td>VSWR</td> <td>≦ 1.2 (DC to 11GHz)</td> </tr> <tr> <td>Insertion loss</td> <td>≦ 0.05 x √f(GHz) dB</td> </tr> <tr> <td>Insulation resistance</td> <td>≧ 5000MΩ</td> </tr> <tr> <td>Contact resistance inner conductor</td> <td>≦ 1.5mΩ</td> </tr> <tr> <td>Contact resistance outer conductor</td> <td>≦ 1mΩ</td> </tr> <tr> <td>Dielectric withstanding voltage (at sea level)</td> <td>2500 V rms</td> </tr> <tr> <td>Working voltage (at sea level)</td> <td>1000 V rms</td> </tr> </table>		Impedance	50Ω	Frequency range	DC to 11GHz	VSWR	≦ 1.2 (DC to 11GHz)	Insertion loss	≦ 0.05 x √f(GHz) dB	Insulation resistance	≧ 5000MΩ	Contact resistance inner conductor	≦ 1.5mΩ	Contact resistance outer conductor	≦ 1mΩ	Dielectric withstanding voltage (at sea level)	2500 V rms	Working voltage (at sea level)	1000 V rms
Impedance	50Ω																		
Frequency range	DC to 11GHz																		
VSWR	≦ 1.2 (DC to 11GHz)																		
Insertion loss	≦ 0.05 x √f(GHz) dB																		
Insulation resistance	≧ 5000MΩ																		
Contact resistance inner conductor	≦ 1.5mΩ																		
Contact resistance outer conductor	≦ 1mΩ																		
Dielectric withstanding voltage (at sea level)	2500 V rms																		
Working voltage (at sea level)	1000 V rms																		
<div data-bbox="167 1055 568 1102" style="border: 1px solid black; padding: 2px;">Mechanical Data</div> <table border="0" style="width: 100%;"> <tr> <td style="width: 50%;">Recommended coupling nut torque</td> <td style="width: 50%;">6 to 10 inch lbs</td> </tr> <tr> <td>Coupling proof torque</td> <td>15 inch lbs</td> </tr> <tr> <td>Contact captivation-axial</td> <td>≧ 6.3 lbs</td> </tr> <tr> <td>Durability (mating)</td> <td>≧ 500</td> </tr> </table>		Recommended coupling nut torque	6 to 10 inch lbs	Coupling proof torque	15 inch lbs	Contact captivation-axial	≧ 6.3 lbs	Durability (mating)	≧ 500										
Recommended coupling nut torque	6 to 10 inch lbs																		
Coupling proof torque	15 inch lbs																		
Contact captivation-axial	≧ 6.3 lbs																		
Durability (mating)	≧ 500																		
<div data-bbox="167 1411 568 1458" style="border: 1px solid black; padding: 2px;">Environmental Data</div> <table border="0" style="width: 100%;"> <tr> <td style="width: 50%;">Temperature range</td> <td style="width: 50%;">-65°C to +165°C</td> </tr> <tr> <td>Thermal shock</td> <td>MIL-STD-202, Method 107, Condition B</td> </tr> <tr> <td>Moisture resistance</td> <td>MIL-STD-202, Method 106</td> </tr> <tr> <td>Corrosion</td> <td>MIL-STD-202, Method 101, Condition B</td> </tr> <tr> <td>RoHS</td> <td>Compliant</td> </tr> </table>		Temperature range	-65°C to +165°C	Thermal shock	MIL-STD-202, Method 107, Condition B	Moisture resistance	MIL-STD-202, Method 106	Corrosion	MIL-STD-202, Method 101, Condition B	RoHS	Compliant								
Temperature range	-65°C to +165°C																		
Thermal shock	MIL-STD-202, Method 107, Condition B																		
Moisture resistance	MIL-STD-202, Method 106																		
Corrosion	MIL-STD-202, Method 101, Condition B																		
RoHS	Compliant																		
<div data-bbox="167 1762 568 1809" style="border: 1px solid black; padding: 2px;">Tooling</div>																			

Notice: JYEBAO reserves the right to make modifications deemed appropriate.

N8505C-0000/HS

S11

