

**N364AA-0075**      **N Plug SQ 25.4mm 4 Hole Flange**      **75Ω**  
**With Solder Cup Contact; 4GHz VSWR 1.25**

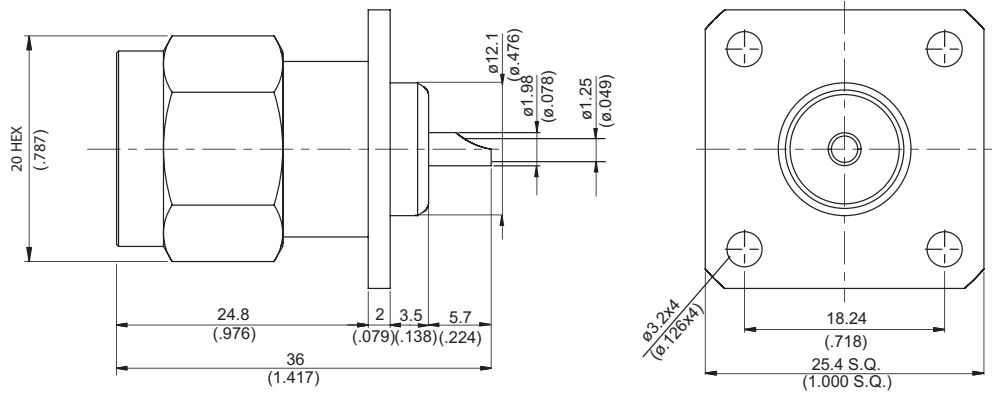

**MOUNTING HOLE :**

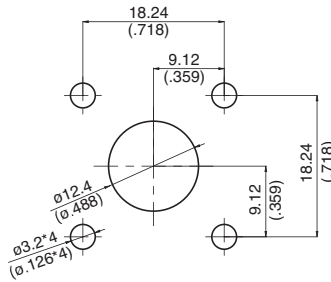

Parts	Material	Plating (Micro-inch)
Center Pin	Brass	Gold 4 Over Nickel-Phosphorus Alloy 80 Over Copper 20
Retainer Ring	Brass	Tin-Zinc-Copper-Alloy 100 Over Copper 50
Gasket	Silicon	
Contact Body	Brass	Tin-Zinc-Copper-Alloy 100 Over Copper 50
Insulator	Teflon	
Body	Brass	Tin-Zinc-Copper-Alloy 100 Over Copper 50
Coupling Nut	Brass	Tin-Zinc-Copper-Alloy 100 Over Copper 50

**This part number complies with RoHS.**

**Notice: JYEBAO reserves the right to make modifications deemed appropriate.**

N	N364AA-0075																				
<div style="border: 1px solid black; padding: 2px; margin-bottom: 5px;">Interface</div> <p>MIL-STD-348B</p>																					
<div style="border: 1px solid black; padding: 2px; margin-bottom: 5px;">Electrical Data</div> <table style="width: 100%; border-collapse: collapse;"> <tr> <td style="width: 50%;">Impedance</td> <td style="width: 50%;">75Ω</td> </tr> <tr> <td>Frequency range</td> <td>DC to 4GHz</td> </tr> <tr> <td>VSWR</td> <td>≤ 1.25 (DC to 4GHz)</td> </tr> <tr> <td>Insertion loss</td> <td>≤ 0.05 x √f(GHz) dB</td> </tr> <tr> <td>Insulation resistance</td> <td>≥ 5000MΩ</td> </tr> <tr> <td>Contact resistance inner conductor</td> <td>≤ 1mΩ</td> </tr> <tr> <td>Contact resistance outer conductor</td> <td>≤ 1mΩ</td> </tr> <tr> <td>Dielectric withstanding voltage (at sea level)</td> <td>2500 V rms</td> </tr> <tr> <td>Working voltage (at sea level)</td> <td>1000 V rms</td> </tr> <tr> <td>RF leakage</td> <td>≥ 128dB to 1GHz</td> </tr> </table>		Impedance	75Ω	Frequency range	DC to 4GHz	VSWR	≤ 1.25 (DC to 4GHz)	Insertion loss	≤ 0.05 x √f(GHz) dB	Insulation resistance	≥ 5000MΩ	Contact resistance inner conductor	≤ 1mΩ	Contact resistance outer conductor	≤ 1mΩ	Dielectric withstanding voltage (at sea level)	2500 V rms	Working voltage (at sea level)	1000 V rms	RF leakage	≥ 128dB to 1GHz
Impedance	75Ω																				
Frequency range	DC to 4GHz																				
VSWR	≤ 1.25 (DC to 4GHz)																				
Insertion loss	≤ 0.05 x √f(GHz) dB																				
Insulation resistance	≥ 5000MΩ																				
Contact resistance inner conductor	≤ 1mΩ																				
Contact resistance outer conductor	≤ 1mΩ																				
Dielectric withstanding voltage (at sea level)	2500 V rms																				
Working voltage (at sea level)	1000 V rms																				
RF leakage	≥ 128dB to 1GHz																				
<div style="border: 1px solid black; padding: 2px; margin-bottom: 5px;">Mechanical Data</div> <table style="width: 100%; border-collapse: collapse;"> <tr> <td style="width: 50%;">Recommended coupling nut torque</td> <td style="width: 50%;">6 to 10 inch lbs</td> </tr> <tr> <td>Coupling proof torque</td> <td>15 inch lbs</td> </tr> <tr> <td>Coupling nut retention force</td> <td>≥ 101.2 lbs</td> </tr> <tr> <td>Contact captivation-axial</td> <td>≥ 6.3 lbs</td> </tr> <tr> <td>Durability (mating)</td> <td>≥ 500</td> </tr> </table>		Recommended coupling nut torque	6 to 10 inch lbs	Coupling proof torque	15 inch lbs	Coupling nut retention force	≥ 101.2 lbs	Contact captivation-axial	≥ 6.3 lbs	Durability (mating)	≥ 500										
Recommended coupling nut torque	6 to 10 inch lbs																				
Coupling proof torque	15 inch lbs																				
Coupling nut retention force	≥ 101.2 lbs																				
Contact captivation-axial	≥ 6.3 lbs																				
Durability (mating)	≥ 500																				
<div style="border: 1px solid black; padding: 2px; margin-bottom: 5px;">Environmental Data</div> <table style="width: 100%; border-collapse: collapse;"> <tr> <td style="width: 50%;">Temperature range</td> <td style="width: 50%;">-65°C to +165°C</td> </tr> <tr> <td>Thermal shock</td> <td>MIL-STD-202, Method 107, Condition B</td> </tr> <tr> <td>Moisture resistance</td> <td>MIL-STD-202, Method 106</td> </tr> <tr> <td>Corrosion</td> <td>MIL-STD-202, Method 101, Condition B</td> </tr> <tr> <td>RoHS</td> <td>Compliant</td> </tr> </table>		Temperature range	-65°C to +165°C	Thermal shock	MIL-STD-202, Method 107, Condition B	Moisture resistance	MIL-STD-202, Method 106	Corrosion	MIL-STD-202, Method 101, Condition B	RoHS	Compliant										
Temperature range	-65°C to +165°C																				
Thermal shock	MIL-STD-202, Method 107, Condition B																				
Moisture resistance	MIL-STD-202, Method 106																				
Corrosion	MIL-STD-202, Method 101, Condition B																				
RoHS	Compliant																				
<div style="border: 1px solid black; padding: 2px; margin-bottom: 5px;">Tooling</div>																					

Notice: JYEBAO reserves the right to make modifications deemed appropriate.

# N364AA-0075

S11

