

NO.	COMPONENTS	IMPEDANCE
1	N MALE	50 OHM
2	5002A	50 OHM
3	SLEEVE	
4	3.5 NMD FEMALE	50 OHM

REVISION			
REV.	DESCRIPTON	DATE	APPROVED
-	INITIAL RELEASE	2021/01/10	

N MALE

3.5 NMD FEMALE

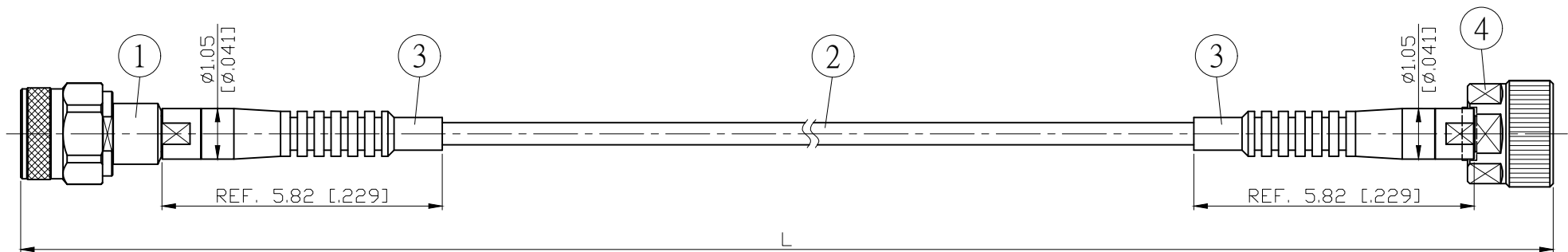

L CM (INCH)	L1 M (MM)
50 (19.685)	0.462 (462.0)
100 (39.370)	0.962 (962.0)
150 (59.055)	1.462 (1462.0)
200 (78.740)	1.962 (1962.0)
Custom length in CM	- - -

Spec	Phase stability vs bending ⁽¹⁾	Amplitude stability vs bending ⁽²⁾	Max VSWR	Max IL	Flexure life cycle ⁽³⁾
3GHz	±0.3° typ / ±0.5° max	±0.005dB typ / ±0.01dB max	1.12 : 1	≤ (0.0128dB/cm*Lcm)+0.15dB	≥ 100000
6GHz	±0.5° typ / ±0.75° max	±0.0075dB typ / ±0.015dB max	1.15 : 1	≤ (0.0189dB/cm*Lcm)+0.20dB	
12.4GHz	±0.75° typ / ±1.0° max	±0.01dB typ / ±0.02dB max	1.20 : 1	≤ (0.0293dB/cm*Lcm)+0.25dB	
18GHz	±1.0° typ / ±1.5° max	±0.015dB typ / ±0.03dB max	1.25 : 1	≤ (0.0361dB/cm*Lcm)+0.30dB	

Notes:

1. Operating Temp.: -40°C / +105°C
2. Static bend radius 5.1mm
3. Dynamic bend radius 20mm
4. RoHS Compliant

- (1) Per IEC 60966-1, section 8.6, method 1
- (2) Per IEC 60966-1, section 8.4
- (3) Per IEC 60966-1, section 9.3

NO.	PARTS NO.	DESCRIPTION	Q'TY	U/M	LENGTH TOLERANCE IS ±1.5% OR ±10MM, WHICHEVER IS GREATER.	STANDARD	REV	UNIT	JYE BAO CO., LTD. TAIPEI TAIWAN
4	U-3.5N-F	3.5 NMD JACK	1	EA		APPROVED	-	CM(INCH)	
3	U-5002A	SLEEVE	2	EA		CHECKED		DATE	
2	5002A	CABLE	SEE TABLE L1	M		DRAWING		DATE	
1	U-N-M	N PLUG	1	EA		<i>Albert</i>		DATE	DESCRIPTION CABLE ASSEMBLY N PLUG TO 3.5 NMD JACK
									JYE BAO DRAWING NO. N30PC8N-52A-18GXXX