

K8F46C-GA15

2.92mm Field Replaceable Jack,  
SQ 12.7mm (.500inch) 4 Hole Flange With EMI Gasket,  
Accepts  $\Phi 0.38$ mm (.015inch) Pin, 40GHz VSWR 1.15

50 $\Omega$

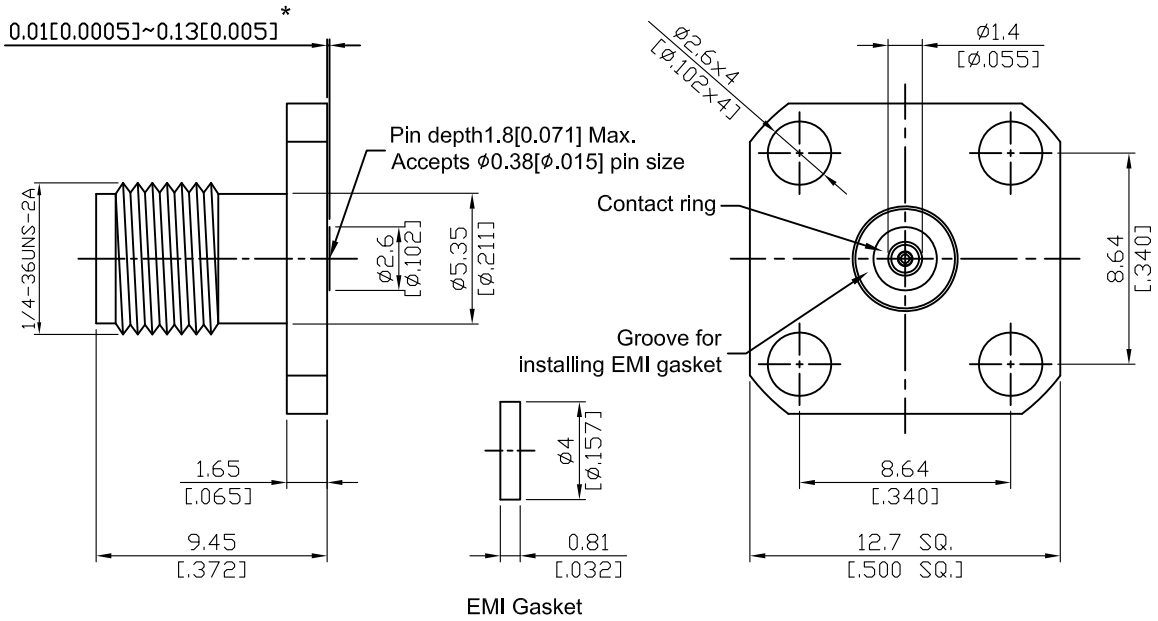

\*360° Raised Metal Contact Ring

Parts	Material	Plating ( Micro-inch )
Body	Stainless Steel	Passivated
Insulator	PEI	
Contact Pin	Beryllium Copper	Gold 4 Over Nickel-Phosphorus Alloy 80 Over Copper 20
Contact Ring	Stainless Steel	Passivated
EMI Gasket	Conductive Silicone Elastomers	

This part number complies with RoHS.

Notice: JYEBAO reserves the right to make modifications deemed appropriate.

K	K8F46C-GA15
<div data-bbox="113 327 513 376" style="border: 1px solid black; padding: 2px;">Interface</div> <p>MIL-STD-348B</p> <p>Mechanically compatible with 3.5 &amp; SMA</p>	
<div data-bbox="113 490 513 539" style="border: 1px solid black; padding: 2px;">Electrical Data</div> <p>Impedance 50Ω</p> <p>Frequency range DC to 40GHz</p> <p>VSWR <math>\leq 1.15</math> (DC to 40GHz)</p> <p>Insertion loss <math>\leq 0.04 \times \sqrt{f(\text{GHz})}</math> dB</p> <p>Insulation resistance <math>\geq 5000\text{M}\Omega</math></p> <p>Contact resistance inner conductor <math>\leq 3\text{m}\Omega</math></p> <p>Contact resistance outer conductor <math>\leq 2\text{m}\Omega</math></p> <p>Dielectric withstanding voltage (at sea level) 750 V rms</p> <p>Working Voltage (at sea level) 250 V rms</p> <p>RF leakage <math>\geq 100\text{dB}</math> to 1GHz</p>	
<div data-bbox="113 1084 513 1133" style="border: 1px solid black; padding: 2px;">Mechanical Data</div> <p>Recommended coupling nut torque 11.47 inch lbs</p> <p>Coupling proof torque 15 inch lbs</p> <p>Contact Captivation-axial <math>\geq 4.9</math> lbs</p> <p>Durability (mating) <math>\geq 500</math></p>	
<div data-bbox="113 1391 513 1440" style="border: 1px solid black; padding: 2px;">Environmental Data</div> <p>Temperature range -40°C to +150°C</p> <p>Thermal shock MIL-STD-202, Method 107, Condition B</p> <p>Moisture resistance MIL-STD-202, Method 206</p> <p>Corrosion MIL-STD-202, Method 101, Condition B</p> <p>RoHS Compliant</p>	
<div data-bbox="113 1744 513 1794" style="border: 1px solid black; padding: 2px;">Accessories</div> <p>Hermetic seal FR015-SEAL1; SEAL.015</p> <p>Launch pin &amp; Dielectric transition FR015-LAUNCH1; FR015-LAUNCH2</p> <p>Tab pin &amp; Dielectric transition FR015-TAB2; FR015-TAB3</p> <p>Tab pin FR015-TAB1</p>	

Notice: JYEBAO reserves the right to make modifications deemed appropriate.

## Recommended Launch Hole Dimensions :

### 1. Using Hermetic seals

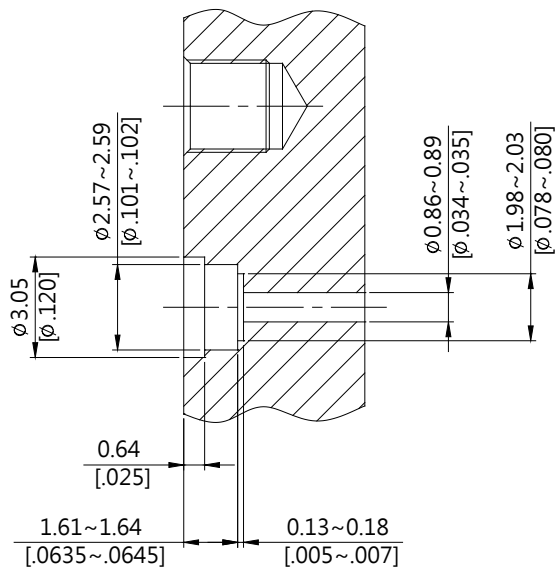

Hermetic seal P/N

SEAL.015

FR015-SEAL1

### 2. Using dielectric with Tab or Launch pin

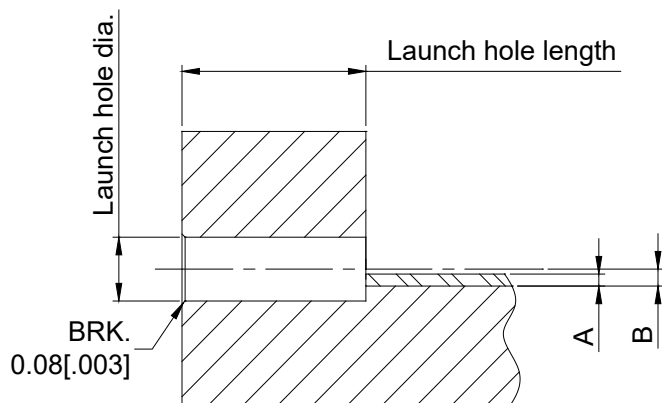

"A" = Substrate thickness

"B" = A + 1/2 Tab or Launch terminal

Dielectric and Tab/Launch pin P/N	Recommended Launch hole dia.	Recommended Launch hole length
FR015-LAUNCH1	$\phi$ 1.23 (.048)	4.75 (.187)
FR015-LAUNCH2	$\phi$ 1.23 (.048)	3.18 (.125)
FR015-TAB2	$\phi$ 1.23 (.048)	4.75 (.187)
FR015-TAB3	$\phi$ 1.23 (.048)	3.18 (.125)

### 3. Using Tab pin

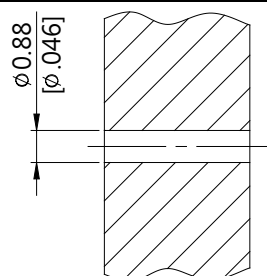

Tab pin P/N

FR015-TAB1

# K8F46C-GA15 (Tested back to back)

S11

