

K8F26E-EM09	2.92mm Field Replaceable Jack, Φ13.97mm (.550inch) 2 Hole Flange With Metal Ring, Accepts Φ0.23mm (.009inch) Pin, 40GHz VSWR 1.15	50Ω
-------------	-----------------------------------------------------------------------------------------------------------------------------------------	-----

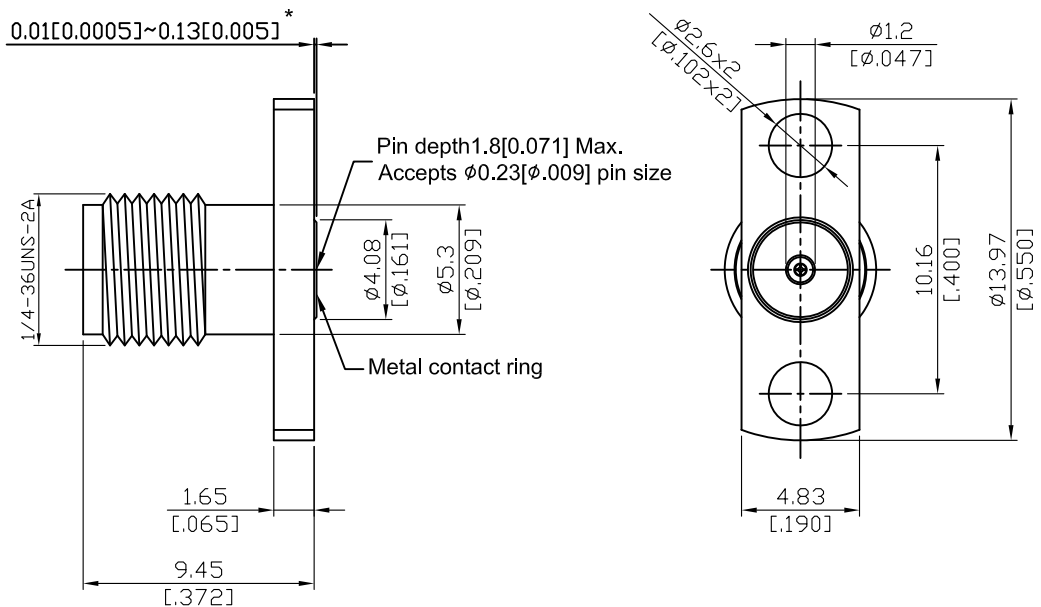

*360° Raised Metal Contact Ring

Parts	Material	Plating (Micro-inch)
Body	Stainless Steel	Passivated
Insulator	PEI	
Contact Pin	Beryllium Copper	Gold 4 Over Nickel-Phosphorus Alloy 80 Over Copper 20
Metal Contact Ring	Beryllium Copper	Gold 4 Over Nickel-Phosphorus Alloy 80 Over Copper 20

--	--

This part number complies with RoHS.

Notice: JYEBAO reserves the right to make modifications deemed appropriate.

K	K8F26E-EM09
<div data-bbox="113 327 513 376" style="border: 1px solid black; padding: 2px;">Interface</div> <p>MIL-STD-348B</p> <p>Mechanically compatible with 3.5 & SMA</p>	
<div data-bbox="113 490 513 539" style="border: 1px solid black; padding: 2px;">Electrical Data</div> <p>Impedance 50Ω</p> <p>Frequency range DC to 40GHz</p> <p>VSWR ≤ 1.15 (DC to 40GHz)</p> <p>Insertion loss $\leq 0.04 \times \sqrt{f(\text{GHz})}$ dB</p> <p>Insulation resistance $\geq 5000\text{M}\Omega$</p> <p>Contact resistance inner conductor $\leq 3\text{m}\Omega$</p> <p>Contact resistance outer conductor $\leq 2\text{m}\Omega$</p> <p>Dielectric withstanding voltage (at sea level) 750 V rms</p> <p>Working Voltage (at sea level) 250 V rms</p> <p>RF leakage $\geq 100\text{dB}$ to 1GHz</p>	
<div data-bbox="113 1084 513 1133" style="border: 1px solid black; padding: 2px;">Mechanical Data</div> <p>Recommended coupling nut torque 11.47 inch lbs</p> <p>Coupling proof torque 15 inch lbs</p> <p>Contact Captivation-axial ≥ 4.9 lbs</p> <p>Durability (mating) ≥ 500</p>	
<div data-bbox="113 1391 513 1440" style="border: 1px solid black; padding: 2px;">Environmental Data</div> <p>Temperature range -40°C to +165°C</p> <p>Thermal shock MIL-STD-202, Method 107, Condition B</p> <p>Moisture resistance MIL-STD-202, Method 206</p> <p>Corrosion MIL-STD-202, Method 101, Condition B</p> <p>RoHS Compliant</p>	
<div data-bbox="113 1744 513 1794" style="border: 1px solid black; padding: 2px;">Accessories</div> <p>Hermetic seal FR009-SEAL1</p> <p>Launch pin & Dielectric transition FR009-LAUNCH1; FR009-LAUNCH2</p> <p>Tab pin & Dielectric transition FR009-TAB2; FR009-TAB3</p> <p>Tab pin FR009-TAB1</p>	

Notice: JYEBAO reserves the right to make modifications deemed appropriate.

Recommended Launch Hole Dimensions :

1. Using Hermetic seals

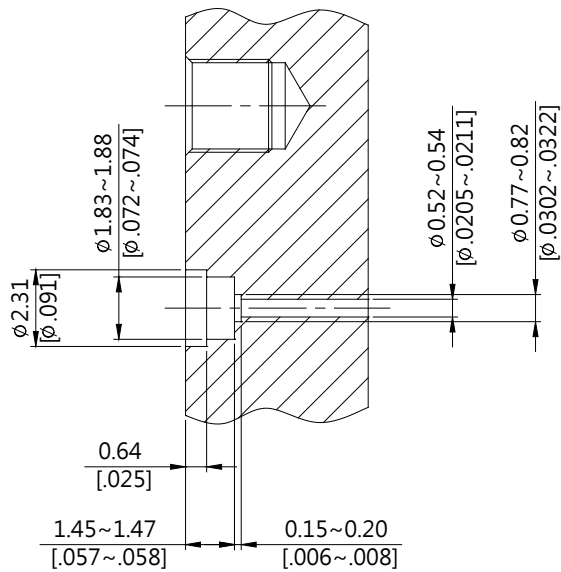

Hermetic seal P/N

FR009-SEAL1

2. Using dielectric with Tab or Launch pin

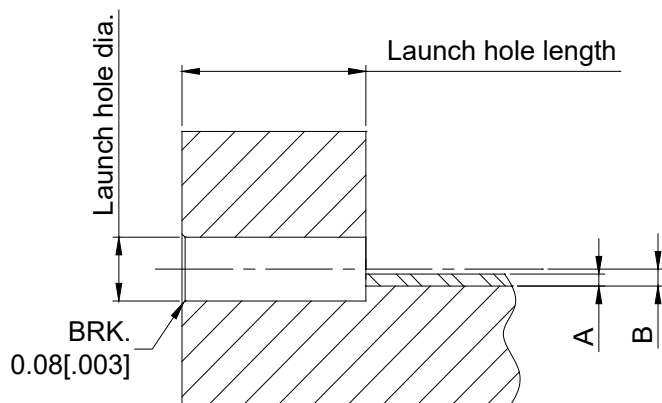

"A" = Substrate thickness

"B" = A + 1/2 Tab or Launch terminal

Dielectric and Tab/ Launch pin P/N	Recommended Launch hole dia.	Recommended Launch hole length
FR009-LAUNCH1	$\phi 0.74 (.029)$	4.75 (.187)
FR009-LAUNCH2	$\phi 0.74 (.029)$	3.18 (.125)
FR009-TAB2	$\phi 0.74 (.029)$	3.18 (.125)
FR009-TAB3	$\phi 0.74 (.029)$	4.75 (.187)

3. Using Tab pin

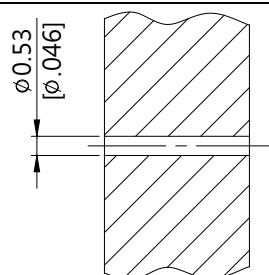

Tab pin P/N

FR009-TAB1

K8F26E-EM09 (Tested back to back)

