

K8F26A-GA12

2.92mm Field Replaceable Jack,
 Φ15.9mm (.625inch) 2 Hole Flange With EMI Gasket,
 Accepts Φ0.3mm (.012inch) Pin, 40GHz VSWR 1.15

50Ω

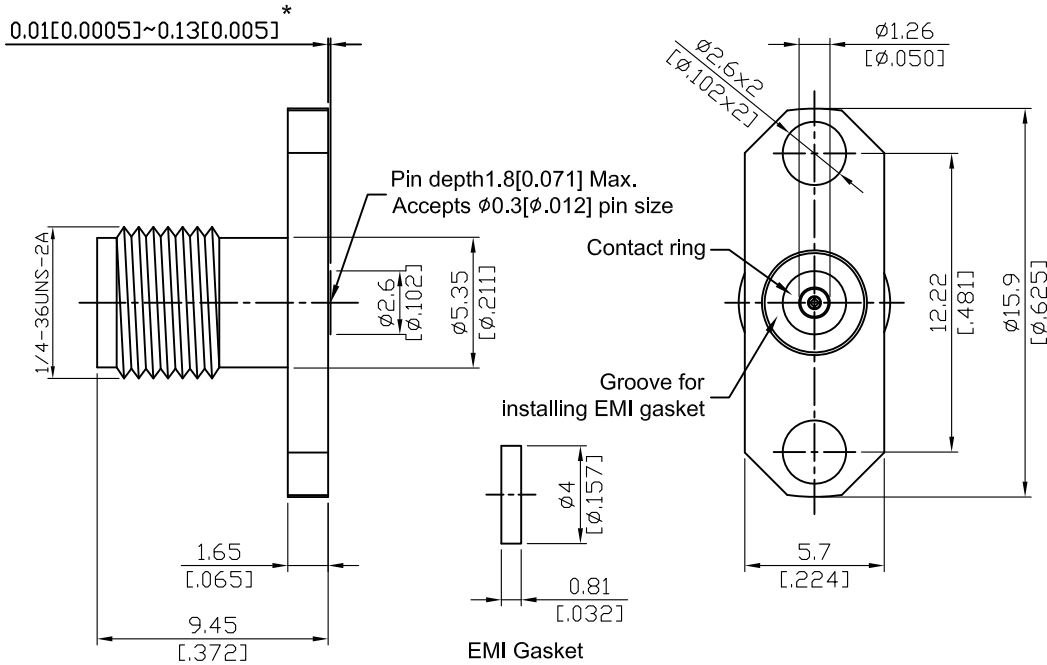

*360° Raised Metal Contact Ring

Parts	Material	Plating (Micro-inch)
Body	Stainless Steel	Passivated
Insulator	PEI	
Contact Pin	Beryllium Copper	Gold 4 Over Nickel-Phosphorus Alloy 80 Over Copper 20
Contact Ring	Stainless Steel	Passivated
EMI Gasket	Conductive Silicone Elastomers	

This part number complies with RoHS.

Notice: JYEBAO reserves the right to make modifications deemed appropriate.

K	K8F26A-GA12
<div data-bbox="113 327 513 376" style="border: 1px solid black; padding: 2px;">Interface</div> <p>MIL-STD-348B</p> <p>Mechanically compatible with 3.5 & SMA</p>	
<div data-bbox="113 495 513 544" style="border: 1px solid black; padding: 2px;">Electrical Data</div> <p>Impedance 50Ω</p> <p>Frequency range DC to 40GHz</p> <p>VSWR ≤ 1.15 (DC to 40GHz)</p> <p>Insertion loss $\leq 0.04 \times \sqrt{f(\text{GHz})}$ dB</p> <p>Insulation resistance $\geq 5000\text{M}\Omega$</p> <p>Contact resistance inner conductor $\leq 3\text{m}\Omega$</p> <p>Contact resistance outer conductor $\leq 2\text{m}\Omega$</p> <p>Dielectric withstanding voltage (at sea level) 750 V rms</p> <p>Working Voltage (at sea level) 250 V rms</p> <p>RF leakage $\geq 100\text{dB}$ to 1GHz</p>	
<div data-bbox="113 1088 513 1137" style="border: 1px solid black; padding: 2px;">Mechanical Data</div> <p>Recommended coupling nut torque 11.47 inch lbs</p> <p>Coupling proof torque 15 inch lbs</p> <p>Contact Captivation-axial ≥ 4.9 lbs</p> <p>Durability (mating) ≥ 500</p>	
<div data-bbox="113 1395 513 1444" style="border: 1px solid black; padding: 2px;">Environmental Data</div> <p>Temperature range -40°C to +150°C</p> <p>Thermal shock MIL-STD-202, Method 107, Condition B</p> <p>Moisture resistance MIL-STD-202, Method 206</p> <p>Corrosion MIL-STD-202, Method 101, Condition B</p> <p>RoHS Compliant</p>	
<div data-bbox="113 1749 513 1798" style="border: 1px solid black; padding: 2px;">Accessories</div> <p>Hermetic seal FR012-SEAL1; FR012-SEAL2; SEAL.012</p> <p>Launch pin & Dielectric transition FR012-LAUNCH1; FR012-LAUNCH2</p> <p>Tab pin & Dielectric transition FR012-TAB2; FR012-TAB3</p> <p>Tab pin FR012-TAB1</p>	

Notice: JYEBAO reserves the right to make modifications deemed appropriate.

Recommended Launch Hole Dimensions :

1. Using Hermetic seals



Hermetic seal P/N

SEAL.012

FR012-SEAL1

FR012-SEAL2

2. Using dielectric with Tab or Launch pin



"A" = Substrate thickness

"B" = A + 1/2 Tab or Launch terminal

Dielectric and Tab/Launch pin P/N	Recommended Launch hole dia.	Recommended Launch hole length
FR012-LAUNCH1	ϕ 0.99 (.039)	4.75 (.187)
FR012-LAUNCH2	ϕ 0.99 (.039)	3.18 (.125)
FR012-TAB2	ϕ 0.99 (.039)	3.18 (.125)
FR012-TAB3	ϕ 0.99 (.039)	4.75 (.187)

3. Using Tab pin



Tab pin P/N

FR012-TAB1

K8F26A-GA12 (Tested back to back)

S11

