

K3F26E-EM09	2.92mm Field Replaceable Plug, Φ13.97mm (.550inch) 2 Hole Flange With Metal Ring, Accepts Φ0.23mm (.009inch) Pin, 40GHz VSWR 1.15	50Ω
--------------------	---	------------

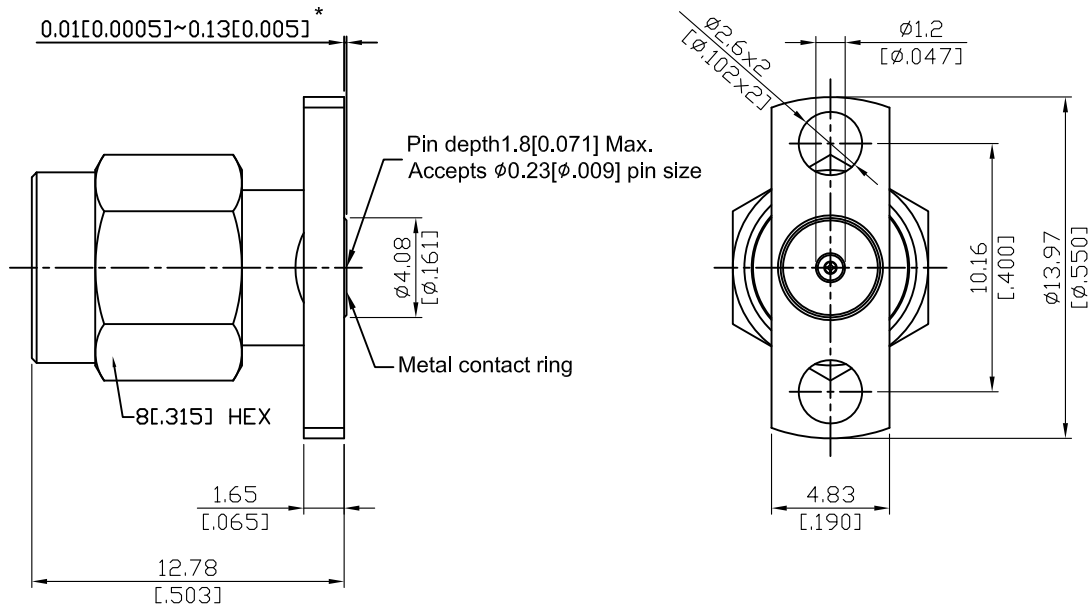

*360° Raised Metal Contact Ring

Parts	Material	Plating (Micro-inch)
Body	Stainless Steel	Passivated
Insulator	PEI	
Contact Pin	Beryllium Copper	Gold 4 Over Nickel-Phosphorus Alloy 80 Over Copper 20
Metal Contact Ring	Beryllium Copper	Gold 4 Over Nickel-Phosphorus Alloy 80 Over Copper 20
Coupling Nut	Stainless Steel	Passivated
Retainer Ring	Beryllium Copper	Tin-Zinc-Copper-Alloy 100 Over Copper 50

--	--

This part number complies with RoHS.
 Notice: JYEBAO reserves the right to make modifications deemed appropriate.

K	K3F26E-EM09
<div style="border: 1px solid black; padding: 2px; margin-bottom: 5px;">Interface</div> MIL-STD-348B Mechanically compatible with 3.5 & SMA	
<div style="border: 1px solid black; padding: 2px; margin-bottom: 5px;">Electrical Data</div> Impedance 50Ω Frequency range DC to 40GHz VSWR ≤ 1.15 (DC to 40GHz) Insertion loss $\leq 0.04 \times \sqrt{f(\text{GHz})}$ dB Insulation resistance $\geq 5000\text{M}\Omega$ Contact resistance inner conductor $\leq 3\text{m}\Omega$ Contact resistance outer conductor $\leq 2\text{m}\Omega$ Dielectric withstanding voltage (at sea level) 750 V rms Working Voltage (at sea level) 250 V rms RF leakage $\geq 100\text{dB}$ to 1GHz	
<div style="border: 1px solid black; padding: 2px; margin-bottom: 5px;">Mechanical Data</div> Recommended coupling nut torque 11.47 inch lbs Coupling proof torque 15 inch lbs Contact Captivation-axial ≥ 4.9 lbs Durability (mating) ≥ 500	
<div style="border: 1px solid black; padding: 2px; margin-bottom: 5px;">Environmental Data</div> Temperature range -40°C to +165°C Thermal shock MIL-STD-202, Method 107, Condition B Moisture resistance MIL-STD-202, Method 206 Corrosion MIL-STD-202, Method 101, Condition B RoHS Compliant	
<div style="border: 1px solid black; padding: 2px; margin-bottom: 5px;">Accessories</div> Hermetic seal FR009-SEAL1 Launch pin & Dielectric transition FR009-LAUNCH1; FR009-LAUNCH2 Tab pin & Dielectric transition FR009-TAB2; FR009-TAB3 Tab pin FR009-TAB1	

Notice: JYEBAO reserves the right to make modifications deemed appropriate.

Recommended Launch Hole Dimensions :

1. Using Hermetic seals

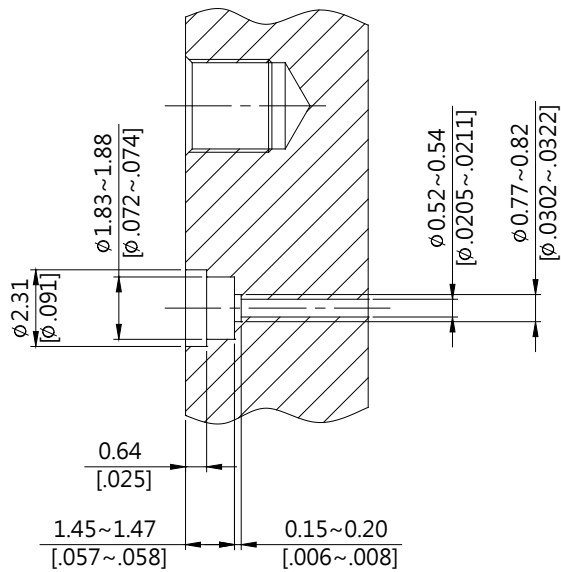

Hermetic seal P/N

FR009-SEAL1

2. Using dielectric with Tab or Launch pin



"A" = Substrate thickness

"B" = A + 1/2 Tab or Launch terminal

Dielectric and Tab/ Launch pin P/N	Recommended Launch hole dia.	Recommended Launch hole length
FR009-LAUNCH1	ϕ 0.74 (.029)	4.75 (.187)
FR009-LAUNCH2	ϕ 0.74 (.029)	3.18 (.125)
FR009-TAB2	ϕ 0.74 (.029)	3.18 (.125)
FR009-TAB3	ϕ 0.74 (.029)	4.75 (.187)

3. Using Tab pin



Tab pin P/N

FR009-TAB1