

NO.	COMPONENTS	IMPEDANCE
1	K MALE	50 OHM
2	5002	50 OHM
3	HEAT SHRINKING TUBE	
4	K MALE RIGHT ANGLE	50 OHM

REVISION			
REV.	DESCRIPTON	DATE	APPROVED
-	INITIAL RELEASE	2021/04/15	

K MALE

K MALE  
RIGHT ANGLE

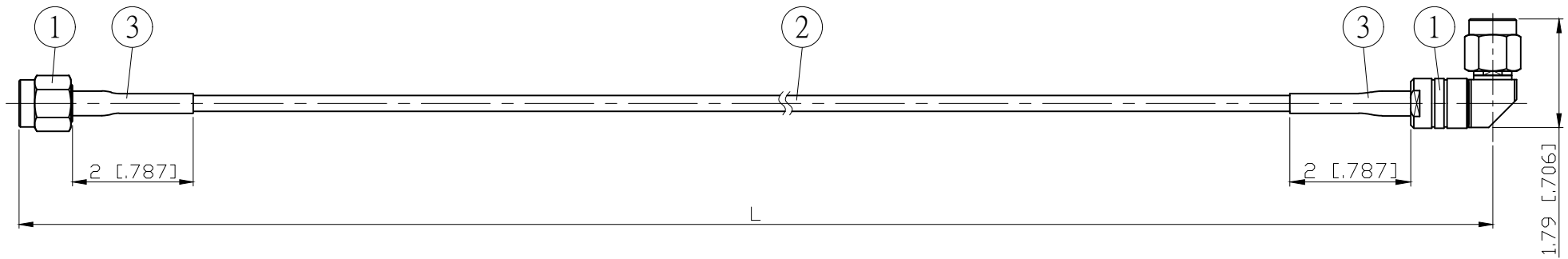

L CM (INCH)	L1 M (MM)
50 (19.685)	0.491 (491.0)
100 (39.370)	0.991 (991.0)
150 (59.055)	1.491 (1491.0)
200 (78.740)	1.991 (1991.0)
Custom length in CM	- - -

Spec	Phase stability vs bending <sup>(1)</sup>	Amplitude stability vs bending <sup>(2)</sup>	Max VSWR	Max IL	Flexure life cycle <sup>(3)</sup>
3GHz	±0.3° typ / ±0.5° max	±0.005dB typ / ±0.01dB max	1.20 : 1	≤ (0.0128dB/cm*Lcm)+0.15dB	≥ 10000
6GHz	±0.5° typ / ±0.75° max	±0.0075dB typ / ±0.015dB max	1.25 : 1	≤ (0.0189dB/cm*Lcm)+0.20dB	
12.4GHz	±0.75° typ / ±1.0° max	±0.010dB typ / ±0.02dB max	1.30 : 1	≤ (0.0293dB/cm*Lcm)+0.25dB	
18GHz	±1.0° typ / ±1.5° max	±0.015dB typ / ±0.03dB max	1.35 : 1	≤ (0.0361dB/cm*Lcm)+0.30dB	
26.5GHz	±1.5° typ / ±2.0° max	±0.020dB typ / ±0.04dB max	1.35 : 1	≤ (0.0450dB/cm*Lcm)+0.40dB	
40GHz	±2.0° typ / ±3.5° max	±0.030dB typ / ±0.06dB max	1.35 : 1	≤ (0.0568dB/cm*Lcm)+0.50dB	

Notes:

- Operating Temp.: -55°C / +105°C
- Static bend radius 5.1mm
- Dynamic bend radius 30mm
- RoHS Compliant

- (1) Per IEC 60966-1, section 8.6, method 1
- (2) Per IEC 60966-1, section 8.4
- (3) Per IEC 60966-1, section 9.3

					STANDARD	REV -	UNIT CM(INCH)	<b>JYE BAO CO., LTD.</b>	
					APPROVED			TAIPEI TAIWAN	
					CHECKED	DATE		DESCRIPTION CABLE ASSEMBLY K PLUG TO K PLUG R/A	
					DRAWING	DATE		JYE BAO DRAWING NO. K30K39-52L-40GXXX	
4	K3200S-M5002	K PLUG R/A	1	EA	LENGTH TOLERANCE IS ±1.5% OR ±10MM, WHICHEVER IS GREATER.	<i>Albert</i>			
3	G5(F)-4.0MM-BLACK	TUBE	0.04	M					
2	5002	CABLE	SEE TABLE L1	M					
1	K3300-0405	K PLUG	1	EA					
NO.	PARTS NO.	DESCRIPTION	Q'TY	U/M					