

BNC8550-0000/HDPE	BNC jack bulkhead with solder cup contact; radiation resistant; 3GHz VSWR 1.2	50Ω
-------------------	--	-----

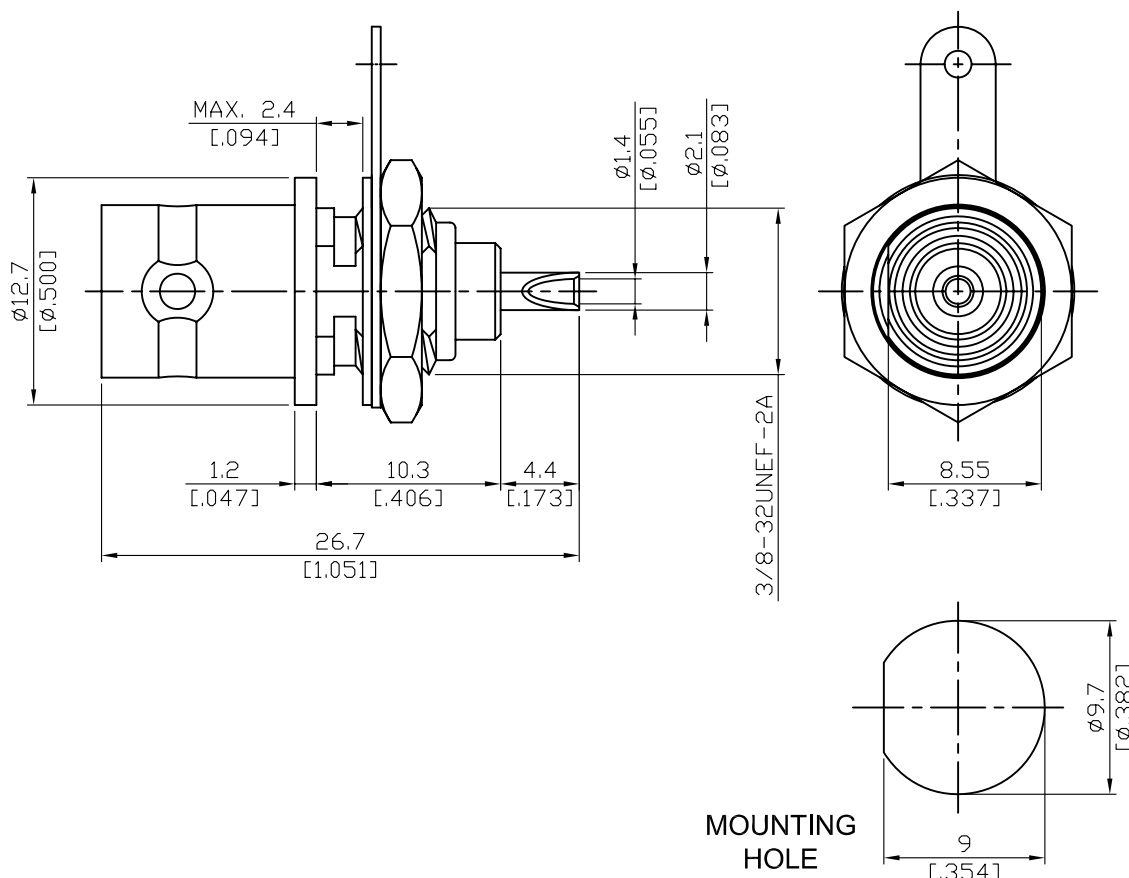

Parts	Material	Plating ( Micro-inch )
Body	Brass	Tin-Zinc-Copper-Alloy 100 Over Copper 50
Insulator	High Density Polyethylene	
Contact Pin	P.Bronze	Gold 4 Over Nickel-Phosphorus Alloy 80 Over Copper 20
Lock Washer	Brass	Tin-Zinc-Copper-Alloy 100 Over Copper 50
Solder Tag	Brass	Tin-Zinc-Copper-Alloy 100 Over Copper 50
Hex Nut	Brass	Tin-Zinc-Copper-Alloy 100 Over Copper 50

--	--

This part number complies with RoHS.  
 Notice: JYEBAO reserves the right to make modifications deemed appropriate.

BNC	BNC8550-0000/HDPE																		
<div data-bbox="167 344 568 389" style="border: 1px solid black; padding: 2px;">Interface</div> <p>MIL-STD-348B</p>																			
<div data-bbox="167 512 568 557" style="border: 1px solid black; padding: 2px;">Electrical Data</div> <table border="0" style="width: 100%;"> <tr> <td style="width: 50%;">Impedance</td> <td style="width: 50%;">50Ω</td> </tr> <tr> <td>Frequency range</td> <td>DC to 3GHz</td> </tr> <tr> <td>VSWR</td> <td>≤ 1.2 (DC to 3GHz)</td> </tr> <tr> <td>Insertion loss</td> <td>≤ 0.1 x √f(GHz)dB</td> </tr> <tr> <td>Insulation resistance</td> <td>≥ 5000MΩ</td> </tr> <tr> <td>Contact resistance inner conductor</td> <td>≤ 1.5mΩ</td> </tr> <tr> <td>Contact resistance outer conductor</td> <td>≤ 1mΩ</td> </tr> <tr> <td>Dielectric withstanding voltage (at sea level)</td> <td>1500 V rms</td> </tr> <tr> <td>Working voltage (at sea level)</td> <td>500 V rms</td> </tr> </table>		Impedance	50Ω	Frequency range	DC to 3GHz	VSWR	≤ 1.2 (DC to 3GHz)	Insertion loss	≤ 0.1 x √f(GHz)dB	Insulation resistance	≥ 5000MΩ	Contact resistance inner conductor	≤ 1.5mΩ	Contact resistance outer conductor	≤ 1mΩ	Dielectric withstanding voltage (at sea level)	1500 V rms	Working voltage (at sea level)	500 V rms
Impedance	50Ω																		
Frequency range	DC to 3GHz																		
VSWR	≤ 1.2 (DC to 3GHz)																		
Insertion loss	≤ 0.1 x √f(GHz)dB																		
Insulation resistance	≥ 5000MΩ																		
Contact resistance inner conductor	≤ 1.5mΩ																		
Contact resistance outer conductor	≤ 1mΩ																		
Dielectric withstanding voltage (at sea level)	1500 V rms																		
Working voltage (at sea level)	500 V rms																		
<div data-bbox="167 1055 568 1099" style="border: 1px solid black; padding: 2px;">Mechanical Data</div> <table border="0" style="width: 100%;"> <tr> <td style="width: 50%;">Recommended coupling nut torque</td> <td style="width: 50%;">0.6 to 2.5 inch lbs</td> </tr> <tr> <td>Contact captivation-axial</td> <td>≥ 6.1 lbs</td> </tr> <tr> <td>Durability (mating)</td> <td>≥ 500</td> </tr> </table>		Recommended coupling nut torque	0.6 to 2.5 inch lbs	Contact captivation-axial	≥ 6.1 lbs	Durability (mating)	≥ 500												
Recommended coupling nut torque	0.6 to 2.5 inch lbs																		
Contact captivation-axial	≥ 6.1 lbs																		
Durability (mating)	≥ 500																		
<div data-bbox="167 1364 568 1408" style="border: 1px solid black; padding: 2px;">Environmental Data</div> <table border="0" style="width: 100%;"> <tr> <td style="width: 50%;">Temperature range</td> <td style="width: 50%;">-40°C to +80°C</td> </tr> <tr> <td>Thermal shock</td> <td>MIL-STD-202, Method 107, Condition B</td> </tr> <tr> <td>Moisture resistance</td> <td>MIL-STD-202, Method 106</td> </tr> <tr> <td>Corrosion</td> <td>MIL-STD-202, Method 101, Condition B</td> </tr> <tr> <td>RoHS</td> <td>Compliant</td> </tr> </table>		Temperature range	-40°C to +80°C	Thermal shock	MIL-STD-202, Method 107, Condition B	Moisture resistance	MIL-STD-202, Method 106	Corrosion	MIL-STD-202, Method 101, Condition B	RoHS	Compliant								
Temperature range	-40°C to +80°C																		
Thermal shock	MIL-STD-202, Method 107, Condition B																		
Moisture resistance	MIL-STD-202, Method 106																		
Corrosion	MIL-STD-202, Method 101, Condition B																		
RoHS	Compliant																		
<div data-bbox="167 1715 568 1760" style="border: 1px solid black; padding: 2px;">Tooling</div>																			

Notice: JYEBAO reserves the right to make modifications deemed appropriate.

# BNC8550-0000/HDPE

S11

