

BNC84CT-9000 **BNC Jack PCB Mount Right Angle**
With Round Contact (Φ1); 2.9GHz VSWR 1.2 **50Ω**

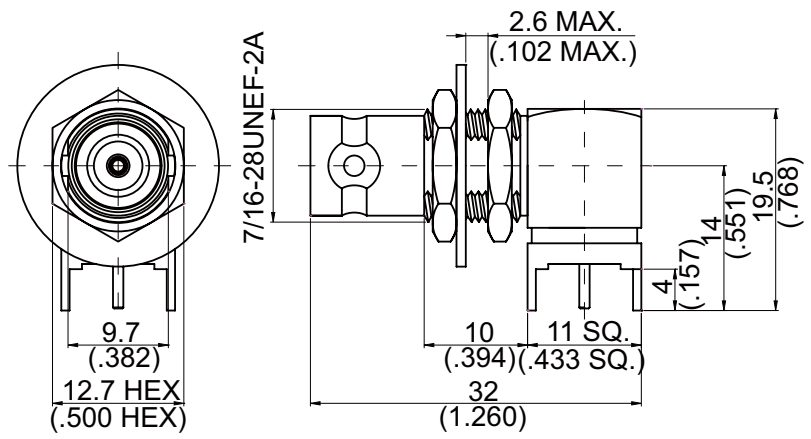

MOUNTING HOLE

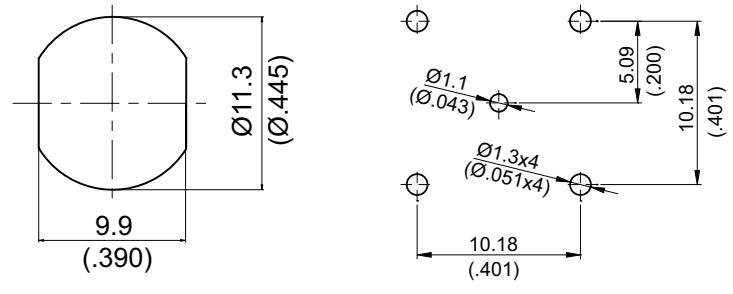

Parts	Material	Plating (Micro-inch)
Nut Hex	Brass	Tin-Zinc-Copper-Alloy 100 Over Copper 50
Cover	Brass	Tin-Zinc-Copper-Alloy 100 Over Copper 50
Contact Pin	Phosphor Bronze	Gold 4 Over Nickel-Phosphorus Alloy 80 Over Copper 20
Insulator	Teflon	
Body	Brass	Tin-Zinc-Copper-Alloy 100 Over Copper 50

Weight: 20.92 g

This part number complies with RoHS.

Notice: JYEBAO reserves the right to make modifications deemed appropriate.

BNC	BNC84CT-9000																		
<div data-bbox="167 347 568 392" style="border: 1px solid black; padding: 2px;">Interface</div> <p>MIL-STD-348B</p>																			
<div data-bbox="167 510 568 555" style="border: 1px solid black; padding: 2px;">Electrical Data</div> <table border="0" style="width: 100%;"> <tr> <td style="width: 50%;">Impedance</td> <td style="width: 50%;">50Ω</td> </tr> <tr> <td>Frequency range</td> <td>DC to 2.9GHz</td> </tr> <tr> <td>VSWR</td> <td>≦ 1.2 (DC to 2.9GHz)</td> </tr> <tr> <td>Insertion loss</td> <td>≦ 0.1 x √f(GHz)dB</td> </tr> <tr> <td>Insulation resistance</td> <td>≧ 5000MΩ</td> </tr> <tr> <td>Contact resistance inner conductor</td> <td>≦ 1.5mΩ</td> </tr> <tr> <td>Contact resistance outer conductor</td> <td>≦ 1mΩ</td> </tr> <tr> <td>Dielectric withstanding voltage (at sea level)</td> <td>1500 V rms</td> </tr> <tr> <td>Working voltage (at sea level)</td> <td>500 V rms</td> </tr> </table>		Impedance	50Ω	Frequency range	DC to 2.9GHz	VSWR	≦ 1.2 (DC to 2.9GHz)	Insertion loss	≦ 0.1 x √f(GHz)dB	Insulation resistance	≧ 5000MΩ	Contact resistance inner conductor	≦ 1.5mΩ	Contact resistance outer conductor	≦ 1mΩ	Dielectric withstanding voltage (at sea level)	1500 V rms	Working voltage (at sea level)	500 V rms
Impedance	50Ω																		
Frequency range	DC to 2.9GHz																		
VSWR	≦ 1.2 (DC to 2.9GHz)																		
Insertion loss	≦ 0.1 x √f(GHz)dB																		
Insulation resistance	≧ 5000MΩ																		
Contact resistance inner conductor	≦ 1.5mΩ																		
Contact resistance outer conductor	≦ 1mΩ																		
Dielectric withstanding voltage (at sea level)	1500 V rms																		
Working voltage (at sea level)	500 V rms																		
<div data-bbox="167 1055 568 1099" style="border: 1px solid black; padding: 2px;">Mechanical Data</div> <table border="0" style="width: 100%;"> <tr> <td style="width: 50%;">Recommended coupling nut torque</td> <td style="width: 50%;">0.6 to 2.5 inch lbs</td> </tr> <tr> <td>Contact captivation-axial</td> <td>≧ 6.1 lbs</td> </tr> <tr> <td>Durability (mating)</td> <td>≧ 500</td> </tr> </table>		Recommended coupling nut torque	0.6 to 2.5 inch lbs	Contact captivation-axial	≧ 6.1 lbs	Durability (mating)	≧ 500												
Recommended coupling nut torque	0.6 to 2.5 inch lbs																		
Contact captivation-axial	≧ 6.1 lbs																		
Durability (mating)	≧ 500																		
<div data-bbox="167 1361 568 1406" style="border: 1px solid black; padding: 2px;">Environmental Data</div> <table border="0" style="width: 100%;"> <tr> <td style="width: 50%;">Temperature range</td> <td style="width: 50%;">-65°C to +165°C</td> </tr> <tr> <td>Thermal shock</td> <td>MIL-STD-202, Method 107, Condition B</td> </tr> <tr> <td>Moisture resistance</td> <td>MIL-STD-202, Method 106</td> </tr> <tr> <td>Corrosion</td> <td>MIL-STD-202, Method 101, Condition B</td> </tr> <tr> <td>RoHS</td> <td>Compliant</td> </tr> </table>		Temperature range	-65°C to +165°C	Thermal shock	MIL-STD-202, Method 107, Condition B	Moisture resistance	MIL-STD-202, Method 106	Corrosion	MIL-STD-202, Method 101, Condition B	RoHS	Compliant								
Temperature range	-65°C to +165°C																		
Thermal shock	MIL-STD-202, Method 107, Condition B																		
Moisture resistance	MIL-STD-202, Method 106																		
Corrosion	MIL-STD-202, Method 101, Condition B																		
RoHS	Compliant																		
<div data-bbox="167 1715 568 1760" style="border: 1px solid black; padding: 2px;">Tooling</div>																			

Notice: JYEBAO reserves the right to make modifications deemed appropriate.

BNC84CT-9000

S11

