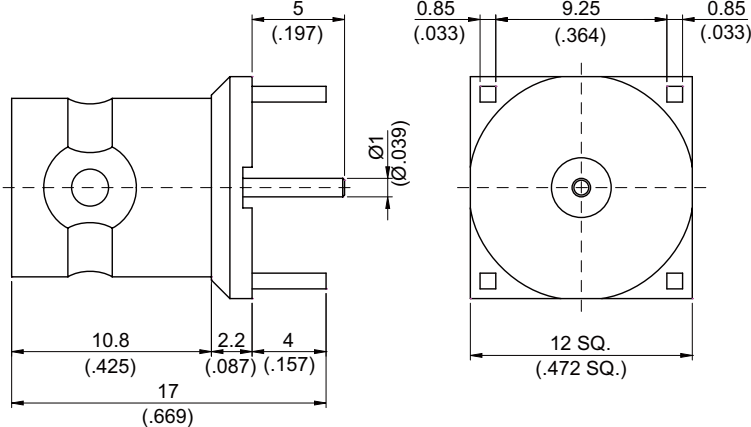
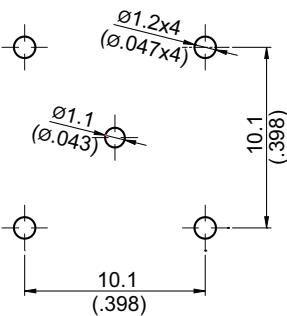

| <p>BNC84AV-0000</p> | <p>BNC Jack PCB Mount With Round Contact (Φ1); 4GHz VSWR 1.2 50Ω</p> | | | | | | | | | | | | |
|---|--|---|----------|----------------------|-------------|-----------------|---|-----------|--------|--|------|-------|--|
|  <p style="text-align: center; margin-top: 10px;">MOUNTING HOLE</p>  | | | | | | | | | | | | | |
| <table border="1" style="width: 100%; border-collapse: collapse;"> <thead> <tr> <th style="width: 20%;">Parts</th> <th style="width: 20%;">Material</th> <th style="width: 60%;">Plating (Micro-inch)</th> </tr> </thead> <tbody> <tr> <td>Contact Pin</td> <td>Phosphor Bronze</td> <td>Gold 4 Over Nickel-Phosphorus Alloy 80 Over Copper 20</td> </tr> <tr> <td>Insulator</td> <td>Teflon</td> <td></td> </tr> <tr> <td>Body</td> <td>Brass</td> <td>Tin-Zinc-Copper-Alloy 100 Over Copper 50</td> </tr> </tbody> </table> | | Parts | Material | Plating (Micro-inch) | Contact Pin | Phosphor Bronze | Gold 4 Over Nickel-Phosphorus Alloy 80 Over Copper 20 | Insulator | Teflon | | Body | Brass | Tin-Zinc-Copper-Alloy 100 Over Copper 50 |
| Parts | Material | Plating (Micro-inch) | | | | | | | | | | | |
| Contact Pin | Phosphor Bronze | Gold 4 Over Nickel-Phosphorus Alloy 80 Over Copper 20 | | | | | | | | | | | |
| Insulator | Teflon | | | | | | | | | | | | |
| Body | Brass | Tin-Zinc-Copper-Alloy 100 Over Copper 50 | | | | | | | | | | | |
| <p>Weight: 4.14 g</p> | | | | | | | | | | | | | |

This part number complies with RoHS.

Notice: JYEBAO reserves the right to make modifications deemed appropriate.

| BNC | BNC84AV-0000 | | | | | | | | | | | | | | | | | | |
|---|--------------------------------------|---------------------------------|---------------------|---------------------------|--------------------------------------|---------------------|-------------------------|----------------|--------------------------------------|-----------------------|-----------|------------------------------------|---------|------------------------------------|-------|--|------------|--------------------------------|-----------|
| <div data-bbox="167 344 568 389" style="border: 1px solid black; padding: 2px;">Interface</div> <p>MIL-STD-348B</p> | | | | | | | | | | | | | | | | | | | |
| <div data-bbox="167 512 568 557" style="border: 1px solid black; padding: 2px;">Electrical Data</div> <table border="0" style="width: 100%;"> <tr> <td style="width: 50%;">Impedance</td> <td style="width: 50%;">50Ω</td> </tr> <tr> <td>Frequency range</td> <td>DC to 4GHz</td> </tr> <tr> <td>VSWR</td> <td>≤ 1.2 (DC to 4GHz)</td> </tr> <tr> <td>Insertion loss</td> <td>≤ 0.1 x √f(GHz)dB</td> </tr> <tr> <td>Insulation resistance</td> <td>≥ 5000MΩ</td> </tr> <tr> <td>Contact resistance inner conductor</td> <td>≤ 1.5mΩ</td> </tr> <tr> <td>Contact resistance outer conductor</td> <td>≤ 1mΩ</td> </tr> <tr> <td>Dielectric withstanding voltage (at sea level)</td> <td>1500 V rms</td> </tr> <tr> <td>Working voltage (at sea level)</td> <td>500 V rms</td> </tr> </table> | | Impedance | 50Ω | Frequency range | DC to 4GHz | VSWR | ≤ 1.2 (DC to 4GHz) | Insertion loss | ≤ 0.1 x √f(GHz)dB | Insulation resistance | ≥ 5000MΩ | Contact resistance inner conductor | ≤ 1.5mΩ | Contact resistance outer conductor | ≤ 1mΩ | Dielectric withstanding voltage (at sea level) | 1500 V rms | Working voltage (at sea level) | 500 V rms |
| Impedance | 50Ω | | | | | | | | | | | | | | | | | | |
| Frequency range | DC to 4GHz | | | | | | | | | | | | | | | | | | |
| VSWR | ≤ 1.2 (DC to 4GHz) | | | | | | | | | | | | | | | | | | |
| Insertion loss | ≤ 0.1 x √f(GHz)dB | | | | | | | | | | | | | | | | | | |
| Insulation resistance | ≥ 5000MΩ | | | | | | | | | | | | | | | | | | |
| Contact resistance inner conductor | ≤ 1.5mΩ | | | | | | | | | | | | | | | | | | |
| Contact resistance outer conductor | ≤ 1mΩ | | | | | | | | | | | | | | | | | | |
| Dielectric withstanding voltage (at sea level) | 1500 V rms | | | | | | | | | | | | | | | | | | |
| Working voltage (at sea level) | 500 V rms | | | | | | | | | | | | | | | | | | |
| <div data-bbox="167 1055 568 1099" style="border: 1px solid black; padding: 2px;">Mechanical Data</div> <table border="0" style="width: 100%;"> <tr> <td style="width: 50%;">Recommended coupling nut torque</td> <td style="width: 50%;">0.6 to 2.5 inch lbs</td> </tr> <tr> <td>Contact captivation-axial</td> <td>≥ 6.1 lbs</td> </tr> <tr> <td>Durability (mating)</td> <td>≥ 500</td> </tr> </table> | | Recommended coupling nut torque | 0.6 to 2.5 inch lbs | Contact captivation-axial | ≥ 6.1 lbs | Durability (mating) | ≥ 500 | | | | | | | | | | | | |
| Recommended coupling nut torque | 0.6 to 2.5 inch lbs | | | | | | | | | | | | | | | | | | |
| Contact captivation-axial | ≥ 6.1 lbs | | | | | | | | | | | | | | | | | | |
| Durability (mating) | ≥ 500 | | | | | | | | | | | | | | | | | | |
| <div data-bbox="167 1361 568 1406" style="border: 1px solid black; padding: 2px;">Environmental Data</div> <table border="0" style="width: 100%;"> <tr> <td style="width: 50%;">Temperature range</td> <td style="width: 50%;">-65°C to +165°C</td> </tr> <tr> <td>Thermal shock</td> <td>MIL-STD-202, Method 107, Condition B</td> </tr> <tr> <td>Moisture resistance</td> <td>MIL-STD-202, Method 106</td> </tr> <tr> <td>Corrosion</td> <td>MIL-STD-202, Method 101, Condition B</td> </tr> <tr> <td>RoHS</td> <td>Compliant</td> </tr> </table> | | Temperature range | -65°C to +165°C | Thermal shock | MIL-STD-202, Method 107, Condition B | Moisture resistance | MIL-STD-202, Method 106 | Corrosion | MIL-STD-202, Method 101, Condition B | RoHS | Compliant | | | | | | | | |
| Temperature range | -65°C to +165°C | | | | | | | | | | | | | | | | | | |
| Thermal shock | MIL-STD-202, Method 107, Condition B | | | | | | | | | | | | | | | | | | |
| Moisture resistance | MIL-STD-202, Method 106 | | | | | | | | | | | | | | | | | | |
| Corrosion | MIL-STD-202, Method 101, Condition B | | | | | | | | | | | | | | | | | | |
| RoHS | Compliant | | | | | | | | | | | | | | | | | | |
| <div data-bbox="167 1715 568 1760" style="border: 1px solid black; padding: 2px;">Tooling</div> | | | | | | | | | | | | | | | | | | | |

Notice: JYEBAO reserves the right to make modifications deemed appropriate.

BNC84AV-0000

S11

