

BNC3100-0179	BNC Plug Crimp For RG179 3GHz VSWR1.2		75Ω
Parts	Material	Plating (Micro-inch)	
Ferrule	Brass	Tin-Zinc-Copper-Alloy 100 Over Copper 50	
Contact Pin	Brass	Gold 4 Over Nickel-Phosphorus Alloy 80 Over Copper 20	
Gasket	Silicone		
Washer	Brass	Tin-Zinc-Copper-Alloy 100 Over Copper 50	
Spring	SK5	Tin-Zinc-Copper-Alloy 100 Over Copper 50	
Insulator	Teflon		
Body	Brass	Tin-Zinc-Copper-Alloy 100 Over Copper 50	
Coupling Nut	Brass	Tin-Zinc-Copper-Alloy 100 Over Copper 50	
Weight: 9.40 g Suitable Cables: RG179, RG179-FEP			

This part number complies with RoHS.

Notice: JYEBAO reserves the right to make modifications deemed appropriate.

BNC	BNC3100-0179																		
<div data-bbox="167 344 568 389" style="border: 1px solid black; padding: 2px;">Interface</div> <p>MIL-STD-348B</p>																			
<div data-bbox="167 512 568 557" style="border: 1px solid black; padding: 2px;">Electrical Data</div> <table border="0" style="width: 100%;"> <tr> <td style="width: 50%;">Impedance</td> <td style="width: 50%;">75Ω</td> </tr> <tr> <td>Frequency range</td> <td>DC to 3GHz</td> </tr> <tr> <td>VSWR</td> <td>≤ 1.2 (DC to 3GHz)</td> </tr> <tr> <td>Insertion loss</td> <td>≤ 0.1 x √f(GHz)dB</td> </tr> <tr> <td>Insulation resistance</td> <td>≥ 5000MΩ</td> </tr> <tr> <td>Contact resistance inner conductor</td> <td>≤ 1.5mΩ</td> </tr> <tr> <td>Contact resistance outer conductor</td> <td>≤ 1mΩ</td> </tr> <tr> <td>Dielectric withstanding Voltage (at sea level)</td> <td>1500 V rms</td> </tr> <tr> <td>Working voltage (at sea level)</td> <td>500 V rms</td> </tr> </table>		Impedance	75Ω	Frequency range	DC to 3GHz	VSWR	≤ 1.2 (DC to 3GHz)	Insertion loss	≤ 0.1 x √f(GHz)dB	Insulation resistance	≥ 5000MΩ	Contact resistance inner conductor	≤ 1.5mΩ	Contact resistance outer conductor	≤ 1mΩ	Dielectric withstanding Voltage (at sea level)	1500 V rms	Working voltage (at sea level)	500 V rms
Impedance	75Ω																		
Frequency range	DC to 3GHz																		
VSWR	≤ 1.2 (DC to 3GHz)																		
Insertion loss	≤ 0.1 x √f(GHz)dB																		
Insulation resistance	≥ 5000MΩ																		
Contact resistance inner conductor	≤ 1.5mΩ																		
Contact resistance outer conductor	≤ 1mΩ																		
Dielectric withstanding Voltage (at sea level)	1500 V rms																		
Working voltage (at sea level)	500 V rms																		
<div data-bbox="167 1055 568 1099" style="border: 1px solid black; padding: 2px;">Mechanical Data</div> <table border="0" style="width: 100%;"> <tr> <td style="width: 50%;">Recommended coupling nut torque</td> <td style="width: 50%;">0.6 to 2.5 inch lbs</td> </tr> <tr> <td>Coupling nut retention force</td> <td>≥ 101.2 lbs</td> </tr> <tr> <td>Contact captivation-axial</td> <td>≥ 6.1 lbs</td> </tr> <tr> <td>Durability (mating)</td> <td>≥ 500</td> </tr> </table>		Recommended coupling nut torque	0.6 to 2.5 inch lbs	Coupling nut retention force	≥ 101.2 lbs	Contact captivation-axial	≥ 6.1 lbs	Durability (mating)	≥ 500										
Recommended coupling nut torque	0.6 to 2.5 inch lbs																		
Coupling nut retention force	≥ 101.2 lbs																		
Contact captivation-axial	≥ 6.1 lbs																		
Durability (mating)	≥ 500																		
<div data-bbox="167 1364 568 1408" style="border: 1px solid black; padding: 2px;">Environmental Data</div> <table border="0" style="width: 100%;"> <tr> <td style="width: 50%;">Temperature range</td> <td style="width: 50%;">-65°C to +165°C</td> </tr> <tr> <td>Thermal shock</td> <td>MIL-STD-202, Method 107, Condition B</td> </tr> <tr> <td>Moisture resistance</td> <td>MIL-STD-202, Method 106</td> </tr> <tr> <td>Corrosion</td> <td>MIL-STD-202, Method 101, Condition B</td> </tr> <tr> <td>RoHS</td> <td>Compliant</td> </tr> </table>		Temperature range	-65°C to +165°C	Thermal shock	MIL-STD-202, Method 107, Condition B	Moisture resistance	MIL-STD-202, Method 106	Corrosion	MIL-STD-202, Method 101, Condition B	RoHS	Compliant								
Temperature range	-65°C to +165°C																		
Thermal shock	MIL-STD-202, Method 107, Condition B																		
Moisture resistance	MIL-STD-202, Method 106																		
Corrosion	MIL-STD-202, Method 101, Condition B																		
RoHS	Compliant																		
<div data-bbox="167 1715 568 1760" style="border: 1px solid black; padding: 2px;">Tooling</div>																			

Notice: JYEBAO reserves the right to make modifications deemed appropriate.

JYE BAO CO., LTD.

CABLE ASSEMBLY INSTRUCTION

BNC3100-0179	DATE	2017/03/27	REV	—
--------------	------	------------	-----	---

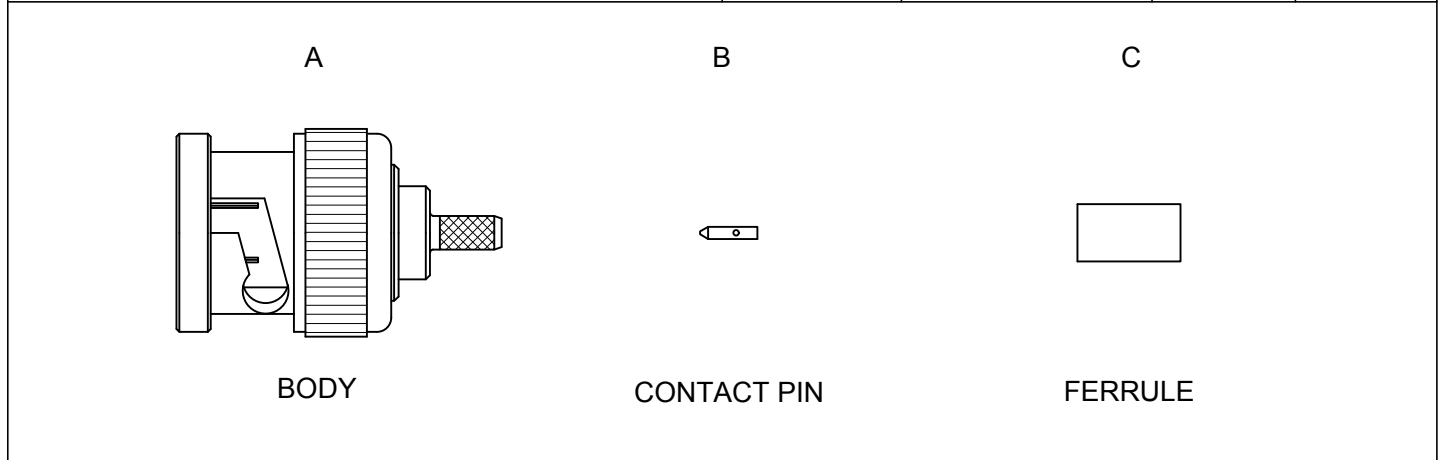

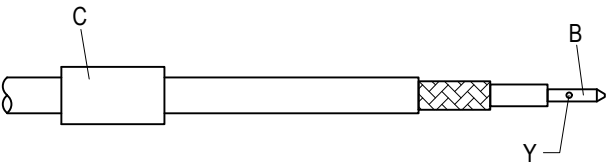
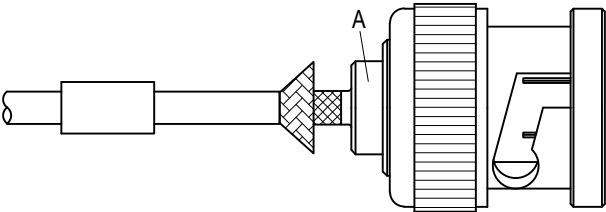
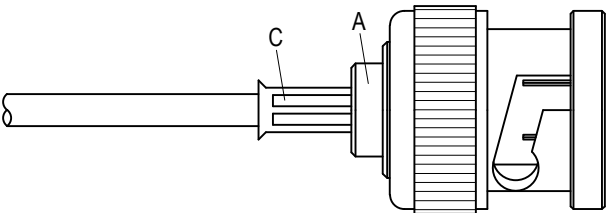

DIAGRAM	ASSEMBLY INSTRUCTION
---------	----------------------

	<p>Step 1: STRIP AS SHOWN.</p>
--	--------------------------------

	<p>Step 2: SLIDE FERRULE " C " OVER CABLE. Step 3: PUT CONTACT PIN " B " ON CENTER CONDUCTOR AND SOLDER OR CRIMP IN " Y ". (USE SQUARE 0.7mm/0.028inch SECTION OF INSERT-A IF CRIMPED)</p>
---	--

	<p>Step 4: LOOSEN BRAIDING AND SLIDE CONNECTOR " A " IN PLACE.</p>
---	--

	<p>Step 5: SLIDE FERRULE " C " TOWARDS THE CONNECTOR " A " AND CRIMP. (USE 3.3mm/0.130inch HEX SECTION OF INSERT-A)</p>
---	--

This part number complies with RoHS.
 Notice: JYEBAO reserves the right to make modifications deemed appropriate.

APPROVED	CHECKED	DRAWING
----------	---------	---------

Albert

BNC3100-0179

S11

