

BMA8362-9141/W

BMA Jack Solder 2-Hole Flange Right Angle
For RG402; 11GHz VSWR 1.2

50Ω

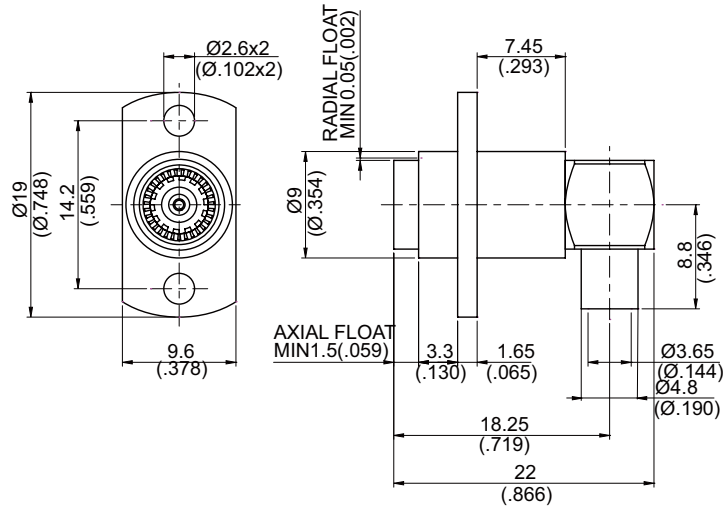

MOUNTING HOLE

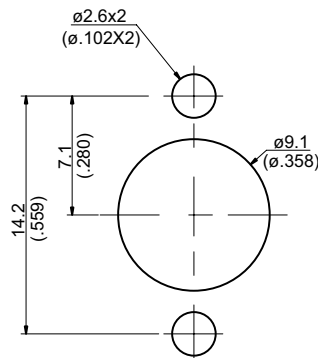

Parts	Material	Plating (Micro-inch)
Cover	Brass	Tin-Zinc-Copper-Alloy 100 Over Copper 50
Spring	Stainless	
Contact Body	Brass	Tin-Zinc-Copper-Alloy 100 Over Copper 50
Contact Pin	Beryllium Copper	Gold 4 Over Nickel-Phosphorous Alloy 80 Over Copper 20
Insulator	Teflon	
Flange Body	Brass	Tin-Zinc-Copper-Alloy 100 Over Copper 50
Spring Washer	Beryllium Copper	Gold 4 Over Nickel-Phosphorous Alloy 80 Over Copper 20
Spring Ring	Beryllium Copper	Gold 4 Over Nickel-Phosphorous Alloy 80 Over Copper 20
Solder Body	Brass	Tin-Zinc-Copper-Alloy 100 Over Copper 50

Suitable Cables: Semi-rigid.141

This part number complies with RoHS.



Notice: JYEBAO reserves the right to make modifications deemed appropriate.

BMA	BMA8362-9141/W																		
<div style="border: 1px solid black; padding: 2px; margin-bottom: 5px;">Interface</div> MIL-STD-348B																			
<div style="border: 1px solid black; padding: 2px; margin-bottom: 5px;">Electrical Data</div> <table style="width: 100%; border-collapse: collapse;"> <tr> <td style="width: 60%;">Impedance</td> <td style="text-align: right;">50Ω</td> </tr> <tr> <td>Frequency range</td> <td style="text-align: right;">DC to 11GHz</td> </tr> <tr> <td>VSWR</td> <td style="text-align: right;">≤ 1.2 (DC to 11GHz)</td> </tr> <tr> <td>Insertion loss</td> <td style="text-align: right;">≤ 0.03 x √f(GHz) dB</td> </tr> <tr> <td>Insulation resistance</td> <td style="text-align: right;">≥ 5000MΩ</td> </tr> <tr> <td>Contact resistance inner conductor</td> <td style="text-align: right;">≤ 2mΩ</td> </tr> <tr> <td>Contact resistance outer conductor</td> <td style="text-align: right;">≤ 2mΩ</td> </tr> <tr> <td>Dielectric withstanding voltage (at sea level)</td> <td style="text-align: right;">1500 V rms</td> </tr> <tr> <td>Working voltage (at sea level)</td> <td style="text-align: right;">1000 V rms</td> </tr> </table>		Impedance	50Ω	Frequency range	DC to 11GHz	VSWR	≤ 1.2 (DC to 11GHz)	Insertion loss	≤ 0.03 x √f(GHz) dB	Insulation resistance	≥ 5000MΩ	Contact resistance inner conductor	≤ 2mΩ	Contact resistance outer conductor	≤ 2mΩ	Dielectric withstanding voltage (at sea level)	1500 V rms	Working voltage (at sea level)	1000 V rms
Impedance	50Ω																		
Frequency range	DC to 11GHz																		
VSWR	≤ 1.2 (DC to 11GHz)																		
Insertion loss	≤ 0.03 x √f(GHz) dB																		
Insulation resistance	≥ 5000MΩ																		
Contact resistance inner conductor	≤ 2mΩ																		
Contact resistance outer conductor	≤ 2mΩ																		
Dielectric withstanding voltage (at sea level)	1500 V rms																		
Working voltage (at sea level)	1000 V rms																		
<div style="border: 1px solid black; padding: 2px; margin-bottom: 5px;">Mechanical Data</div> <table style="width: 100%; border-collapse: collapse;"> <tr> <td style="width: 60%;">Engagement force</td> <td style="text-align: right;">≤ 3 lbs</td> </tr> <tr> <td>Disengagement force</td> <td style="text-align: right;">≤ 1.5 lbs</td> </tr> <tr> <td>Contact captivation-axial</td> <td style="text-align: right;">≤ 6.1 lbs</td> </tr> <tr> <td>Durability (mating)</td> <td style="text-align: right;">≥ 1000</td> </tr> </table>		Engagement force	≤ 3 lbs	Disengagement force	≤ 1.5 lbs	Contact captivation-axial	≤ 6.1 lbs	Durability (mating)	≥ 1000										
Engagement force	≤ 3 lbs																		
Disengagement force	≤ 1.5 lbs																		
Contact captivation-axial	≤ 6.1 lbs																		
Durability (mating)	≥ 1000																		
<div style="border: 1px solid black; padding: 2px; margin-bottom: 5px;">Environmental Data</div> <table style="width: 100%; border-collapse: collapse;"> <tr> <td style="width: 60%;">Temperature range</td> <td style="text-align: right;">-40°C to+165°C</td> </tr> <tr> <td>Thermal shock</td> <td style="text-align: right;">MIL-STD-202, Method 107, Condition B</td> </tr> <tr> <td>Moisture resistance</td> <td style="text-align: right;">MIL-STD-202, Method 106</td> </tr> <tr> <td>Corrosion</td> <td style="text-align: right;">MIL-STD-202, Method 101, Condition B</td> </tr> <tr> <td>RoHS</td> <td style="text-align: right;">Compliant</td> </tr> </table>		Temperature range	-40°C to+165°C	Thermal shock	MIL-STD-202, Method 107, Condition B	Moisture resistance	MIL-STD-202, Method 106	Corrosion	MIL-STD-202, Method 101, Condition B	RoHS	Compliant								
Temperature range	-40°C to+165°C																		
Thermal shock	MIL-STD-202, Method 107, Condition B																		
Moisture resistance	MIL-STD-202, Method 106																		
Corrosion	MIL-STD-202, Method 101, Condition B																		
RoHS	Compliant																		
<div style="border: 1px solid black; padding: 2px; margin-bottom: 5px;">Tooling</div> <table style="width: 100%; border-collapse: collapse;"> <tr> <td style="width: 60%;">Locator tool</td> <td style="text-align: right;">ST-011</td> </tr> <tr> <td>Soldering fixture</td> <td style="text-align: right;">ST-008</td> </tr> <tr> <td>Insert for .141 semi-rigid cable</td> <td style="text-align: right;">ST-010</td> </tr> </table>		Locator tool	ST-011	Soldering fixture	ST-008	Insert for .141 semi-rigid cable	ST-010												
Locator tool	ST-011																		
Soldering fixture	ST-008																		
Insert for .141 semi-rigid cable	ST-010																		

Notice: JYEBAO reserves the right to make modifications deemed appropriate.

JYE BAO CO., LTD.

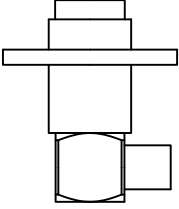
CABLE ASSEMBLY RECOMMENDATION

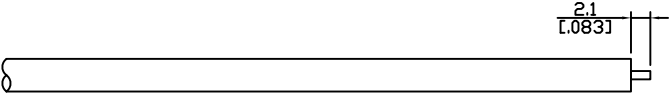
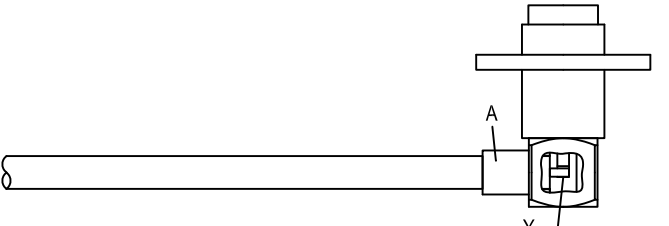
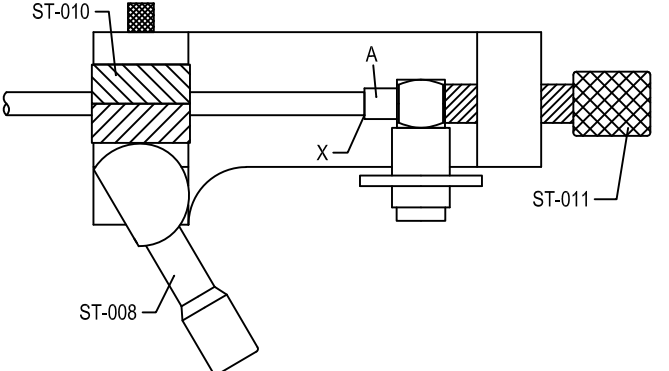
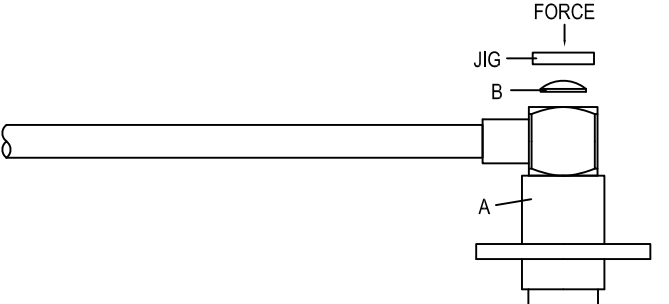
BMA8362-9141/W	DATE	2020/06/30	REV	—
<p>A</p>  <p>BODY</p>	<p>B</p>  <p>COVER</p>			
DIAGRAM	ASSEMBLY INSTRUCTION			
	Step 1: STRIP AS SHOWN.			
	Step 2: SLIDE CENTER CONDUCTOR ON THE CONTACT PIN OF CONNECTOR " A " AND SOLDER IN " Y ".			
	Step 3: USE SOLDERING FIXTURE " ST-008 ", INSERT TOOL " ST-010 " AND LOCATOR TOOL " ST-011 " TO FIX THE CONNECTOR. SOLDER IN " X ".			
	Step 4: PRESS ON THE TOP OF " B " WITH JIGS.			
<p>This part number complies with RoHS. Notice: JYEBAO reserves the right to make modifications deemed appropriate.</p>				
APPROVED	CHECKED	DRAWING	<i>Albert</i>	

BMA8362-9141/W

