

BMA8326A-0141/W

**BMA Jack Solder 2-Hole Flange For RG402
18GHz VSWR 1.2**

50Ω

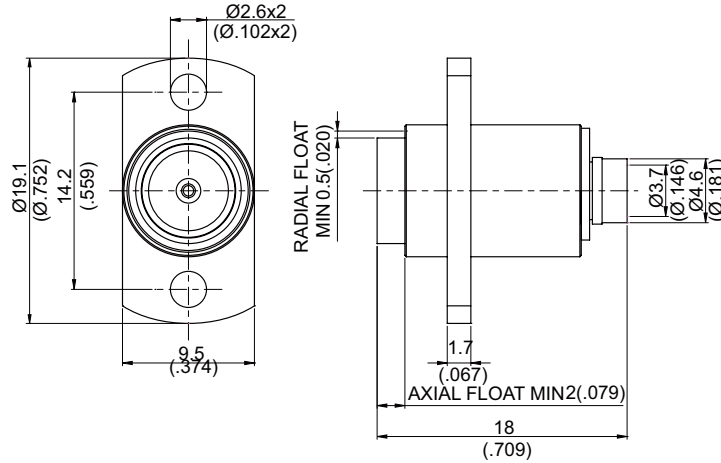

MOUNTING HOLES

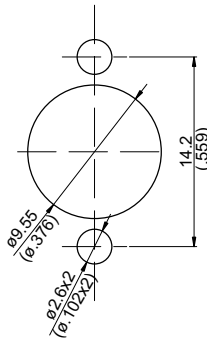

Parts	Material	Plating (Micro-inch)
E-Ring	Stainless Steel	Passivated
Contact Pin	Beryllium Copper	Gold 4 Over Nickel-Phosphorus 80 Over Copper 20
Insulator	Teflon	
Contact Body	Brass	Gold 4 Over Nickel-Phosphorus 80 Over Copper 20
Spring Washer	Beryllium Copper	Gold 4 Over Nickel-Phosphorus 80 Over Copper 20
Spring Ring	Beryllium Copper	Gold 4 Over Nickel-Phosphorus 80 Over Copper 20
Flange Body	Brass	Tin-Zinc-Copper-Alloy 100 Over Copper 50
Solder Body	Brass	Tin-Zinc-Copper-Alloy 100 Over Copper 50

Weight: 5.9 g

Suitable Cables: Semi-rigid.141

This part number complies with RoHS.

Notice: JYEBAO reserves the right to make modifications deemed appropriate.

BMA	BMA8326A-0141/W																		
<div style="border: 1px solid black; padding: 2px; margin-bottom: 5px;">Interface</div> MIL-STD-348B																			
<div style="border: 1px solid black; padding: 2px; margin-bottom: 5px;">Electrical Data</div> <table style="width: 100%; border-collapse: collapse;"> <tr> <td style="width: 60%;">Impedance</td> <td style="text-align: right;">50Ω</td> </tr> <tr> <td>Frequency range</td> <td style="text-align: right;">DC to 18GHz</td> </tr> <tr> <td>VSWR</td> <td style="text-align: right;">≤ 1.2 (DC to 18GHz)</td> </tr> <tr> <td>Insertion loss</td> <td style="text-align: right;">≤ 0.03 x √f(GHz) dB</td> </tr> <tr> <td>Insulation resistance</td> <td style="text-align: right;">≥ 5000MΩ</td> </tr> <tr> <td>Contact resistance inner conductor</td> <td style="text-align: right;">≤ 2mΩ</td> </tr> <tr> <td>Contact resistance outer conductor</td> <td style="text-align: right;">≤ 2mΩ</td> </tr> <tr> <td>Dielectric withstanding voltage (at sea level)</td> <td style="text-align: right;">1500 V rms</td> </tr> <tr> <td>Working voltage (at sea level)</td> <td style="text-align: right;">1000 V rms</td> </tr> </table>		Impedance	50Ω	Frequency range	DC to 18GHz	VSWR	≤ 1.2 (DC to 18GHz)	Insertion loss	≤ 0.03 x √f(GHz) dB	Insulation resistance	≥ 5000MΩ	Contact resistance inner conductor	≤ 2mΩ	Contact resistance outer conductor	≤ 2mΩ	Dielectric withstanding voltage (at sea level)	1500 V rms	Working voltage (at sea level)	1000 V rms
Impedance	50Ω																		
Frequency range	DC to 18GHz																		
VSWR	≤ 1.2 (DC to 18GHz)																		
Insertion loss	≤ 0.03 x √f(GHz) dB																		
Insulation resistance	≥ 5000MΩ																		
Contact resistance inner conductor	≤ 2mΩ																		
Contact resistance outer conductor	≤ 2mΩ																		
Dielectric withstanding voltage (at sea level)	1500 V rms																		
Working voltage (at sea level)	1000 V rms																		
<div style="border: 1px solid black; padding: 2px; margin-bottom: 5px;">Mechanical Data</div> <table style="width: 100%; border-collapse: collapse;"> <tr> <td style="width: 60%;">Engagement force</td> <td style="text-align: right;">≤ 3 lbs</td> </tr> <tr> <td>Disengagement force</td> <td style="text-align: right;">≤ 1.5 lbs</td> </tr> <tr> <td>Contact captivation-axial</td> <td style="text-align: right;">≤ 6.1 lbs</td> </tr> <tr> <td>Durability (mating)</td> <td style="text-align: right;">≥ 1000</td> </tr> </table>		Engagement force	≤ 3 lbs	Disengagement force	≤ 1.5 lbs	Contact captivation-axial	≤ 6.1 lbs	Durability (mating)	≥ 1000										
Engagement force	≤ 3 lbs																		
Disengagement force	≤ 1.5 lbs																		
Contact captivation-axial	≤ 6.1 lbs																		
Durability (mating)	≥ 1000																		
<div style="border: 1px solid black; padding: 2px; margin-bottom: 5px;">Environmental Data</div> <table style="width: 100%; border-collapse: collapse;"> <tr> <td style="width: 60%;">Temperature range</td> <td style="text-align: right;">-65°C to+165°C</td> </tr> <tr> <td>Thermal shock</td> <td style="text-align: right;">MIL-STD-202, Method 107, Condition B</td> </tr> <tr> <td>Moisture resistance</td> <td style="text-align: right;">MIL-STD-202, Method 106</td> </tr> <tr> <td>Corrosion</td> <td style="text-align: right;">MIL-STD-202, Method 101, Condition B</td> </tr> <tr> <td>RoHS</td> <td style="text-align: right;">Compliant</td> </tr> </table>		Temperature range	-65°C to+165°C	Thermal shock	MIL-STD-202, Method 107, Condition B	Moisture resistance	MIL-STD-202, Method 106	Corrosion	MIL-STD-202, Method 101, Condition B	RoHS	Compliant								
Temperature range	-65°C to+165°C																		
Thermal shock	MIL-STD-202, Method 107, Condition B																		
Moisture resistance	MIL-STD-202, Method 106																		
Corrosion	MIL-STD-202, Method 101, Condition B																		
RoHS	Compliant																		
<div style="border: 1px solid black; padding: 2px; margin-bottom: 5px;">Tooling</div> <table style="width: 100%; border-collapse: collapse;"> <tr> <td style="width: 60%;">Locator tool</td> <td style="text-align: right;">ST-011 , ST-BMA83</td> </tr> <tr> <td>Soldering fixture</td> <td style="text-align: right;">ST-008</td> </tr> <tr> <td>Insert for .141 semi-rigid cable</td> <td style="text-align: right;">ST-010</td> </tr> </table>		Locator tool	ST-011 , ST-BMA83	Soldering fixture	ST-008	Insert for .141 semi-rigid cable	ST-010												
Locator tool	ST-011 , ST-BMA83																		
Soldering fixture	ST-008																		
Insert for .141 semi-rigid cable	ST-010																		

Notice: JYEBAO reserves the right to make modifications deemed appropriate.

JYE BAO CO., LTD.

CABLE ASSEMBLY INSTRUCTION

BMA8326A-0141/W	DATE	2020/02/18	REV	—
-----------------	------	------------	-----	---

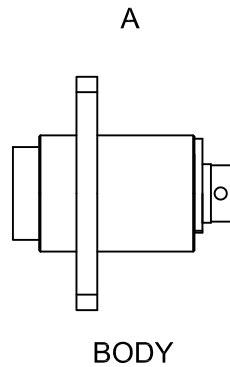
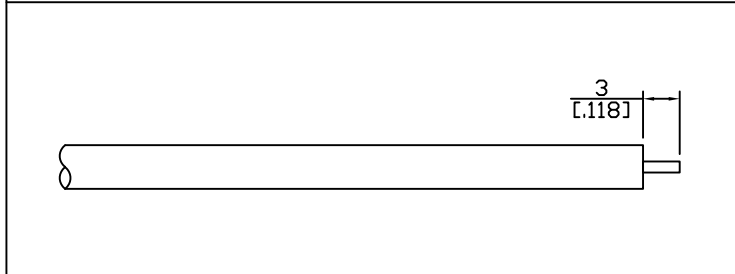
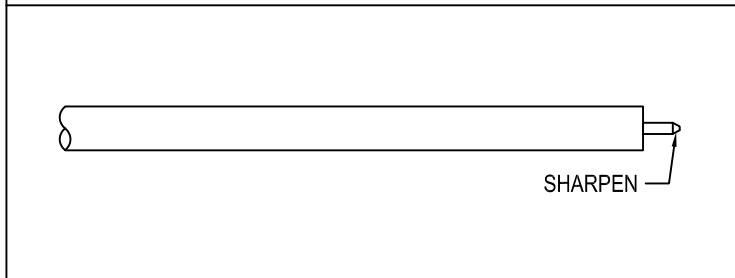

DIAGRAM	ASSEMBLY INSTRUCTION
---------	----------------------



Step 1: STRIP AS SHOWN.



Step 2: SHARPEN CENTER CONDUCTOR TIP.

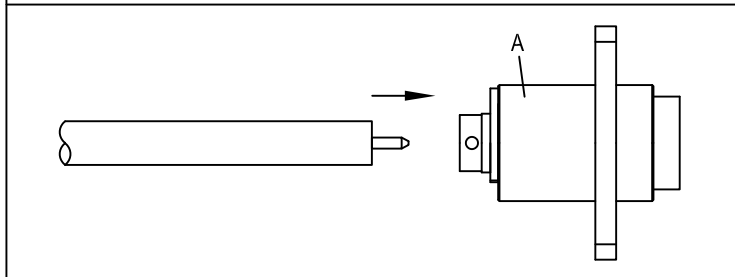

Step 3: SLIDE CABLE INTO CONNECTOR BODY "A".

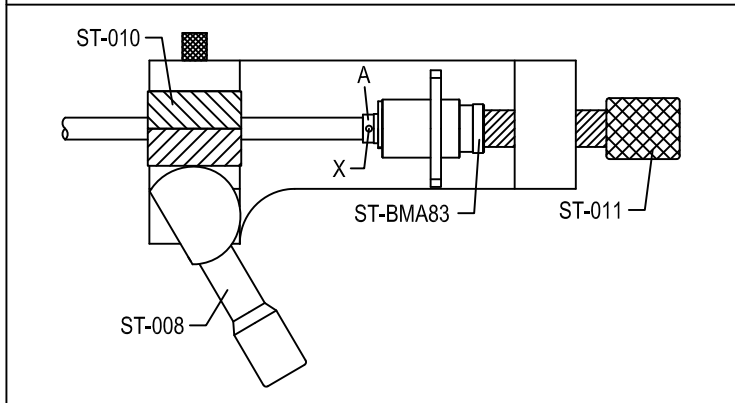

Step 4: USE SOLDERING FIXTURE " ST-008 ", INSERT TOOL " ST-010 " AND LOCATOR TOOL " ST-011 " AND " ST-BMA83 " TO FIX THE CONNECTOR. SOLDER IN " X ".

This part number complies with RoHS.

Notice: JYEBAO reserves the right to make modifications deemed appropriate.

APPROVED	CHECKED	DRAWING	<i>Albert</i>
----------	---------	---------	---------------