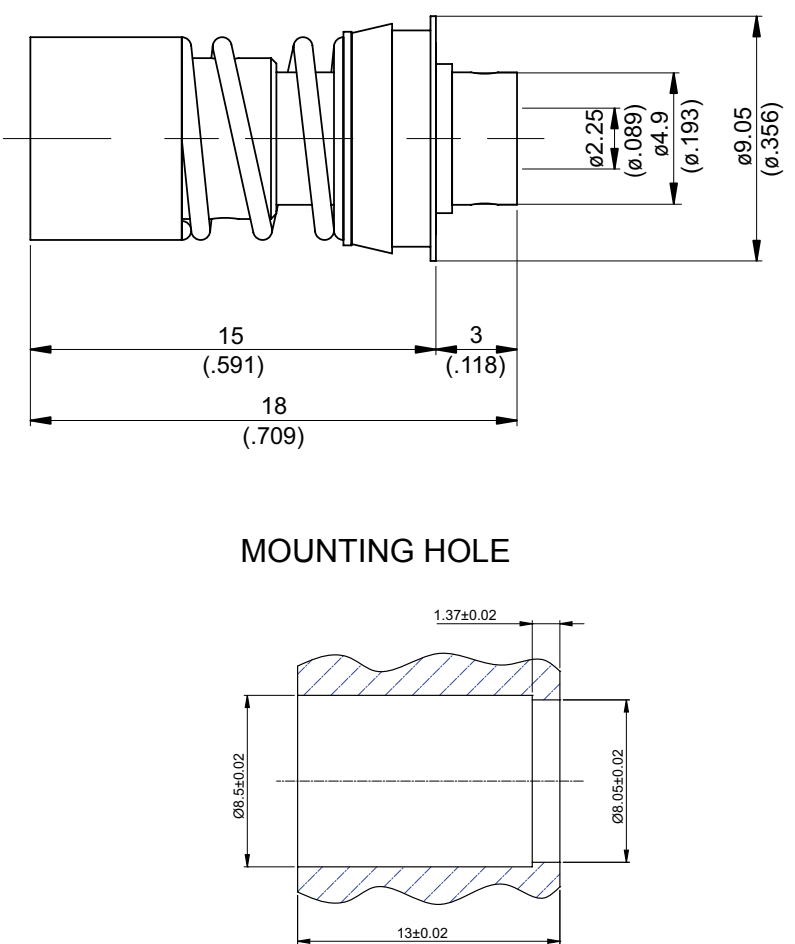

BMA8300Q-0085	BMA Jack Snap On Solder For RG405 18GHz VSWR1.2	50Ω																														
 <p style="text-align: center;"><b>MOUNTING HOLE</b></p>																																
<table border="1"> <thead> <tr> <th>Parts</th> <th>Material</th> <th>Plating (Micro-inch)</th> </tr> </thead> <tbody> <tr> <td>E-Ring</td> <td>Stainless Steel</td> <td>Passivated</td> </tr> <tr> <td>Retainer Ring</td> <td>Stainless Steel</td> <td>Passivated</td> </tr> <tr> <td>Spring</td> <td>Stainless Steel</td> <td>Passivated</td> </tr> <tr> <td>Contact Pin</td> <td>Beryllium Copper</td> <td>Gold 4 Over Nickel-Phosphorus Alloy 80 Over Copper 20</td> </tr> <tr> <td>Insulator</td> <td>Teflon</td> <td></td> </tr> <tr> <td>Contact Body</td> <td>Stainless Steel</td> <td>Gold 5 over Nickel 50 over Copper 50</td> </tr> <tr> <td>Spring Washer</td> <td>Beryllium Copper</td> <td>Gold 4 Over Nickel-Phosphorus Alloy 80 Over Copper 20</td> </tr> <tr> <td>Spring Ring</td> <td>Beryllium Copper</td> <td>Gold 4 Over Nickel-Phosphorus Alloy 80 Over Copper 20</td> </tr> <tr> <td>Body</td> <td>Stainless</td> <td>Gold 5 over Nickel 50 over Copper 50</td> </tr> </tbody> </table>	Parts	Material	Plating (Micro-inch)	E-Ring	Stainless Steel	Passivated	Retainer Ring	Stainless Steel	Passivated	Spring	Stainless Steel	Passivated	Contact Pin	Beryllium Copper	Gold 4 Over Nickel-Phosphorus Alloy 80 Over Copper 20	Insulator	Teflon		Contact Body	Stainless Steel	Gold 5 over Nickel 50 over Copper 50	Spring Washer	Beryllium Copper	Gold 4 Over Nickel-Phosphorus Alloy 80 Over Copper 20	Spring Ring	Beryllium Copper	Gold 4 Over Nickel-Phosphorus Alloy 80 Over Copper 20	Body	Stainless	Gold 5 over Nickel 50 over Copper 50		
Parts	Material	Plating (Micro-inch)																														
E-Ring	Stainless Steel	Passivated																														
Retainer Ring	Stainless Steel	Passivated																														
Spring	Stainless Steel	Passivated																														
Contact Pin	Beryllium Copper	Gold 4 Over Nickel-Phosphorus Alloy 80 Over Copper 20																														
Insulator	Teflon																															
Contact Body	Stainless Steel	Gold 5 over Nickel 50 over Copper 50																														
Spring Washer	Beryllium Copper	Gold 4 Over Nickel-Phosphorus Alloy 80 Over Copper 20																														
Spring Ring	Beryllium Copper	Gold 4 Over Nickel-Phosphorus Alloy 80 Over Copper 20																														
Body	Stainless	Gold 5 over Nickel 50 over Copper 50																														
<p>Weight: 3.06 g Suitable Cables: Semi-rigid.085</p>																																

This part number complies with RoHS.

Notice: JYEBAO reserves the right to make modifications deemed appropriate.

BMA	BMA8300Q-0085																		
<div data-bbox="167 344 568 389" style="border: 1px solid black; padding: 2px;">Interface</div> <p>MIL-STD-348B</p>																			
<div data-bbox="167 512 568 557" style="border: 1px solid black; padding: 2px;">Electrical Data</div> <table border="0" style="width: 100%;"> <tr> <td style="width: 50%;">Impedance</td> <td style="width: 50%;">50Ω</td> </tr> <tr> <td>Frequency range</td> <td>DC to 18GHz</td> </tr> <tr> <td>VSWR</td> <td>≦ 1.2 (DC to 18GHz)</td> </tr> <tr> <td>Insertion loss</td> <td>≦ 0.03 x √f(GHz) dB</td> </tr> <tr> <td>Insulation resistance</td> <td>≧ 5000MΩ</td> </tr> <tr> <td>Contact resistance inner conductor</td> <td>≦ 2mΩ</td> </tr> <tr> <td>Contact resistance outer conductor</td> <td>≦ 2mΩ</td> </tr> <tr> <td>Dielectric withstanding voltage (at sea level)</td> <td>1000 V rms</td> </tr> <tr> <td>Working voltage (at sea level)</td> <td>670 V rms</td> </tr> </table>		Impedance	50Ω	Frequency range	DC to 18GHz	VSWR	≦ 1.2 (DC to 18GHz)	Insertion loss	≦ 0.03 x √f(GHz) dB	Insulation resistance	≧ 5000MΩ	Contact resistance inner conductor	≦ 2mΩ	Contact resistance outer conductor	≦ 2mΩ	Dielectric withstanding voltage (at sea level)	1000 V rms	Working voltage (at sea level)	670 V rms
Impedance	50Ω																		
Frequency range	DC to 18GHz																		
VSWR	≦ 1.2 (DC to 18GHz)																		
Insertion loss	≦ 0.03 x √f(GHz) dB																		
Insulation resistance	≧ 5000MΩ																		
Contact resistance inner conductor	≦ 2mΩ																		
Contact resistance outer conductor	≦ 2mΩ																		
Dielectric withstanding voltage (at sea level)	1000 V rms																		
Working voltage (at sea level)	670 V rms																		
<div data-bbox="167 1057 568 1102" style="border: 1px solid black; padding: 2px;">Mechanical Data</div> <table border="0" style="width: 100%;"> <tr> <td style="width: 50%;">Engagement force</td> <td style="width: 50%;">≧ 3 lbs</td> </tr> <tr> <td>Disengagement force</td> <td>≧ 1.5 lbs</td> </tr> <tr> <td>Contact captivation-axial</td> <td>≧ 6.1 lbs</td> </tr> <tr> <td>Durability (mating)</td> <td>≧ 1000</td> </tr> </table>		Engagement force	≧ 3 lbs	Disengagement force	≧ 1.5 lbs	Contact captivation-axial	≧ 6.1 lbs	Durability (mating)	≧ 1000										
Engagement force	≧ 3 lbs																		
Disengagement force	≧ 1.5 lbs																		
Contact captivation-axial	≧ 6.1 lbs																		
Durability (mating)	≧ 1000																		
<div data-bbox="167 1364 568 1408" style="border: 1px solid black; padding: 2px;">Environmental Data</div> <table border="0" style="width: 100%;"> <tr> <td style="width: 50%;">Temperature range</td> <td style="width: 50%;">-65°C to+165°C</td> </tr> <tr> <td>Thermal shock</td> <td>MIL-STD-202, Method 107, Condition B</td> </tr> <tr> <td>Moisture resistance</td> <td>MIL-STD-202, Method 106</td> </tr> <tr> <td>Corrosion</td> <td>MIL-STD-202, Method 101, Condition B</td> </tr> <tr> <td>RoHS</td> <td>Compliant</td> </tr> </table>		Temperature range	-65°C to+165°C	Thermal shock	MIL-STD-202, Method 107, Condition B	Moisture resistance	MIL-STD-202, Method 106	Corrosion	MIL-STD-202, Method 101, Condition B	RoHS	Compliant								
Temperature range	-65°C to+165°C																		
Thermal shock	MIL-STD-202, Method 107, Condition B																		
Moisture resistance	MIL-STD-202, Method 106																		
Corrosion	MIL-STD-202, Method 101, Condition B																		
RoHS	Compliant																		
<div data-bbox="167 1718 568 1762" style="border: 1px solid black; padding: 2px;">Tooling</div> <table border="0" style="width: 100%;"> <tr> <td style="width: 50%;">Locator tool</td> <td style="width: 50%;">ST-011, ST-BMA83</td> </tr> <tr> <td>Soldering fixture</td> <td>ST-008</td> </tr> <tr> <td>Insert for .085 semi-rigid cable</td> <td>ST-009</td> </tr> </table>		Locator tool	ST-011, ST-BMA83	Soldering fixture	ST-008	Insert for .085 semi-rigid cable	ST-009												
Locator tool	ST-011, ST-BMA83																		
Soldering fixture	ST-008																		
Insert for .085 semi-rigid cable	ST-009																		

Notice: JYEBAO reserves the right to make modifications deemed appropriate.

# JYE BAO CO., LTD.

## CABLE ASSEMBLY INSTRUCTION

BMA8300Q-0085	DATE	2021/02/23	REV	A
---------------	------	------------	-----	---

A

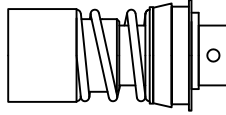

BODY

DIAGRAM	ASSEMBLY INSTRUCTION
---------	----------------------

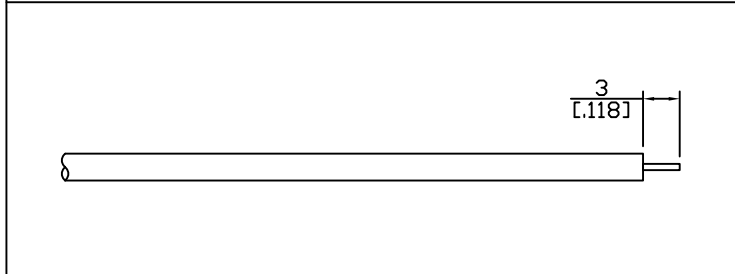

Step 1: STRIP AS SHOWN.

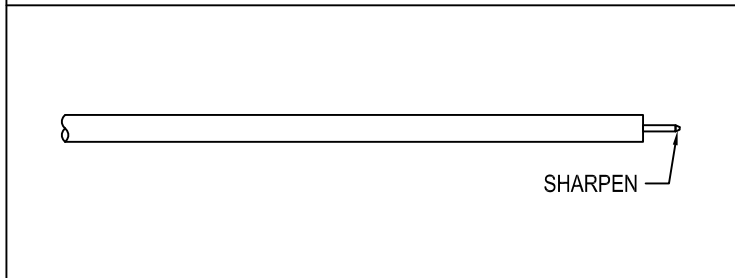

Step 2: SHARPEN CENTER CONDUCTOR TIP.

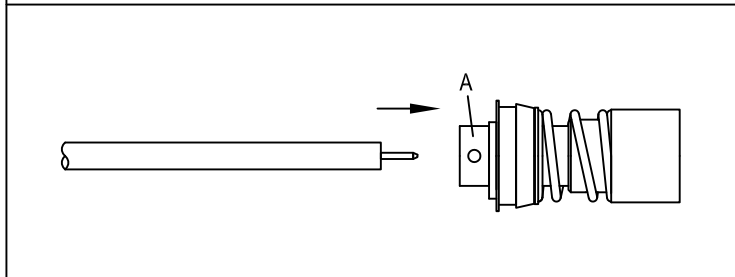

Step 3: SLIDE CABLE INTO CONNECTOR BODY "A".

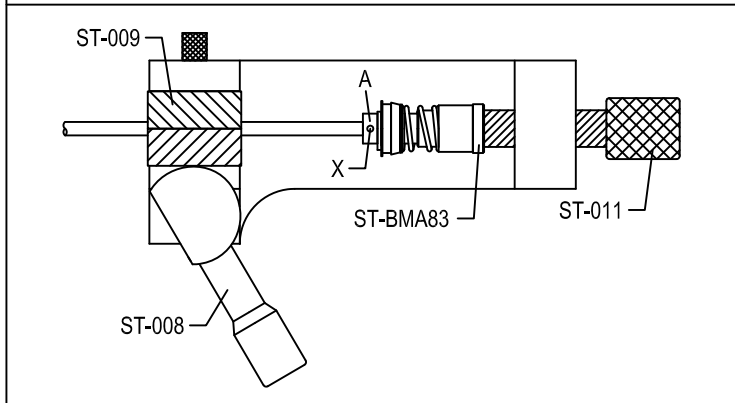

Step 4: USE SOLDERING FIXTURE " ST-008 ", INSERT TOOL " ST-009 " AND LOCATOR TOOL " ST-011 " AND " ST-BMA83 " TO FIX THE CONNECTOR. SOLDER IN " X ".

This part number complies with RoHS.

Notice: JYEBAO reserves the right to make modifications deemed appropriate.

APPROVED	CHECKED	DRAWING	<i>Albert</i>
----------	---------	---------	---------------

# BMA8300Q-0085

