

ALS-PC3PC8-1.15	Mitered 3.5mm Plug To 3.5mm Jack 34.5GHz VSWR 1.15	50Ω
-----------------	---	-----

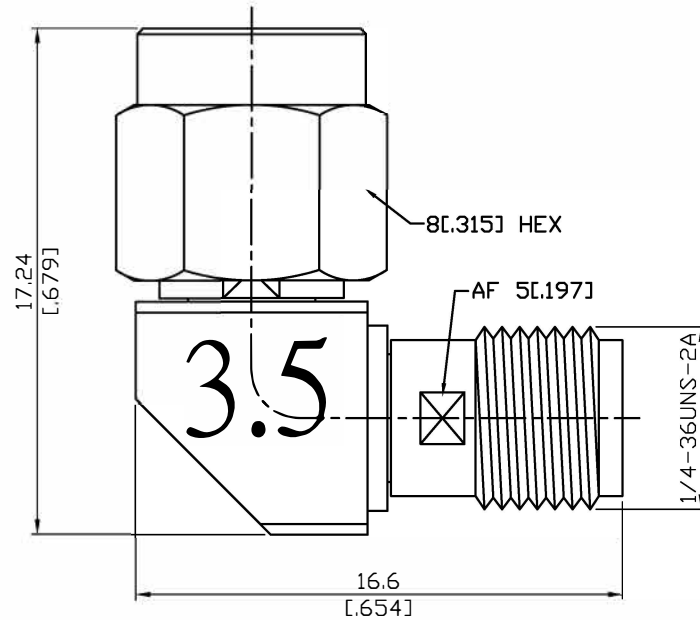

Parts	Material	Plating (Micro-inch)
Insulator	PPO	
Gasket	Silicone	
Centre Contact	Beryllium Copper	Gold 4 Over Nickel-Phosphorus Alloy 80 Over Copper 20
Retainer Ring	Beryllium Copper	Tin-Zinc-Copper-Alloy 100 Over Copper 50
Body	Stainless Steel	Passivated
Coupling Nut	Stainless Steel	Passivated

--	--

This part number complies with RoHS.

Notice: JYEBAO reserves the right to make modifications deemed appropriate.

ALS-PC3PC8-1.15	Mitered 3.5mm Plug To 3.5mm Jack 34.5GHz VSWR 1.15																		
<table border="0"> <tr> <td colspan="2" data-bbox="129 342 531 394">Interface</td> </tr> <tr> <td data-bbox="129 400 794 434">Standard</td> <td data-bbox="794 400 1481 434">IEC60169-23</td> </tr> <tr> <td data-bbox="129 448 794 481">Mechanically compatible with</td> <td data-bbox="794 448 1481 481">2.92 & SMA</td> </tr> </table>		Interface		Standard	IEC60169-23	Mechanically compatible with	2.92 & SMA												
Interface																			
Standard	IEC60169-23																		
Mechanically compatible with	2.92 & SMA																		
<table border="0"> <tr> <td colspan="2" data-bbox="129 602 531 654">Electrical Data</td> </tr> <tr> <td data-bbox="129 660 794 694">Impedance</td> <td data-bbox="794 660 1481 694">50Ω</td> </tr> <tr> <td data-bbox="129 707 794 741">Frequency Range</td> <td data-bbox="794 707 1481 741">DC to 34.5GHz</td> </tr> <tr> <td data-bbox="129 754 794 788">VSWR</td> <td data-bbox="794 754 1481 788">≤ 1.15 (DC To 34.5GHz)</td> </tr> <tr> <td data-bbox="129 801 794 835">Insertion Loss</td> <td data-bbox="794 801 1481 835">≤ 0.06 x √f(GHz) dB</td> </tr> <tr> <td data-bbox="129 848 794 882">Insulation Resistance</td> <td data-bbox="794 848 1481 882">≥ 5000MΩ</td> </tr> <tr> <td data-bbox="129 896 794 929">Dielectric Withstanding Voltage (at sea level)</td> <td data-bbox="794 896 1481 929">1000 V rms</td> </tr> <tr> <td data-bbox="129 943 794 976">Working Voltage (at sea level)</td> <td data-bbox="794 943 1481 976">335 V rms</td> </tr> <tr> <td data-bbox="129 990 794 1023">RF Leakage</td> <td data-bbox="794 990 1481 1023">≥ 100dB to 1GHz</td> </tr> </table>		Electrical Data		Impedance	50Ω	Frequency Range	DC to 34.5GHz	VSWR	≤ 1.15 (DC To 34.5GHz)	Insertion Loss	≤ 0.06 x √f(GHz) dB	Insulation Resistance	≥ 5000MΩ	Dielectric Withstanding Voltage (at sea level)	1000 V rms	Working Voltage (at sea level)	335 V rms	RF Leakage	≥ 100dB to 1GHz
Electrical Data																			
Impedance	50Ω																		
Frequency Range	DC to 34.5GHz																		
VSWR	≤ 1.15 (DC To 34.5GHz)																		
Insertion Loss	≤ 0.06 x √f(GHz) dB																		
Insulation Resistance	≥ 5000MΩ																		
Dielectric Withstanding Voltage (at sea level)	1000 V rms																		
Working Voltage (at sea level)	335 V rms																		
RF Leakage	≥ 100dB to 1GHz																		
<table border="0"> <tr> <td colspan="2" data-bbox="129 1151 531 1202">Mechanical Data</td> </tr> <tr> <td data-bbox="129 1209 794 1243">Recommended Coupling Nut Torque</td> <td data-bbox="794 1209 1481 1243">7.1 to 9.7 in-lbs</td> </tr> <tr> <td data-bbox="129 1256 794 1290">Coupling Proof Torque</td> <td data-bbox="794 1256 1481 1290">15 in-lbs</td> </tr> <tr> <td data-bbox="129 1303 794 1337">Coupling Nut Retention Force</td> <td data-bbox="794 1303 1481 1337">≥ 60.7 lbs</td> </tr> <tr> <td data-bbox="129 1350 794 1384">Contact Captivation-axial</td> <td data-bbox="794 1350 1481 1384">≥ 6.1 lbs</td> </tr> <tr> <td data-bbox="129 1397 794 1431">Durability (mating)</td> <td data-bbox="794 1397 1481 1431">≥ 500</td> </tr> </table>		Mechanical Data		Recommended Coupling Nut Torque	7.1 to 9.7 in-lbs	Coupling Proof Torque	15 in-lbs	Coupling Nut Retention Force	≥ 60.7 lbs	Contact Captivation-axial	≥ 6.1 lbs	Durability (mating)	≥ 500						
Mechanical Data																			
Recommended Coupling Nut Torque	7.1 to 9.7 in-lbs																		
Coupling Proof Torque	15 in-lbs																		
Coupling Nut Retention Force	≥ 60.7 lbs																		
Contact Captivation-axial	≥ 6.1 lbs																		
Durability (mating)	≥ 500																		
<table border="0"> <tr> <td colspan="2" data-bbox="129 1554 531 1606">Environmental Data</td> </tr> <tr> <td data-bbox="129 1612 794 1646">Temperature Range</td> <td data-bbox="794 1612 1481 1646">-55°C to +105°C</td> </tr> <tr> <td data-bbox="129 1659 794 1693">Thermal Shock</td> <td data-bbox="794 1659 1481 1693">MIL-STD-202, Method 107, Condition B</td> </tr> <tr> <td data-bbox="129 1706 794 1740">Moisture Resistance</td> <td data-bbox="794 1706 1481 1740">MIL-STD-202, Method 206</td> </tr> <tr> <td data-bbox="129 1753 794 1787">Corrosion</td> <td data-bbox="794 1753 1481 1787">MIL-STD-202, Method 101, Condition B</td> </tr> <tr> <td data-bbox="129 1800 794 1834">RoHS</td> <td data-bbox="794 1800 1481 1834">Compliant</td> </tr> </table>		Environmental Data		Temperature Range	-55°C to +105°C	Thermal Shock	MIL-STD-202, Method 107, Condition B	Moisture Resistance	MIL-STD-202, Method 206	Corrosion	MIL-STD-202, Method 101, Condition B	RoHS	Compliant						
Environmental Data																			
Temperature Range	-55°C to +105°C																		
Thermal Shock	MIL-STD-202, Method 107, Condition B																		
Moisture Resistance	MIL-STD-202, Method 206																		
Corrosion	MIL-STD-202, Method 101, Condition B																		
RoHS	Compliant																		

Notice: JYEBAO reserves the right to make modifications deemed appropriate.

ALS-PC3PC8-1.15

