

ALS-A8N3-18-1.2

Mitered SMA Jack To N Plug  
18GHz VSWR 1.2

50Ω

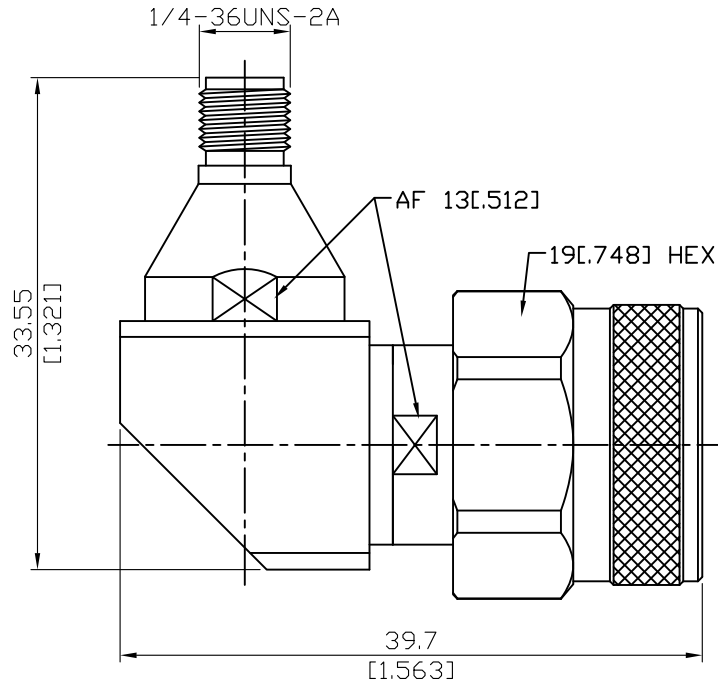

Parts	Material	Plating ( Micro-inch )
Retainer Ring	Brass	Tin-Zinc-Copper-Alloy 100 Over Copper 50
Gasket	Silicone	
Contact Pin	Beryllium Copper	Gold 4 Over Nickel-Phosphorus Alloy 80 Over Copper 20
Insulator	Teflon	
Body	Stainless Steel	Passivated
Coupling Nut	Stainless Steel	Passivated

This part number complies with RoHS.

Notice: JYEBAO reserves the right to make modifications deemed appropriate.

ALS-A8N3-18-1.2	Mitered SMA Jack To N Plug 18GHz VSWR 1.2													
<b>Interface</b> Standard Mechanically compatible with	<table border="1"> <thead> <tr> <th>SMA</th> <th>N</th> </tr> </thead> <tbody> <tr> <td>MIL-STD-348B</td> <td>MIL-STD-348B</td> </tr> <tr> <td>2.92 &amp; 3.5</td> <td></td> </tr> </tbody> </table>	SMA	N	MIL-STD-348B	MIL-STD-348B	2.92 & 3.5								
SMA	N													
MIL-STD-348B	MIL-STD-348B													
2.92 & 3.5														
<b>Electrical Data</b> Impedance Frequency Range VSWR Insertion Loss Insulation Resistance Dielectric Withstanding Voltage (at sea level) Working Voltage (at sea level)	<table> <tbody> <tr> <td>50Ω</td> </tr> <tr> <td>DC To 18GHz</td> </tr> <tr> <td>≤ 1.2 (DC To 18GHz)</td> </tr> <tr> <td>≤ 0.07 x √f(GHz) dB</td> </tr> <tr> <td>≥ 5000MΩ</td> </tr> <tr> <td>1500 V rms</td> </tr> <tr> <td>500 V rms</td> </tr> </tbody> </table>		50Ω	DC To 18GHz	≤ 1.2 (DC To 18GHz)	≤ 0.07 x √f(GHz) dB	≥ 5000MΩ	1500 V rms	500 V rms					
50Ω														
DC To 18GHz														
≤ 1.2 (DC To 18GHz)														
≤ 0.07 x √f(GHz) dB														
≥ 5000MΩ														
1500 V rms														
500 V rms														
<b>Mechanical Data</b> Recommended Coupling Nut Torque Coupling Proof Torque Coupling Nut Retention Force Contact Captivation-axial Durability (mating)	<table border="1"> <thead> <tr> <th>SMA</th> <th>N</th> </tr> </thead> <tbody> <tr> <td>7 to 9.5 in-lbs</td> <td>6 to 10 in-lbs</td> </tr> <tr> <td>15 in-lbs</td> <td>15 in-lbs</td> </tr> <tr> <td>NA</td> <td>≥ 101.2 lbs</td> </tr> <tr> <td>≥ 6.1 lbs</td> <td>≥ 6.3 lbs</td> </tr> <tr> <td>≥ 500</td> <td>≥ 500</td> </tr> </tbody> </table>		SMA	N	7 to 9.5 in-lbs	6 to 10 in-lbs	15 in-lbs	15 in-lbs	NA	≥ 101.2 lbs	≥ 6.1 lbs	≥ 6.3 lbs	≥ 500	≥ 500
SMA	N													
7 to 9.5 in-lbs	6 to 10 in-lbs													
15 in-lbs	15 in-lbs													
NA	≥ 101.2 lbs													
≥ 6.1 lbs	≥ 6.3 lbs													
≥ 500	≥ 500													
<b>Environmental Data</b> Temperature Range Thermal Shock Moisture Resistance Corrosion RoHS	<table> <tbody> <tr> <td>-65°C to +165°C</td> </tr> <tr> <td>MIL-STD-202, Method 107, Condition B</td> </tr> <tr> <td>MIL-STD-202, Method 206</td> </tr> <tr> <td>MIL-STD-202, Method 101, Condition B</td> </tr> <tr> <td>Compliant</td> </tr> </tbody> </table>		-65°C to +165°C	MIL-STD-202, Method 107, Condition B	MIL-STD-202, Method 206	MIL-STD-202, Method 101, Condition B	Compliant							
-65°C to +165°C														
MIL-STD-202, Method 107, Condition B														
MIL-STD-202, Method 206														
MIL-STD-202, Method 101, Condition B														
Compliant														

Notice: JYEBAO reserves the right to make modifications deemed appropriate.

# ALS-A8N3-18-1.2

