

ALS-A3T8-18-1.2

Mitered SMA Plug To TNC Jack
18GHz VSWR 1.2

50Ω

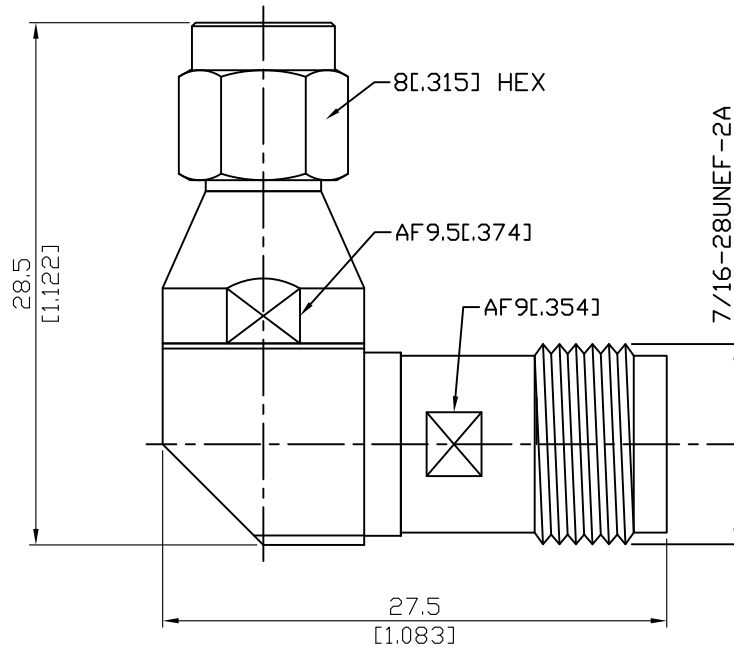

Parts	Material	Plating (Micro-inch)
Retainer Ring	Beryllium Copper	Tin-Zinc-Copper-Alloy 100 Over Copper 50
Gasket	Silicone	
Ring	Stainless Steel	Passivated
Contact Pin	Beryllium Copper	Gold 4 Over Nickel-Phosphorus Alloy 80 Over Copper 20
Insulator	Teflon	
Body	Stainless Steel	Passivated
Coupling Nut	Stainless Steel	Passivated

This part number complies with RoHS.

Notice: JYEBAO reserves the right to make modifications deemed appropriate.

ALS-A3T8-18-1.2	Mitered SMA Plug To TNC Jack 18GHz VSWR 1.2															
<div style="border: 1px solid black; padding: 2px; margin-bottom: 5px;">Interface</div> Standard Mechanically compatible with	<table border="1" style="width: 100%; border-collapse: collapse;"> <thead> <tr> <th style="width: 50%;">SMA</th> <th style="width: 50%;">TNC</th> </tr> </thead> <tbody> <tr> <td>MIL-STD-348B</td> <td>MIL-STD-348B</td> </tr> <tr> <td>2.92 & 3.5</td> <td></td> </tr> </tbody> </table>	SMA	TNC	MIL-STD-348B	MIL-STD-348B	2.92 & 3.5										
SMA	TNC															
MIL-STD-348B	MIL-STD-348B															
2.92 & 3.5																
<div style="border: 1px solid black; padding: 2px; margin-bottom: 5px;">Electrical Data</div> Impedance Frequency Range VSWR Insertion Loss Insulation Resistance Dielectric Withstanding Voltage (at sea level) Working Voltage (at sea level)	<table style="width: 100%;"> <tbody> <tr> <td style="width: 50%;">50Ω</td> <td style="width: 50%;"></td> </tr> <tr> <td>DC To 18GHz</td> <td></td> </tr> <tr> <td>≤ 1.2 (DC To 18GHz)</td> <td></td> </tr> <tr> <td>≤ 0.07 x √f(GHz) dB</td> <td></td> </tr> <tr> <td>≥ 5000MΩ</td> <td></td> </tr> <tr> <td>1500 V rms</td> <td></td> </tr> <tr> <td>500 V rms</td> <td></td> </tr> </tbody> </table>		50Ω		DC To 18GHz		≤ 1.2 (DC To 18GHz)		≤ 0.07 x √f(GHz) dB		≥ 5000MΩ		1500 V rms		500 V rms	
50Ω																
DC To 18GHz																
≤ 1.2 (DC To 18GHz)																
≤ 0.07 x √f(GHz) dB																
≥ 5000MΩ																
1500 V rms																
500 V rms																
<div style="border: 1px solid black; padding: 2px; margin-bottom: 5px;">Mechanical Data</div> Recommended Coupling Nut Torque Coupling Proof Torque Coupling Nut Retention Force Contact Captivation-axial Durability (mating)	<table border="1" style="width: 100%; border-collapse: collapse;"> <thead> <tr> <th style="width: 50%;">SMA</th> <th style="width: 50%;">TNC</th> </tr> </thead> <tbody> <tr> <td>7 to 9.5 in-lbs</td> <td>4.1 to 6.1 in-lbs</td> </tr> <tr> <td>15 in-lbs</td> <td>15 in-lbs</td> </tr> <tr> <td>≥ 60.7 lbs</td> <td>NA</td> </tr> <tr> <td>≥ 6.1 lbs</td> <td>≥ 6.1 lbs</td> </tr> <tr> <td>≥ 500</td> <td>≥ 500</td> </tr> </tbody> </table>	SMA	TNC	7 to 9.5 in-lbs	4.1 to 6.1 in-lbs	15 in-lbs	15 in-lbs	≥ 60.7 lbs	NA	≥ 6.1 lbs	≥ 6.1 lbs	≥ 500	≥ 500			
SMA	TNC															
7 to 9.5 in-lbs	4.1 to 6.1 in-lbs															
15 in-lbs	15 in-lbs															
≥ 60.7 lbs	NA															
≥ 6.1 lbs	≥ 6.1 lbs															
≥ 500	≥ 500															
<div style="border: 1px solid black; padding: 2px; margin-bottom: 5px;">Environmental Data</div> Temperature Range Thermal Shock Moisture Resistance Corrosion RoHS	<table style="width: 100%;"> <tbody> <tr> <td style="width: 50%;">-65°C to +165°C</td> <td style="width: 50%;"></td> </tr> <tr> <td>MIL-STD-202, Method</td> <td></td> </tr> <tr> <td>MIL-STD-202, Method</td> <td></td> </tr> <tr> <td>MIL-STD-202, Method</td> <td></td> </tr> <tr> <td>Compliant</td> <td></td> </tr> </tbody> </table>		-65°C to +165°C		MIL-STD-202, Method		MIL-STD-202, Method		MIL-STD-202, Method		Compliant					
-65°C to +165°C																
MIL-STD-202, Method																
MIL-STD-202, Method																
MIL-STD-202, Method																
Compliant																

Notice: JYEBAO reserves the right to make modifications deemed appropriate.

ALS-A3T8-18-1.2

