

ALS-A3T3-18-1.2

Mitered SMA Plug To TNC Plug  
18GHz VSWR 1.2

50Ω

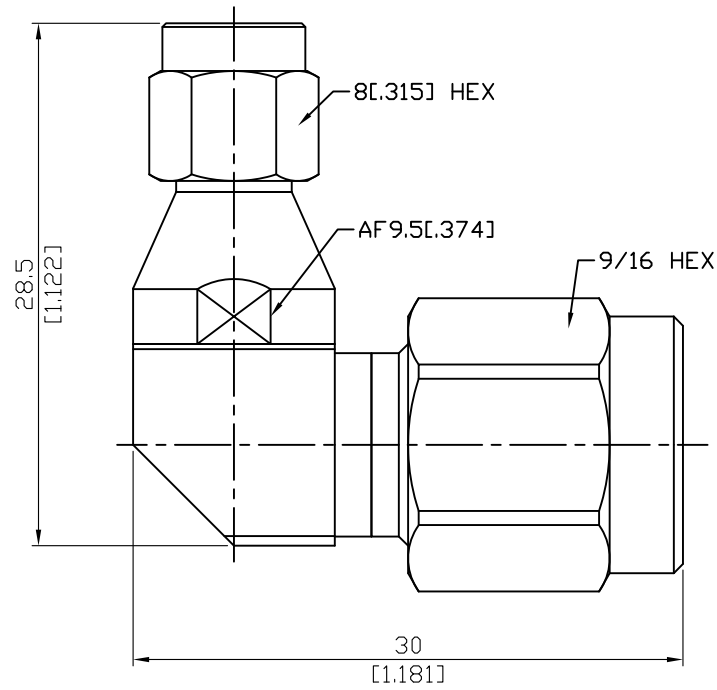

Parts	Material	Plating ( Micro-inch )
Retainer Ring	P.Bronze	Tin-Zinc-Copper-Alloy 100 Over Copper 50
Retainer Ring	Beryllium Copper	Tin-Zinc-Copper-Alloy 100 Over Copper 50
Gasket	Silicone	
Contact Pin	Beryllium Copper	Gold 4 Over Nickel-Phosphorus Alloy 80 Over Copper 20
Insulator	Teflon	
Body	Stainless Steel	Passivated
Coupling Nut	Stainless Steel	Passivated

This part number complies with RoHS.

Notice: JYEBAO reserves the right to make modifications deemed appropriate.

ALS-A3T3-18-1.2		Mitered SMA Plug To TNC Plug 18GHz VSWR 1.2	
<b>Interface</b>		SMA	TNC
Standard		MIL-STD-348B	MIL-STD-348B
Mechanically compatible with		2.92 & 3.5	
<b>Electrical Data</b>			
Impedance		50Ω	
Frequency Range		DC To 18GHz	
VSWR		≤ 1.2 (DC To 18GHz)	
Insertion Loss		≤ 0.07 x √f(GHz) dB	
Insulation Resistance		≥ 5000MΩ	
Dielectric Withstanding Voltage (at sea level)		1500 V rms	
Working Voltage (at sea level)		500 V rms	
<b>Mechanical Data</b>		SMA	TNC
Recommended Coupling Nut Torque		7 to 9.5 in-lbs	4.1 to 6.1 in-lbs
Coupling Proof Torque		15 in-lbs	15 in-lbs
Coupling Nut Retention Force		≥ 60.7 lbs	≥ 101.2 lbs
Contact Captivation-axial		≥ 6.1 lbs	≥ 6.1 lbs
Durability (mating)		≥ 500	≥ 500
<b>Environmental Data</b>			
Temperature Range		-65°C to +165°C	
Thermal Shock		MIL-STD-202, Method	
Moisture Resistance		MIL-STD-202, Method	
Corrosion		MIL-STD-202, Method	
RoHS		Compliant	

Notice: JYEBAO reserves the right to make modifications deemed appropriate.

# ALS-A3T3-18-1.2

