

ALS-A3N8-18-1.3

Mitered SMA Plug To N Jack  
18GHz VSWR 1.3

50Ω

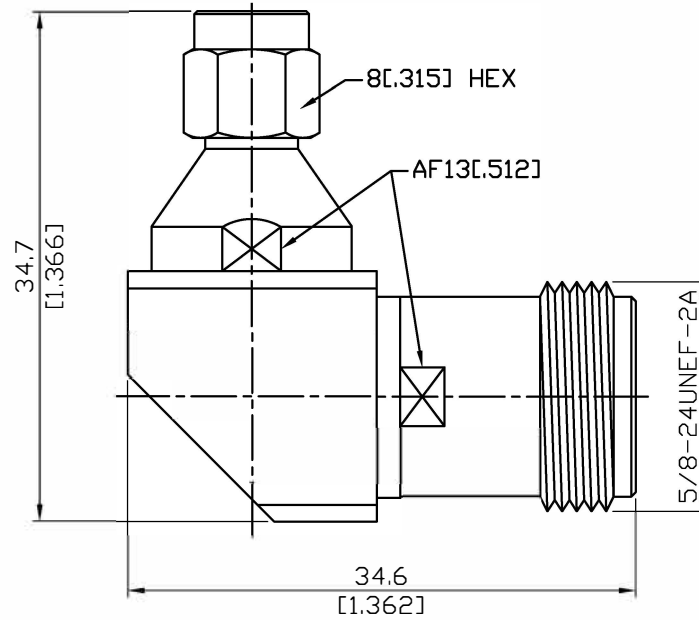

Parts	Material	Plating ( Micro-inch )
Retainer Ring	Beryllium Copper	Tin-Zinc-Copper-Alloy 100 Over Copper 50
Gasket	Silicone	
Contact Pin	Beryllium Copper	Gold 4 Over Nickel-Phosphorus Alloy 80 Over Copper 20
Insulator	Teflon	
Body	Stainless Steel	Passivated
Coupling Nut	Stainless Steel	Passivated

This part number complies with RoHS.

Notice: JYEBAO reserves the right to make modifications deemed appropriate.

ALS-A3N8-18-1.3	Mitered SMA Plug To N Jack 18GHz VSWR 1.3	
<b>Interface</b> Standard Mechanically compatible with	SMA MIL-STD-348B 2.92 & 3.5	N MIL-STD-348B
<b>Electrical Data</b> Impedance Frequency Range VSWR Insertion Loss Insulation Resistance Dielectric Withstanding Voltage (at sea level) Working Voltage (at sea level)	50Ω DC To 18GHz $\leq 1.3$ (DC To 18GHz) $\leq 0.07 \times \sqrt{f(\text{GHz})}$ dB $\geq 5000\text{M}\Omega$ 1500 V rms 500 V rms	
<b>Mechanical Data</b> Recommended Coupling Nut Torque Coupling Proof Torque Coupling Nut Retention Force Contact Captivation-axial Durability (mating)	SMA 7 to 9.5 in-lbs 15 in-lbs $\geq 60.7$ lbs $\geq 6.1$ lbs $\geq 500$	N 6 to 10 in-lbs 15 in-lbs NA $\geq 6.3$ lbs $\geq 500$
<b>Environmental Data</b> Temperature Range Thermal Shock Moisture Resistance Corrosion RoHS	-65°C to +165°C MIL-STD-202, Method 107, Condition B MIL-STD-202, Method 206 MIL-STD-202, Method 101, Condition B Compliant	

Notice: JYEBAO reserves the right to make modifications deemed appropriate.

# ALS-A3N8-18-1.3

