

AL-N3N3

N plug to N plug right angle  
11GHz VSWR 1.2

50Ω

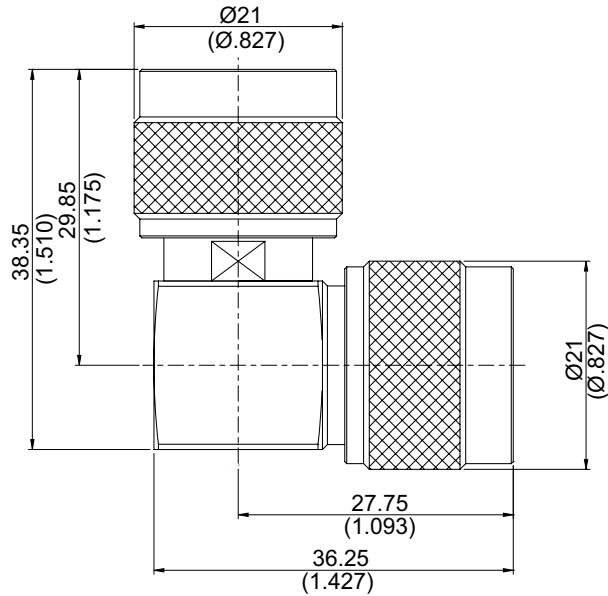

Parts	Material	Plating (Micro-inch)
Cover	Brass	Tin-Zinc-Copper-Alloy 100 Over Copper 50
Nut	Brass	Tin-Zinc-Copper-Alloy 100 Over Copper 50
Contact Pin	Brass	Gold 4 Over Nickel Phosphorous Alloy 80 Over Copper 20
Contact Body	Brass	Tin-Zinc-Copper-Alloy 100 Over Copper 50
Insulator	Teflon	
Retainer Ring	Brass	Tin-Zinc-Copper-Alloy 100 Over Copper 50
Gasket	Silicon	
Body	Brass	Tin-Zinc-Copper-Alloy 100 Over Copper 50
Coupling Nut	Brass	Tin-Zinc-Copper-Alloy 100 Over Copper 50

Weight:

This part number complies with RoHS.

Notice: JYBAO reserves the right to make modifications deemed appropriate.

AL-N3N3	N Plug to N Plug Right Angle 11GHz VSWR 1.2																
<table border="0"> <tr> <td data-bbox="113 322 531 394"><b>Interface</b></td> <td data-bbox="531 322 1482 394"></td> </tr> <tr> <td data-bbox="113 394 531 539">Standard</td> <td data-bbox="531 394 1482 539">MIL-STD-348B</td> </tr> </table>		<b>Interface</b>		Standard	MIL-STD-348B												
<b>Interface</b>																	
Standard	MIL-STD-348B																
<table border="0"> <tr> <td data-bbox="113 539 531 611"><b>Electrical Data</b></td> <td data-bbox="531 539 1482 611"></td> </tr> <tr> <td data-bbox="113 611 531 656">Impedance</td> <td data-bbox="531 611 1482 656">50Ω</td> </tr> <tr> <td data-bbox="113 656 531 701">Frequency Range</td> <td data-bbox="531 656 1482 701">DC to 11GHz</td> </tr> <tr> <td data-bbox="113 701 531 745">VSWR</td> <td data-bbox="531 701 1482 745">≤ 1.2 (DC To 11GHz)</td> </tr> <tr> <td data-bbox="113 745 531 790">Insertion Loss</td> <td data-bbox="531 745 1482 790">≤ 0.07 x √f(GHz) dB</td> </tr> <tr> <td data-bbox="113 790 531 835">Insulation Resistance</td> <td data-bbox="531 790 1482 835">≥ 5000MΩ</td> </tr> <tr> <td data-bbox="113 835 531 880">Dielectric Withstanding Voltage (at sea level)</td> <td data-bbox="531 835 1482 880">2500 V rms</td> </tr> <tr> <td data-bbox="113 880 531 925">Working Voltage (at sea level)</td> <td data-bbox="531 880 1482 925">1000 V rms</td> </tr> </table>		<b>Electrical Data</b>		Impedance	50Ω	Frequency Range	DC to 11GHz	VSWR	≤ 1.2 (DC To 11GHz)	Insertion Loss	≤ 0.07 x √f(GHz) dB	Insulation Resistance	≥ 5000MΩ	Dielectric Withstanding Voltage (at sea level)	2500 V rms	Working Voltage (at sea level)	1000 V rms
<b>Electrical Data</b>																	
Impedance	50Ω																
Frequency Range	DC to 11GHz																
VSWR	≤ 1.2 (DC To 11GHz)																
Insertion Loss	≤ 0.07 x √f(GHz) dB																
Insulation Resistance	≥ 5000MΩ																
Dielectric Withstanding Voltage (at sea level)	2500 V rms																
Working Voltage (at sea level)	1000 V rms																
<table border="0"> <tr> <td data-bbox="113 1037 531 1108"><b>Mechanical Data</b></td> <td data-bbox="531 1037 1482 1108"></td> </tr> <tr> <td data-bbox="113 1108 531 1153">Recommended Coupling Nut Torque</td> <td data-bbox="531 1108 1482 1153">6 to 10 in-lbs</td> </tr> <tr> <td data-bbox="113 1153 531 1198">Coupling Proof Torque</td> <td data-bbox="531 1153 1482 1198">15 in-lbs</td> </tr> <tr> <td data-bbox="113 1198 531 1243">Coupling Nut Retention Force</td> <td data-bbox="531 1198 1482 1243">≥ 101.2 lbs</td> </tr> <tr> <td data-bbox="113 1243 531 1288">Contact Captivation-axial</td> <td data-bbox="531 1243 1482 1288">≥ 6.3 lbs</td> </tr> <tr> <td data-bbox="113 1288 531 1332">Durability (mating)</td> <td data-bbox="531 1288 1482 1332">≥ 500</td> </tr> </table>		<b>Mechanical Data</b>		Recommended Coupling Nut Torque	6 to 10 in-lbs	Coupling Proof Torque	15 in-lbs	Coupling Nut Retention Force	≥ 101.2 lbs	Contact Captivation-axial	≥ 6.3 lbs	Durability (mating)	≥ 500				
<b>Mechanical Data</b>																	
Recommended Coupling Nut Torque	6 to 10 in-lbs																
Coupling Proof Torque	15 in-lbs																
Coupling Nut Retention Force	≥ 101.2 lbs																
Contact Captivation-axial	≥ 6.3 lbs																
Durability (mating)	≥ 500																
<table border="0"> <tr> <td data-bbox="113 1435 531 1507"><b>Environmental Data</b></td> <td data-bbox="531 1435 1482 1507"></td> </tr> <tr> <td data-bbox="113 1507 531 1552">Temperature Range</td> <td data-bbox="531 1507 1482 1552">-65°C to +165°C</td> </tr> <tr> <td data-bbox="113 1552 531 1597">Thermal Shock</td> <td data-bbox="531 1552 1482 1597">MIL-STD-202, Method 107, Condition B</td> </tr> <tr> <td data-bbox="113 1597 531 1641">Moisture Resistance</td> <td data-bbox="531 1597 1482 1641">MIL-STD-202, Method 206</td> </tr> <tr> <td data-bbox="113 1641 531 1686">Corrosion</td> <td data-bbox="531 1641 1482 1686">MIL-STD-202, Method 101, Condition B</td> </tr> <tr> <td data-bbox="113 1686 531 1731">RoHS</td> <td data-bbox="531 1686 1482 1731">Compliant</td> </tr> </table>		<b>Environmental Data</b>		Temperature Range	-65°C to +165°C	Thermal Shock	MIL-STD-202, Method 107, Condition B	Moisture Resistance	MIL-STD-202, Method 206	Corrosion	MIL-STD-202, Method 101, Condition B	RoHS	Compliant				
<b>Environmental Data</b>																	
Temperature Range	-65°C to +165°C																
Thermal Shock	MIL-STD-202, Method 107, Condition B																
Moisture Resistance	MIL-STD-202, Method 206																
Corrosion	MIL-STD-202, Method 101, Condition B																
RoHS	Compliant																

Notice: JYEBAO reserves the right to make modifications deemed appropriate.