

AL-A3N8	SMA Plug To N Jack Right Angle 8GHz VSWR 1.2	50Ω
---------	---	------------

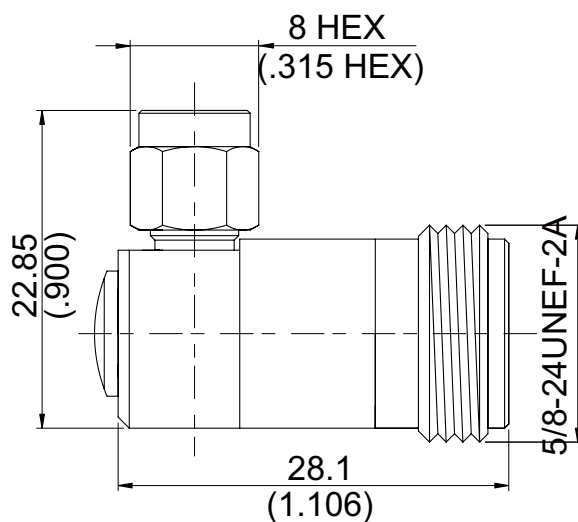

Parts	Material	Plating (Micro-inch)
Cover	Brass	Tin-Zinc-Copper-Alloy 100 Over Copper 50
Body(SMA)	Brass	Gold 4 Over Nickel-Phosphorus Alloy 80 Over Copper 20
Body(N)	Brass	Tin-Zinc-Copper-Alloy 100 Over Copper 50
Contact Pin(N)	P.Bronze	Gold 4 Over Nickel-Phosphorus Alloy 80 Over Copper 20
Contact Pin(SMA)	Brass	Gold 4 Over Nickel-Phosphorus Alloy 80 Over Copper 20
Retainer Ring	Beryllium Copper	Tin-Zinc-Copper-Alloy 100 Over Copper 50
Gasket	Silicone	
Insulator	Teflon	
Coupling Nut	Brass	Gold 4 Over Nickel-Phosphorus Alloy 80 Over Copper 20

Weight: 54.23 g

This part number complies with RoHS.

Notice: JYEBAO reserves the right to make modifications deemed appropriate.

AL-A3N8		SMA Plug To N Jack Right Angle 8GHz VSWR 1.2	
Interface		SMA	N
Standard		MIL-STD-348B	MIL-STD-348B
Mechanically compatible with		2.92 & 3.5	
Electrical Data			
Impedance		50Ω	
Frequency Range		DC To 8GHz	
VSWR		≤ 1.2 (DC To 8GHz)	
Insertion Loss		≤ 0.07 x √f(GHz) dB	
Insulation Resistance		≥ 5000MΩ	
Dielectric Withstanding Voltage (at sea level)		1500 V rms	
Working Voltage (at sea level)		500 V rms	
Mechanical Data			
		SMA	N
Recommended Coupling Nut Torque		4 in-lbs	6 to 10 in-lbs
Coupling Proof Torque		5.3 in-lbs	15 in-lbs
Coupling Nut Retention Force		≥ 60.7 lbs	NA
Contact Captivation-axial		≥ 6.1 lbs	≥ 6.3 lbs
Durability (mating)		≥ 100	≥ 500
Environmental Data			
Temperature Range		-65°C to +165°C	
Thermal Shock		MIL-STD-202, Method 107, Condition B	
Moisture Resistance		MIL-STD-202, Method 206	
Corrosion		MIL-STD-202, Method 101, Condition B	
RoHS		Compliant	

Notice: JYEBAO reserves the right to make modifications deemed appropriate.