

AL-A3A8

SMA Plug To SMA Jack Right Angle
10GHz VSWR 1.2

50Ω

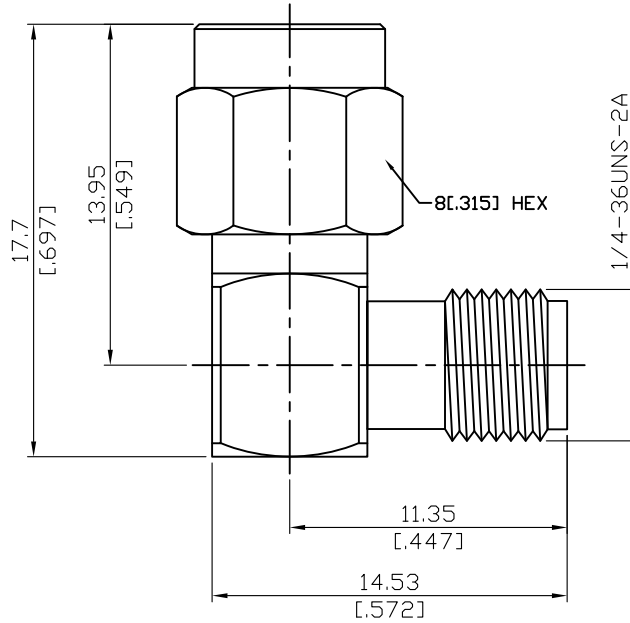

Parts	Material	Plating (Micro-inch)
Cover	Brass	Gold 4 Over Nickel-Phosphorus Alloy 80 Over Copper 20
Retainer Ring	Beryllium Copper	Tin-Zinc-Copper-Alloy 100 Over Copper 50
Gasket	Silicone	
Contact Pin	Beryllium Copper	Gold 4 Over Nickel-Phosphorus Alloy 80 Over Copper 20
Insulator	Teflon	
Body	Brass	Gold 4 Over Nickel-Phosphorus Alloy 80 Over Copper 20
Coupling Nut	Brass	Gold 4 Over Nickel-Phosphorus Alloy 80 Over Copper 20

Weight: 3.26g

This part number complies with RoHS.

Notice: JYEBAO reserves the right to make modifications deemed appropriate.

AL-A3A8	SMA Plug To SMA Jack Right Angle 10GHz VSWR 1.2
<div data-bbox="129 342 531 394" style="border: 1px solid black; padding: 2px;">Interface</div> <p data-bbox="129 405 1011 488">Standard MIL-STD-348B Mechanically compatible with 2.92 & 3.5</p>	
<div data-bbox="129 602 531 654" style="border: 1px solid black; padding: 2px;">Electrical Data</div> <p data-bbox="129 663 1107 981">Impedance 50Ω Frequency Range DC To 10GHz VSWR ≤ 1.2 (DC To 10GHz) Insertion Loss ≤ 0.06 x √f(GHz) dB Insulation Resistance ≥ 5000MΩ Dielectric Withstanding Voltage (at sea level) 1500 V rms Working Voltage (at sea level) 500 V rms</p>	
<div data-bbox="129 1102 531 1153" style="border: 1px solid black; padding: 2px;">Mechanical Data</div> <p data-bbox="129 1162 943 1384">Recommended Coupling Nut Torque 4 in-lbs Coupling Proof Torque 5.3 in-lbs Coupling Nut Retention Force ≥ 60.7 lbs Contact Captivation-axial ≥ 6.1 lbs Durability (mating) ≥ 100</p>	
<div data-bbox="129 1503 531 1554" style="border: 1px solid black; padding: 2px;">Environmental Data</div> <p data-bbox="129 1563 1366 1785">Temperature Range -65°C to +165°C Thermal Shock MIL-STD-202, Method 107, Condition B Moisture Resistance MIL-STD-202, Method 206 Corrosion MIL-STD-202, Method 101, Condition B RoHS Compliant</p>	

AL-A3A8

